

Mathematics Grade 9

By:
Siyavula Uploaders

Mathematics Grade 9

By:

Siyavula Uploaders

Online:

< <http://cnx.org/content/col11056/1.1/> >

C O N N E X I O N S

Rice University, Houston, Texas

This selection and arrangement of content as a collection is copyrighted by Siyavula Uploaders. It is licensed under the Creative Commons Attribution 3.0 license (<http://creativecommons.org/licenses/by/3.0/>).

Collection structure revised: September 14, 2009

PDF generated: February 6, 2011

For copyright and attribution information for the modules contained in this collection, see p. 208.

Table of Contents

1 Term 1	
1.1	Numbers - where do they come from? 1
1.2	Easier algebra with exponents 12
1.3	Why all the fuss about Pythagoras? 19
1.4	How long is a piece of string? 28
1.5	Money Matters 34
2 Term 2	
2.1	The algebra of the four basic operations 41
2.2	Geometry of lines and triangles 53
2.3	Space and shape 64
2.4	Congruency 72
2.5	Similarity 83
2.6	Worksheets 92
3 Term 3	
3.1	Number patterns 101
3.2	Understanding what graphs tell us 112
3.3	Understanding how equations are represented on a graph 123
3.4	Finding the equation of a straight line graph from a diagram 134
3.5	Solving simple problems by forming and solving equations 139
3.6	Collecting information to answer general questions 147
3.7	Analyse data for meaningful patterns and measures 153
3.8	Extract meaningful information from data 162
3.9	Understanding the context and vocabulary of probability 173
4 Term 4	
4.1	Explore and identify the characteristics of some quadrilaterals 181
4.2	Compare quadrilaterals for similarities and differences 187
4.3	Understanding quadrilaterals and their properties in problems 193
4.4	Drawing plan and side views of three-dimensional objects to scale 196
4.5	Understand and use the principle of translation, learning suitable notations 200
Attributions 208

Chapter 1

Term 1

1.1 Numbers - where do they come from?¹

1.1.1 MATHEMATICS

1.1.2 Grade 9

1.1.3 NUMBERS

1.1.4 Module 1

1.1.5 NUMBERS – WHERE DO THEY COME FROM?

Numbers – where do they come from?

CLASS WORK

1 Our name for the set of Natural numbers is \mathbb{N} , and we write it: $\mathbb{N} = \{ 1 ; 2 ; 3 ; . . . \}$

1.1 Will the answer always be a natural number if you add any two natural numbers? How will you convince someone that it is always the case?

1.2 Multiply any two natural numbers. Is the answer always also a natural number?

1.3 Now subtract any natural number from any other natural number. Describe all the sorts of answers you can expect. Try to write down why this happens.

2 To deal with the answers you got in 1.3, we have to extend the number system to include zero and negative numbers – we call them, with the natural numbers, the integers. They are called \mathbb{Z} and this is one way to write them down: $\mathbb{Z} = \{ 0 ; \pm 1 ; \pm 2 ; \pm 3 ; . . . \}$

2.1 Complete the following definitions by writing down what has to be inside the brackets:

- Counting numbers $\mathbb{N}_0 = \{ \dots \}$
- Integers $\mathbb{Z} = \{ \dots \}$ in another way! (*Integers are also called whole numbers*)

3 Is the answer always another integer when you divide any integer by any other integer (except zero)? To allow for these answers we have to extend the number system to the rational numbers:

3.1 \mathbb{Q} (rational numbers) is the set of all the numbers which can be written in the form $\frac{a}{b}$ where a and b are integers as long as b is not zero. Explain very clearly why b is not allowed to be zero.

4 \mathbb{Q}' (irrational numbers) is the set of numbers which cannot be written as a common fraction, and are therefore not in \mathbb{Q} . Putting \mathbb{Q} en \mathbb{Q}' together gives the set called \mathbb{R} , the real numbers.

4.1 Write down what you think is in the set \mathbb{R}' . They are called non-real numbers.

end of CLASS WORK

¹This content is available online at <http://cnx.org/content/m31203/1.1/>.

Quipu is an Inca word meaning a string (or set of strings) with knots in it. This system was used for remembering things, mainly numbers. It was used widely in the ancient world; not only in South America. At its simplest, it was just one string with each knot representing one item. In more advanced systems, more strings were used, often of different colours; sometimes a system of place-values was used.

HOMEWORK ASSIGNMENT

1. What is the importance of having a symbol for zero? Think about all the things we'll be unable to do if we didn't have a zero.

2 Find out what we call the set of numbers we get when putting \mathbb{R} and \mathbb{R}' together. Can you say more about them?

3 Design your own set of number symbols like those in table 1. Show how any number can be written in your system. Now think up new symbols for $+$ and $-$ and \times and $[\text{U+FOB8}]$, and then make up a few sums to show how your system works.

end of HOMEWORK ASSIGNMENT

ENRICHMENT ASSIGNMENT

Let's check out the rational numbers

- Do the following sums on your own calculator to confirm that they are correct:
- Remember to do the operations in the proper order.

$$1. \quad 2 + 3 [\text{U+FOB8}] \quad 100 + 1 + 1 [\text{U+FOB8}] \quad 10 = 3,013$$

Is 3,013 a rational number? Yes! Look at this bit of magic:

$$3,013 = \frac{3}{1} + \frac{13}{1000} = \frac{3000}{1000} + \frac{13}{1000} = \frac{3000+13}{1000} = \frac{3013}{1000}$$

It is easy to write it down straightaway. Explain the method carefully.

$$2 \quad 3 + 2 \div 3 - 1 + 1 \div \underline{3} = 2,333 \dots = 2, \dot{3} \quad \text{Another rational number:}$$

$$\text{Let } x = 2,333 \dots \therefore 10x = 23,333 \dots \text{ Subtract: } 9x = 21 \therefore x = \frac{21}{9}$$

$$3 \quad 6 + 9 \div 22 - 2 + 3 \div \underline{11} = 4,1363636 \dots = 4,1\dot{3}\dot{6}$$

Is $4,1\dot{3}\dot{6}$ a rational number? Yes – do this:

$$\text{Let } x = 4,1363636 \dots \quad \therefore 10x = 41,3636 \dots \text{ and } \therefore 1000x = 4136,3636 \dots$$

$$\text{Subtract the last two:} \quad 1000x - 10x = 4136,3636 \dots - 41,3636 \dots$$

$$\therefore 990x = 4095 \quad \text{Solve:} \quad x = \frac{4095}{990} = \frac{91}{22}$$

Pretty easy.

Figure 1.1

4 Only *terminating* and *repeating* decimal fractions can be written in the form $\frac{a}{b}$.

4.1 Here are some irrational numbers (check them out on your calculator):

$$[\text{U+F010}] \quad \sqrt{2} \sqrt[3]{11} \quad 3,030030003000030 \dots$$

4.2 These are NOT irrational – explain why not: $\frac{22}{7}$; $\sqrt{25}$; $\sqrt[3]{27}$

4.3 Write the following numbers in the form $\frac{a}{b}$:

4.3.1 1,553

4.3.2 $0,5\dot{6}$

4.3.3 $30,341\dot{3}4\dot{1}$

4.3.4 $2,427\dot{2}7\dot{2}$

Figure 1.2

end of ENRICHMENT ASSIGNMENT

Working accurately

CLASS ASSIGNMENT

1 With every question, simplify the numbers, if necessary, and then place each number in its best position on the given number line.

1.1 6; 2; 4; 1; $5+2$; $9-1$; 3,0; 0,00; 5,0000

0 8

1.2 2; 5; -3; -4; $3-3$; -1

-5 5

Figure 1.3

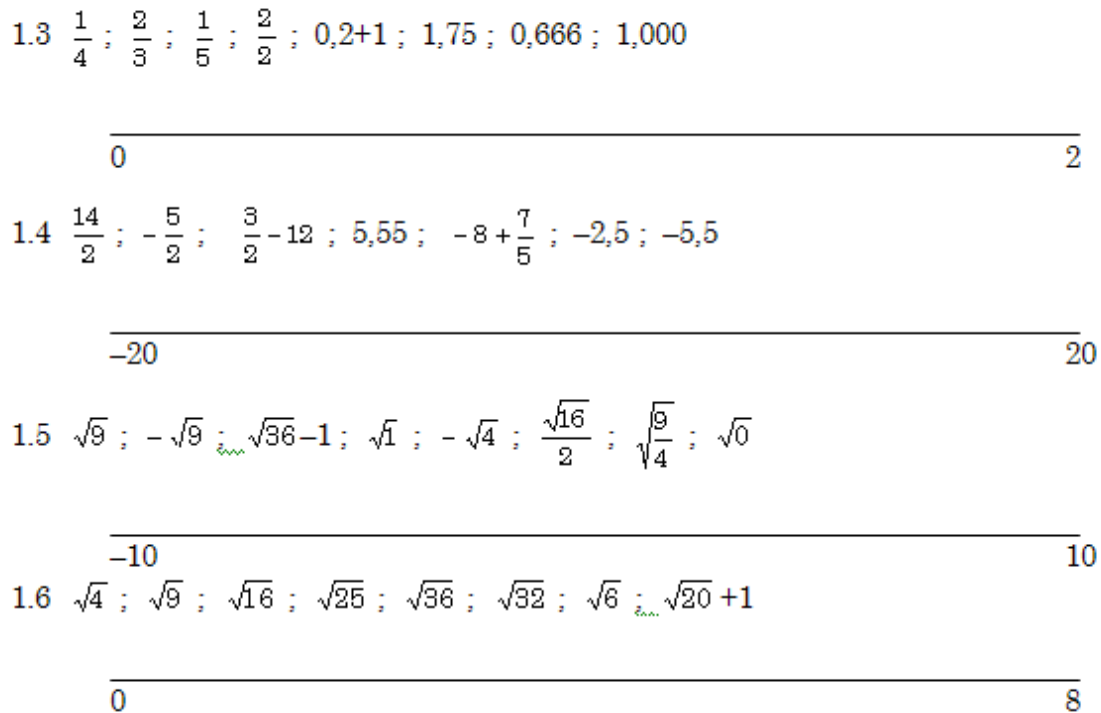

Figure 1.4

end of CLASS ASSIGNMENT
ENRICHMENT ASSIGNMENT

Inequalities – translating words into maths

1 The number line tells us something very important: If a number lies to the *left* of another number, it must be the smaller one. A number to the *right* of another is the bigger.

For example (keep the number line in mind) 4,5 is to the left of 10, so 4,5 must be smaller than 10. Mathematically: $4,5 < 10$.

- -3 is to the left of 5, so -3 is smaller than 5. Mathematically speaking: $-3 < 5$
- 6 is to the right of 0, so 6 is bigger than 0 and we write: $6 > 0$ or $0 < 6$, because 0 is smaller than 6.

What about numbers that are equal to each other? Surely 6 [U+FOB8] 3 and $\sqrt{4}$!

So: 6 [U+FOB8] $3 = \sqrt{4}$.

1.1 Use $<$ or $>$ or $=$ between the numbers in the following pairs, without swopping the numbers around: 5,6 and 5,7; $3+9$ and 4×3 ; -1 and -2; 3 and -3 $\sqrt[3]{27}$ and $\sqrt{15}$

2 We use the same signs when working with variables (like x and y, etc.). .

For example, if we want to mention all the numbers larger than 3, then we use an x to stand for *all* those numbers (of course there are infinitely many of them: 3,1 and 3,2 and 3,34 and 6 and 8 and 808 and 1 000 000 etc). So we say: $x > 3$.

- All the numbers smaller than 0: $x < 0$. Like: -1 and -1,5 and -3,004 and -10 etc.
- Numbers larger than or equal to 6: $x \geq 6$. Write down five of them.

- All the numbers smaller than or equal to -2 : $x \leq -2$. Give three examples.

2.1 Use the variable y and write inequalities for the following descriptions:

All the numbers larger than -13 , 4 All the numbers smaller than or equal to π

3 We extend the idea further:

- All the numbers between 4 and 8: $4 < x < 8$. We also say: x lies between 4 and 8.
- Numbers larger than -3 and smaller than or equal to $-0,5$: $-3 < x \leq -0,5$.
- A is larger than or equal to 16 and smaller than or equal to 30: $16 \leq A \leq 30$.

It works best if you write numbers in the order in which they appear on the number line: the smaller number on the left and the bigger one on the right. Then you simply choose between either $<$ or \leq .

3.1 Now you and a friend must each give three descriptions in words. Then write the mathematical inequalities for one another's descriptions.

Inequalities – graphical representations

- Once again we use examples 2 and 3 above, but this time we draw diagrams.

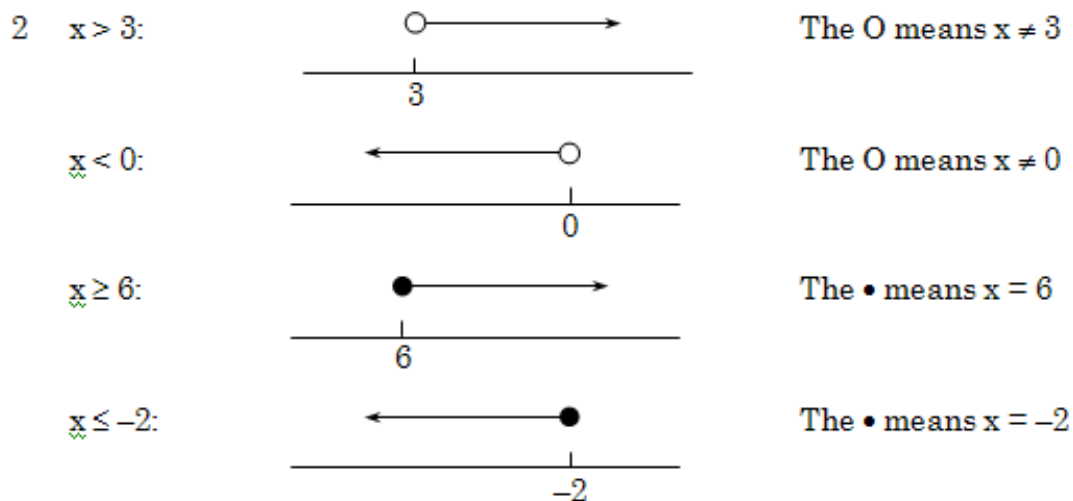

2.1 Draw the diagrams for the two questions.

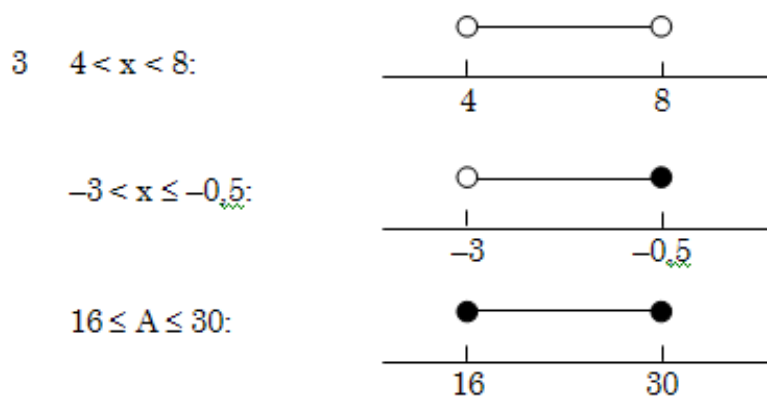

Figure 1.5

3.1 Again make your own diagrams.

end of ENRICHMENT ASSIGNMENT

GROUP ASSIGNMENT

1 CALCULATORS ARE NOW FORBIDDEN – DON'T DO ANY SUMS. ESTIMATE THE ANSWERS AS WELL AS YOU CAN AND FILL IN YOUR ESTIMATED ANSWERS. This assignment is the same as before – only you have to draw your own suitable number line for the numbers. First work alone, then the group must decide on the best answer. Fill this answer in on the group's number line. This group effort is then handed in for marking.

1.1 -8 ; 12 ; $5-11$; $4 + 0 - 4(\frac{1}{2})$; $\frac{36}{9} + \frac{12}{4} + \frac{22}{11} + 1$; $\sqrt[4]{81}$; $\sqrt{4} + \sqrt{9}$; $\sqrt{6} + 1$; $\sqrt[3]{27}$

1.2 $2,5 - \frac{1}{2}$; $\frac{1}{3}$; $1\frac{1}{3}$; $\frac{5}{6} - \frac{2}{6}$; $0,5$; $0,05$; $0,005$

1.3 3 ; $3,5$; $3,14$; 22 [U+FOB8] 7 ; 355 [U+FOB8] 113 ; [U+F010]

end of GROUP ASSIGNMENT

CLASS WORK

1 Of course one can write any number in many ways:

- 4 and 8 [U+FOB8] 2 and $1 + 3$ and $6 - 2$ and $\sqrt{16}$ and 2×2 are the same number!
- 0,5 and $\frac{5}{10}$ and $\frac{9}{18}$ and $\frac{50}{100}$ and $\sqrt{\frac{1}{4}}$ and $\frac{\sqrt{4}}{\sqrt{16}}$ are the same.

1.1 Is 1 [U+FOB8] 3 equal to 1,3? What about 1,33? And 1,33 of 1,333 of 1,3?

1.2 Is $\sqrt{5}$ the same as 2,2? Or 2,24? Or 2,236? Or 2,2361? Or maybe 2,2360? Discuss.

1.3 Is 3 and 3,5 and 3,14 and $22 \div 7$ and $355 \div 113$ the same as [U+F010] ? Make a decision.

2 We can't always write 3,1415926535897932384626 . . . when we want to use [U+F010]. Why not?

If I have to write down *exactly* what [U+F010] is, then I must write [U+F010] ! The others in question 1.3 are only *approximately* equal to [U+F010]. But when I have to use [U+F010] in a calculation to get an answer, then I have to be able to **round off** properly.

This is π rounded off to different *degrees of accuracy*:

1 decimal place: 3,1

2 decimal places: 3,14

3 decimal places: 3,142

4 decimal places: 3,1416

5 decimal places: 3,14159

6 decimal places: 3,141593

- You must *now* ensure that you know how to do rounding off correctly.

3 Simplify and round off the following values, accurate to the number of decimal places given in the brackets.

3.1 3,1 [U+FOB8] 3 (2)

3.2 $2 \times \sqrt{2}$ (2)

3.3 $5 \times [U+F010]$ (2)

3.4 $4,5 \times \sqrt{7}$ (0)

3.5 $1,000008 + 25$ [U+FOB8] 10000 (1)

end of CLASS WORK

How many seconds in a century?

CLASS WORK

1.1 How many hours are there in 17 weeks? $24 \times 7 \times 17 = 2\ 856$ hours

1.2 How many minutes in a week? $60 \times 24 \times 7 = 10\ 080$ minutes

1.3 Is it just as easy to calculate how many hours there are in 135 months? Discuss the question in a group and decide which questions have to be answered before the answer can be calculated.

1.4 How many years are there in 173 months? 173 [U+FOB8] $12 = 14,4166 \bar{6} \approx 14,42$ years

- The \approx sign means “approximately equal to” and is sometimes used to show that the answer has been rounded. It isn't used a lot, but it is a good habit.

2 Why do we *multiply* in question 1.1 and 1.2, and *divide* in question 1.4?

3 How many seconds in a century? It may take a while to get to the answer! How will you know that you can trust your answer?

4.1 There are one thousand metres in a kilometre, so we can say that one metre equals 0,001 kilometres. One metre = 1 [U+FOB8] 1000 kilometres or $1\text{ m} = \frac{1}{1000}\text{ km}$

4.2 There are one thousand millimetres in a metre: $1\text{ mm} = \frac{1}{1000 \times 1000}\text{ km} = 0,000\ 001\text{ km}$

4.3 There are one thousand micrometres in a millimetre: $1\ \mu\text{m} = 0,000\ 000\ 001\text{ km}$. (μ is a Greek letter – mu.)

5 Just as we can write very large numbers more conveniently in *scientific notation*, we also write very small numbers in scientific notation. Below are a few examples of each. Make sure that you can convert ordinary numbers to scientific notation, and vice versa. Calculators also use a sort of scientific notation. They differ, and so you have to make yourself familiar with the way your calculator handles very large and very small numbers.

5.1 $1\ \mu\text{m} = 0,000\ 000\ 001\text{ km}$ So: $1\ \mu\text{m} = 1,0 \times 10^{-9}\text{ km}$

- The definition of a *light year* is the distance that light travels in one year. Because light travels very fast, this is a huge distance. A light year is approximately $9,46 \times 10^{12}$ km. Write this value as an ordinary number.
- An electron has a mass of approximately 0,000 000 000 000 000 000 000 000 91g. What does this number look like in scientific notation?

5.2 On a typical lightweight bed sheet, there might be about three threads per millimetre, both across and lengthwise. If a sheet for a double bed measured two metres square, that would mean $6,0 \times 10^3$ threads across plus another $6,0 \times 10^3$ threads lengthwise. That gives us $1,2 \times 10^4$ threads, each about two metres long. Calculate how many kilometres of thread it took to make the sheet. Tonight, measure your pillowslip and do the same calculation for it.

5.3 A typical raindrop might contain about 1×10^{-5} litres of water. In parts of South Africa the annual rainfall is about 1 metre. On one hectare that means about 1×10^{12} raindrops per year. On a largish city that could mean about 6×10^{16} raindrops per year, or about 1×10^7 drops for every man, woman and child on Earth. How many litres each is that?

5.4 Calculate: (give answers in scientific notation)

$$5.4.1 \frac{3,501 \times 10^{-5}}{9,5 \times 10^{-8}} + 4,3 \times 10^{-11}$$

$$5.4.2 \frac{3,5 \times 10^6 + 1,4 \times 10^{-17}}{3,5 \times 10^6 - 1,4 \times 10^{-17}}$$

end of CLASS WORK

We use prefixes, mostly from Latin and Greek, to make names for units of measurement. For example, the standard unit of length is the *metre*. When we want to speak of ten metres, we can say one decametre; one hundred metres is a hectometre and, of course, one thousand metres is a kilometre. One tenth of a metre is a decimetre; one hundredth of a metre is a centimetre and one thousandth is a millimetre. There are other prefixes – see how many you can track down.

Your computer pals will be able to confirm, I hope, that in computers a “kilobyte” is really 1024 “bytes”. Now, why is it 1024 bytes and not 1000 bytes? The answer lies in the fact that computers work in the binary system and not in the decimal system like people. Try to find the answer yourself.

1.1.6 Assessment

Learning outcomes(LOs)
LO 1
Numbers, Operations and RelationshipsThe learner will be able to recognise, describe and represent numbers and their relationships, and to count, estimate, calculate and check with competence and confidence in solving problems.
Assessment standards(ASs)
We know this when the learner :
<i>continued on next page</i>

1.1 describes and illustrates the historical development of number systems in a variety of historical and cultural contexts (including local);
1.2 recognises, uses and represents rational numbers (including very small numbers written in scientific notation), moving flexibly between equivalent forms in appropriate contexts;
1.3 solves problems in context including contexts that may be used to build awareness of other learning areas, as well as human rights, social, economic and environmental issues such as:
1.3.1 financial (including profit and loss, budgets, accounts, loans, simple and compound interest, hire purchase, exchange rates, commission, rentals and banking);
1.3.2 measurements in Natural Sciences and Technology contexts;
1.4 solves problems that involve ratio, rate and proportion (direct and indirect);
1.5 estimates and calculates by selecting and using operations appropriate to solving problems and judging the reasonableness of results (including measurement problems that involve rational approximations of irrational numbers);
1.6 uses a range of techniques and tools (including technology) to perform calculations efficiently and to the required degree of accuracy, including the following laws and meanings of exponents (the expectation being that learners should be able to use these laws and meanings in calculations only):
1.6.1 $x^n \times x^m = x^{n+m}$
1.6.2 $x^n \div x^m = x^{n-m}$
1.6.3 $x^0 = 1$
1.6.4 $x^{-n} = \frac{1}{x^n}$
1.7 recognises, describes and uses the properties of rational numbers.

Table 1.1

1.1.7 Memorandum

CLASS WORK

1.1 Yes, any informal “proof” is acceptable.

1.2 As 1.1

1.3 Zero and negative numbers make an appearance. The explanation is not important – only the thinking that the learner does.

2.1 $N_0 = \{0; 1; 2; \dots\}$ and $Z = \{\dots -3; -2; -1; 0; 1; 2; 3; \dots\}$

3. Here are the fractions. Explain carefully that integers can also be written as fractions – in fact it is quite often a useful technique.

4.1 Not everyone will be able to cope with this. R' gives the answers that are obtained when square roots of negative numbers (inter alia) is taken.

TASK

2. Point out to learners that zero is missing from the table.

HOMEWORK ASSIGNMENT

1. Zero is needed because:

The principle behind place values is totally dependent on having a symbol for zero.

It separates positive and negative numbers.

It symbolises “nothing”.

Algebraically it is defined as: $a + (-a)$

2. Complex numbers – don’t expect too much.

If one uses the symbol i for $\sqrt{-1}$, then we can represent non-real numbers as follows: $\sqrt{-12} = 2\sqrt{-3} = 2\sqrt{3} \times \sqrt{-1} = 2\sqrt{3}\sqrt{-1} = 2\sqrt{3}i$

$3 + 5i$ and $2,5 - 16i$ are examples of non-real numbers, and each consists of two parts: a real part and a non-real part. The most important consequences of this are that one must be careful when doing arithmetic calculations, and that these numbers cannot be arranged in ascending order!

3. Any reasonable answer can be accepted. This might be a good opportunity to have learners evaluating each other's number systems.

ENRICHMENT ASSIGNMENT

If there is time, one can go through this work, particularly with a strong group.

4.1 Non-repeating; although 3,030030003000030... has a pattern, it does not repeat.

4.2 Emphasise that the first one is NOT equal to π . The two others must be simplified properly.

4.3.1 $\frac{1553}{1000}$

4.3.2 $\frac{51}{90}$

4.3.3 $\frac{30311}{999}$

4.3.4 $\frac{2403}{990}$

CLASS ASSIGNMENT

The aim of this exercise is to familiarise learners with unsimplified values, so that they can learn to estimate. It is very important that they mentally simplify correctly so that they can start guessing the magnitudes. Then the values have to be arranged in at least the correct order. If the spaces in between are in reasonable proportion, that is a bonus. This shows the order:

1.1 0,00 ; 1 ; 2 ; 3,0 ; 4 ; 5,0000 ; 5+2 ; 6 ; 9-1

1.2 -4 ; -3 ; -1 ; 3-3 ; 2 ; 5

1.3 $\frac{1}{5}$; $\frac{1}{4}$; 0.666 ; $\frac{2}{3}$; $\frac{2}{2}$; 1,000 ; 0,2+1 ; 1.75

1.4 $\frac{3}{2} - 12$; $-8 + \frac{7}{5}$; -5,5 ; $-\frac{5}{2}$; -2,5 ; 5,55 ; $\frac{14}{2}$

1.5 $-\sqrt{9}$; $-\sqrt{4}$; $\sqrt{0}$; $\sqrt{1}$; $\sqrt{\frac{9}{4}}$; $\frac{\sqrt{16}}{2}$; $\sqrt{9}$; $\sqrt{36}-1$

1.6 $\sqrt{4}$; $\sqrt{6}$; $\sqrt{9}$; $\sqrt{16}$; $\sqrt{25}$; $\sqrt{20}+1$; $\sqrt{32}$; $\sqrt{36}$

ENRICHMENT ASSIGNMENT

1.1 $5,6 < 5,7$; $3+9 = 4 \times 3$; $-1 > -2$; $3 > -3$; $\sqrt[3]{27} < \sqrt{15}$

2.1 $y > -13,4$

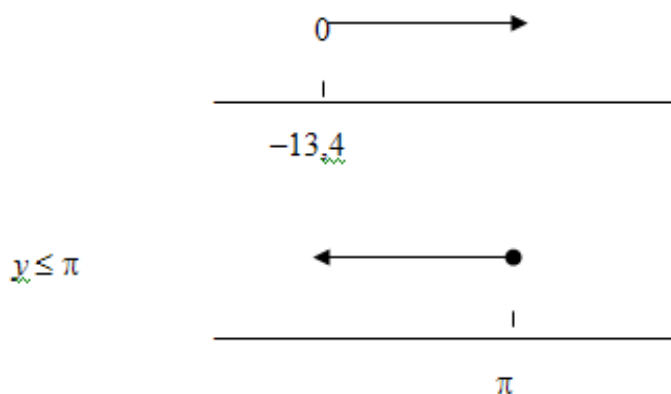

Figure 1.6

GROUP ASSIGNMENT

These are the simplified values in the original order:

1.1 -8 ; 12 ; -6 ; 2 ; 10 ; 3 ; 5 ; 3,44... ; 3

1.2 2 ; 0,3... ; 1,3... ; 0,5 ; 0,5 ; 0,05 ; 0,005

1.3 3 ; 3,5 ; 3,14 ; 3,142857... ; 3,1415929... ; 3,1415926... (the last one is π)

These are the same values in the correct order:

1.1 -8 ; -6 ; 2 ; 3 ; 3,44... ; 5 ; 10 ; 12

1.2 0,005 ; 0,05 ; 0,3... ; 0,5 ; 1,3... ; 2

1.3 3 ; 3,14 ; π ; 3,1415929... ; 3,142857...

CLASS WORK

This exercise has been designed to give learners a feeling for the consequences of rounding (approximated answers). They often put complete unthinking faith in their calculators' answers.

1.1 Note the notation as well as the number of decimal places.

1.2 Again, notation as well as number of decimal places.

1.3 Emphasise once again that an approximation to π is not *equal* to π .

Discuss the meaning of the term "approximately equal to".

3. Answers: 1,03 ; 2,83 ; 15,71 ; 12 ; 1,0 (the zero must be there).

CLASS WORK

Learners often have difficulties with conversions – you might have to supply lots of help and guidance.

1.3 The months don't have the same number of days; simply multiplying will not give the best answer.

Find out which months are meant and don't forget leap years!

1.4 Why division? Help them develop strategies.

3. Similar problems to 1.3. The answer can be approximated. Explain why this acceptable. This problem will motivate them to appreciate the advantages of scientific notation: $\approx 3\ 157\ 056\ 000$ seconds.

5.1 $9,1 \times 10^{28}$

5.2 24 km

5.3 100 litres

α

Figure 1.7

1.2 Easier algebra with exponents²

1.2.1 MATHEMATICS

1.2.2 Grade 9

1.2.3 NUMBERS

1.2.4 Module 2

1.2.5 EASIER ALGEBRA WITH EXPONENTS

Easier algebra with exponents

CLASS WORK

- Do you remember how exponents work? Write down the meaning of “three to the power seven”. What is the base? What is the exponent? Can you explain clearly what a power is?
- In this section you will find many numerical examples; use your calculator to work through them to develop confidence in the methods.

1 DEFINITION

$$2^3 = 2 \times 2 \times 2 \text{ and } a^4 = a \times a \times a \times a \text{ and } b \times b \times b = b^3$$

also

$$(a+b)^3 = (a+b) \times (a+b) \times (a+b) \text{ and } \left(\frac{2}{3}\right)^4 = \left(\frac{2}{3}\right) \times \left(\frac{2}{3}\right) \times \left(\frac{2}{3}\right) \times \left(\frac{2}{3}\right)$$

1.1 Write the following expressions in expanded form:

$$4^3 ; (p+2)^5 ; a^1 ; (0,5)^7 ; b^2 \times b^3 ;$$

1.2 Write these expressions as powers:

$$7 \times 7 \times 7 \times 7$$

$$y \times y \times y \times y \times y$$

$$-2 \times -2 \times -2$$

$$(x+y) \times (x+y) \times (x+y) \times (x+y)$$

1.3 Answer without calculating: Is $(-7)^6$ the same as -7^6 ?

- Now use your calculator to check whether they are the same.
- Compare the following pairs, but first guess the answer before using your calculator to see how good your estimate was.

$$-5^2 \text{ and } (-5)^2 \quad -12^5 \text{ and } (-12)^5 \quad -1^3 \text{ and } (-1)^3$$

- By now you should have a good idea how brackets influence your calculations – write it down carefully to help you remember to use it when the problems become harder.

- The definition is:

$a^r = a \times a \times a \times a \times \dots$ (There must be r a 's, and r must be a natural number)

²This content is available online at <http://cnx.org/content/m31943/1.1/>.

- It is good time to start memorising the most useful powers:

$$2^2 = 4; 2^3 = 8; 2^4 = 16; \text{ etc. } 3^2 = 9; 3^3 = 27; 3^4 = 81; \text{ etc. } 4^2 = 16; 4^3 = 64; \text{ etc.}$$

Most problems with exponents have to be done without a calculator!

2 MULTIPLICATION

- Do you remember that $g^3 \times g^8 = g^{11}$? Important words: multiply; same base

2.1 Simplify: (don't use expanded form)

$$7^7 \times 7^7$$

$$(-2)^4 \times (-2)^{13}$$

$$\left(\frac{1}{2}\right)^1 \times \left(\frac{1}{2}\right)^2 \times \left(\frac{1}{2}\right)^3$$

$$(a+b)^a \times (a+b)^b$$

- We multiply powers with the same base according to this rule:

$$a^x \times a^y = a^{x+y} \text{ also } a^{x+y} = a^x \times a^y = a^y \times a^x, \text{ e.g. } 8^{14} = 8^4 \times 8^{10}$$

3 DIVISION

- $\frac{4^6}{4^2} = 4^{6-2} = 4^4$ is how it works. Important words: divide; same base

3.1 Try these: $\frac{a^6}{a^y}$; $\frac{3^{23}}{3^{21}}$; $\frac{(a+b)^p}{(a+b)^{12}}$; $\frac{a^7}{a^7}$

- The rule for dividing powers is: $\frac{a^x}{a^y} = a^{x-y}$.

$$\text{Also } a^{x-y} = \frac{a^x}{a^y}, \text{ e.g. } a^7 = \frac{a^{20}}{a^{13}}$$

4 RAISING A POWER TO A POWER

- e.g. $(3^2)^4 = 3^{2 \times 4} = 3^8$.

4.1 Do the following:

$$(a^a)^5 ; \quad \left(\left(\frac{1}{3} \right)^7 \right)^5 ; \quad (0,4^a)^b ; \quad (x^a)^a ; \quad (6^5)^{(a-1)}$$

Figure 1.8

- This is the rule: $(a^x)^y = a^{xy}$ also $a^{xy} = (a^x)^y = (a^y)^x$, e.g. $6^{18} = (6^6)^3$

5 THE POWER OF A PRODUCT

- This is how it works:

$$(2a)^3 = (2a) \times (2a) \times (2a) = 2 \times a \times 2 \times a \times 2 \times a = 2 \times 2 \times 2 \times a \times a \times a = 8a^3$$

- It is usually done in two steps, like this: $(2a)^3 = 2^3 \times a^3 = 8a^3$

5.1 Do these yourself: $(4x)^2$; $(ab)^6$; $(3 \times 2)^4$; $(\frac{1}{2}x)^2$; $(a^2 b^3)^2$

- It must be clear to you that the exponent belongs to each factor in the brackets.
- The rule: $(ab)^x = a^x b^x$ also $a^p \times b^p = (ab)^p$ e.g. $14^3 = (2 \times 7)^3 = 2^3 7^3$ and $3^2 \times 4^2 = (3 \times 4)^2 = 12^2$

6 A POWER OF A FRACTION

- This is much the same as the power of a product. $(\frac{a}{b})^3 = \frac{a^3}{b^3}$

6.1 Do these, but be careful: $(\frac{2}{3})^p (\frac{-2}{2})^3 (\frac{x^2}{y^3})^2 (\frac{a^{-x}}{b^{-y}})^{-2}$

- Again, the exponent belongs to both the numerator and the denominator.
- The rule: $(\frac{a}{b})^m = \frac{a^m}{b^m}$ and $\frac{a^m}{b^m} = (\frac{a}{b})^m$ e.g. $(\frac{2}{3})^3 = \frac{2^3}{3^3} = \frac{8}{27}$ and $\frac{a^{2x}}{b^x} = \frac{(a^2)^x}{b^x} = (\frac{a^2}{b})^x$

end of CLASS WORK

TUTORIAL

- Apply the rules together to simplify these expressions without a calculator.

- $\frac{a^5 \times a^7}{a \times a^8}$
- $\frac{x^3 \times y^4 \times x^2 y^5}{x^4 y^8}$
- $(a^2 b^3 c)^2 \times (ac^2)^2 \times (bc)^2$
- $a^3 \times b^2 \times \frac{a^3}{a} \times \frac{b^5}{b^4} \times (ab)^3$
- $(2xy) \times (2x^2 y^4)^2 \times \left(\frac{(x^2 y)^3}{(2xy)^3}\right)$
- $\frac{2^3 \times 2^2 \times 2^7}{8 \times 4 \times 8 \times 2 \times 8}$

end of TUTORIAL

Some more rules

CLASS WORK

1 Consider this case: $\frac{a^5}{a^3} = a^{5-3} = a^2$

- Discuss the following two problems, and make two more rules to cover these cases.

1.1 $\frac{a^3}{a^3}$ 1.2 $\frac{a^3}{a^5}$

2 WHEN THE EXPONENT IS ZERO

- The answer to 1.1 is a^0 when we apply the rule for division.
- But we *know* that the answer must be 1, because the numerator and denominator are the same.
- So, we can say that *anything* with a zero as exponent must be equal to 1.
- The rule is now: $a^0 = 1$ also $1 = a^0$. A few examples:

$3^0 = 1$; $k^0 = 1$; $(ab^2)^0 = 1$; $(n+1)^0 = 1$; $\left(\frac{a^3 b}{(ab^2)^2}\right)^0 = 1$ and

$1 = (\text{anything})^0$, in other words, we can change a 1 to anything that suits us, if necessary!

3 WHEN THE EXPONENT IS NEGATIVE

- Look again at 1.2. According to the rule, the answer is a^{-2} . But what does it mean?
- $\frac{a^3}{a^5} = \frac{a \times a \times a}{a \times a \times a \times a \times a} = \frac{1}{a \times a} = \frac{1}{a^2}$.
- So the rule is: $a^{-x} = \frac{1}{a^x}$ and vice versa.
- From now on we always try to write answers with positive exponents, where possible.
- The rule also means: $\frac{1}{a^{-x}} = a^x$ and vice versa. These examples are important:

$$ab^2 c^{-3} = \frac{ab^2}{c^3}$$

$$2x^{-m} y = \frac{2y}{x^m}$$

$$\frac{a^2 b^{-5}}{a^{-3} b^5} = \frac{a^2 a^3}{b^5 b^5} = \frac{a^5}{b^{10}} \quad (1.1)$$

end of CLASS WORK

HOMEWORK ASSIGNMENT

- Simplify without a calculator and leave answers without negative exponents.

- $x^3y^2 \times 3^2x^2y \times 2xy^4$
- $\frac{x^4}{3xy^2} \times \frac{6x^2}{x^3y} \times 2x^7y^3 \times \frac{4x^2y^4}{2y}$
- $(5^x)^3 - (5^3)^x$
- $(2a^2b^5c^3d)^2 \times 2a(bc^2d)^3 \times 4ab(cd^3)^2$
- $6\left(\frac{x^2}{y}\right)^2 \times \left(\frac{2x}{y^3}\right)^3 \times \frac{x^4}{3xy}$
- $(2a^2)^3 + (12a^3)^0 - 8a^6$
- $x^3y^{-4} \times (3^{-1}x^2y^{-1})^{-3} \times (2xy^3)^2$

end of HOMEWORK ASSIGNMENT
CLASS WORK

- Let us make sure that we can replace variables with numerical values properly.

1 To calculate the perimeter of a rectangle with side lengths 17cm and 13,5 cm, we use normal formula:

- Perimeter = 2 [length + breadth]
- Put brackets in place of the variables: = 2 [() + ()]
- Fill in the values: = 2 [(17) + (13,5)]
- Remove brackets and simplify = 2 [17 + 13,5] according to the rules: = 2 × 20,5
- Remember the units (if any): = 41 cm

2 What is the value of $\frac{x^3 \times y^4 \times x^2 y^5}{x^4 y^8}$ if x = 3 and y = 2 ?

- There are two possibilities: first substitute and then simplify or simplify first and then substitute. Here are both methods:

$$\frac{x^3 \times y^4 \times x^2 y^5}{x^4 y^8} = \frac{(3)^3 \times (2)^4 \times (3)^2 \times (2)^5}{(3)^4 \times (2)^8} = \frac{27 \times 16 \times 9 \times 32}{81 \times 128} = 3 \times 2 = 6$$

$$\frac{x^3 \times y^4 \times x^2 y^5}{x^4 y^8} = \frac{x^3 \times x^2 \times y^4 \times y^5}{x^4 \times y^8} = \frac{x^5 \times y^9}{x^4 \times y^8} = x^{5-4} \times y^{9-8} = x \times y = (3) \times (2) = 6$$

- Without errors, the answers will be the same.

3.1 Calculate the perimeter of the square with side length 6,5 cm

3.2 Calculate the area of the rectangle with side lengths 17 cm and 13,5 cm.

3.3 If a = 5 and b = 1 and c = 2 and d = 3, calculate the value of: $(2a^2b^5c^3d)^2 \times 2a(bc^2d)^3 \times 4ab(cd^3)^2$.

end of CLASS WORK

Assessment

Exponents ω

I can . . .	ASs	[U+F04A]	[U+F04B]	[U+F04C]	Now I have to . . .
Recognise which rules to use	1.6				<
Simplify expressions with exponents	2.8				
Give answers with positive exponents	1.6.4				
Use scientific notation	1.6.1				
Do substitutions	1.6				
Apply formulae	1.6				>

Table 1.2[U+F04A] *good* [U+F04B] *average* [U+F04C] *not so good*

For this learning unit I . . .			
Worked very hard	yes	no	
Neglected my work	yes	no	
Did very little work	yes	no	<i>Date:</i>

Table 1.3

Learner can . . .	ASs	1	2	3	4	Comments
Recognise which rules to use	1.6					
Simplify expressions with exponents	2.8					
Give answers with positive exponents	1.6.4					
Use scientific notation	1.6.1					
Do substitutions	1.6					
Apply formulae	1.6					

Table 1.4

Critical outcomes	1	2	3	4
Cooperative group work				
Communication using symbols properly				
Accuracy				
Understanding of Maths in everyday life				

Table 1.5

Educator:
Signature: <i>Date:</i>

Table 1.6

Feedback from parents:
Signature: <i>Date:</i>

Table 1.7**1.2.6 Assessment**

Learning outcomes(LOs)
LO 1
Numbers, Operations and RelationshipsThe learner will be able to recognise, describe and represent numbers and their relationships, and to count, estimate, calculate and check with competence and confidence in solving problems.
Assessment standards(ASs)
<i>We know this when the learner :</i>
1.1 describes and illustrates the historical development of number systems in a variety of historical and cultural contexts (including local);
1.2 recognises, uses and represents rational numbers (including very small numbers written in scientific notation), moving flexibly between equivalent forms in appropriate contexts;
1.3 solves problems in context including contexts that may be used to build awareness of other learning areas, as well as human rights, social, economic and environmental issues such as:
1.3.1 financial (including profit and loss, budgets, accounts, loans, simple and compound interest, hire purchase, exchange rates, commission, rentals and banking);
1.3.2 measurements in Natural Sciences and Technology contexts;
1.4 solves problems that involve ratio, rate and proportion (direct and indirect);
1.5 estimates and calculates by selecting and using operations appropriate to solving problems and judging the reasonableness of results (including measurement problems that involve rational approximations of irrational numbers);
1.6 uses a range of techniques and tools (including technology) to perform calculations efficiently and to the required degree of accuracy, including the following laws and meanings of exponents (the expectation being that learners should be able to use these laws and meanings in calculations only):
1.6.1 $x^n \times x^m = x^{n+m}$
1.6.2 $x^n \div x^m = x^{n-m}$
1.6.3 $x^0 = 1$
1.6.4 $x^{-n} = \frac{1}{x^n}$
1.7 recognises, describes and uses the properties of rational numbers.
LO 2
<i>continued on next page</i>

Patterns, Functions and Algebra The learner will be able to recognise, describe and represent patterns and relationships, as well as to solve problems, using algebraic language and skills.
We know this when the learner :
2.8 uses the laws of exponents to simplify expressions and solve equations.

Table 1.8

1.2.7 Memorandum

TEST 2

1. Scientific Notation

1.1 Write the following values as ordinary numbers:

1.1.1 $2,405 \times 10^{17}$

1.1.2 $6,55 \times 10^{-9}$

1.2 Write the following numbers in scientific notation:

1.2.1 5 330 110 000 000 000 000

1.2.2 0,000 000 000 000 000 013 104

1.3 Do the following calculations and give your answer in scientific notation:

1.3.1 $(6,148 \times 10^{11}) \times (9\ 230\ 220\ 000\ 000\ 000)$

1.3.2 $(1,767 \times 10^{-6}) [U+FOB8] (6,553 \times 10^{-4})$

2. Exponents

Simplify and leave answers without negative exponents. (Do not use a calculator.)

2.1 $3a^2xy(3ab^2x^2y)^3$

2.2 $\frac{(a^0b^0c)^3}{6c^2(ab^3c^5)^2} \times \frac{2(3a^2c^3)^0}{4abc^2} \times 18b^4(2a^3c^4)^2$

3. Substitution

3.1 Simplify: $2x^2y^3 + (xy)^2 - 4x$

3.2 Calculate the value of $2x^2y^3 + (xy)^2 - 4x$ as $x = 4$ and $y = -2$

4. Formulae

the formula for the area of a circle is: $\text{area} = \pi r^2$ (r is the radius).

4.1 Calculate the areas of the following circles:

4.1.1 A circle with radius = 12 cm ; round answer to 1 decimal place.

4.1.2 A circle with a diameter 8 m ; approximate to the nearest metre.

TEST 2

1.1.1 240 500 000 000 000 000

1.1.2 0,000 000 006 55

1.2.1 $5,330\ 110 \times 10^{18}$

1.2.2 $1,3104 \times 10^{-17}$

1.3.1 $6,148 \times 10^{11} \times 9,23022 \times 10^{15}$

$= 6,148 \times 9,23022 \times 10^{11} \times 10^{15}$

$\approx 56,74 \times 10^{26}$

$= 5,674 \times 10^{27}$

1.3.2 $\frac{1,767 \times 10^{-6}}{6,553 \times 10^{-4}} = \frac{1,767}{6,553} \times 10^{-6-(-4)} \approx 0,26 \times 10^{-2} = 2,6 \times 10^{-1}$

2.1 $3^4 a^5 x^7 y^4 = 81 a^5 x^7 y^4$

2.2 $\frac{c^3 \times 2 \times 18 a^6 b^4 c^8}{6 a^2 b^6 c^{12} \times 4 abc^2} = \frac{36 a^6 b^4 c^{11}}{24 a^3 b^7 c^{14}} = \frac{3 a^3}{2 b^3 c^3}$

3.1 $2x^2y^3 + x^2y^2 - 4x$

3.2 $2(4)^2(-2)^3 + (4)^2(-2)^2 - 4(4) = 2(16)(-8) + (16)(4) - 16 = -256 + 64 - 16 = -208$

4.1.1 opp $= \pi \times 12^2 = 452,38934 \dots \approx 452,4 \text{ cm}^2$

4.1.2 opp $= \pi \times 4^2 = 50,26548 \dots \approx 50 \text{ m}^2$

CLASS WORK

The learners are likely to know the work in the first part already. Those who have not mastered the simplest laws of exponents now have an opportunity to catch up. For the rest it serves as revision in preparation for the new work in the second part.

1.1 $4 \times 4 \times 4 (p+2) \times (p+2) \times (p+2) \times (p+2) \times (p+2)$ etc.

1.2 $7^4 y^5$ etc.

1.3 $(-7)^6 = 7^6$, $(-7)^6 \neq -7^6$ etc.

2.1 $7^{14} (-2)^{17} = -2^{17}$ etc.

3.1 $a^6 y 3^2 (a+b)^{p-12} a^0$

4.1 $a^5 a$ etc.

TUTORIAL

The tutorial should be done in silence in class in a fixed time. Recommendation: Mark it immediately – maybe the learners can mark one another’s work.

Answers: 1. a^3

2. xy

3. $a^6 b^8 c^8$

4. $a^8 b^6$

5. $4x^8 y^9$

6. 1

CLASS WORK

New for most learners in grade 9.

HOMEWORK ASSIGNMENT

Answers:

1. $18x^6 y^7$

2. $24x^{11} y^3$

3. 0

4. $32a^6 b^{14} c^{14} d^{11}$

5. $\frac{16x^{10}}{y^{12}}$

6. 1

7. $\frac{108y^5}{x}$

CLASS WORK

Substitution gives lots of trouble because it looks so easy. Learners who leave out steps (or don’t write them down) often make careless mistakes. Force them to use brackets.

2. They should conclude that simplification should come first – after all, this is why we simplify!

3.1 26 cm

3.2 229,5 cm²

3.3 $\approx 1,45 \times 10^{15}$

1.3 Why all the fuss about Pythagoras?³

1.3.1 MATHEMATICS

1.3.2 Grade 9

1.3.3 NUMBERS

1.3.4 Module 3

1.3.5 WHY ALL THIS FUSS ABOUT PYTHAGORAS?

INVESTIGATION

³This content is available online at <<http://cnx.org/content/m31205/1.1/>>.

1.1 Work in a group but start on your own by drawing three right-angled triangles of different shapes and sizes. Work as accurately as possible. It will be a lot easier if you use squared paper. Now work even more accurately and measure the three sides of each triangle to the nearest millimetre. Complete the first three rows of the table. Now use your calculator to complete the rest of the table.

	SYMBOL	TRIANGLE A	TRIANGLE B	TRIANGLE C
Length of the shortest side	a
Length of the medium side	b
Length of the longest side	c
Square of the length of the shortest side	a^2
Square of the length of the medium side	b^2
Sum of the two squares above	$a^2 + b^2$
Square of the length of the longest side	c^2

Table 1.9

1.2 There should be something interesting about the shaded cells of the table. In your group write down carefully what you notice and (if you can) why it happens.

2. Take three lines:

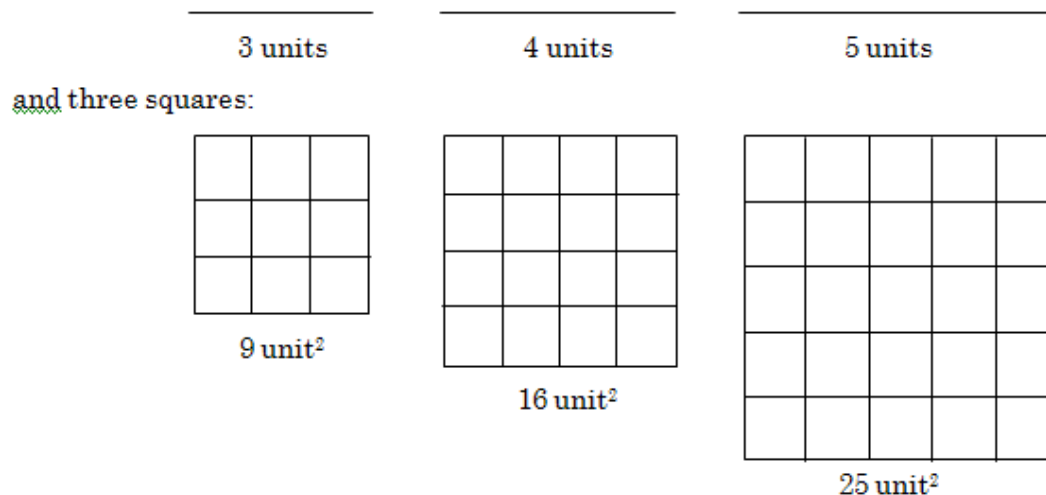

Figure 1.9

- The three given lines can be used to form a right-angled triangle.

Cutting-out:

2.1 Can the three given squares be used to form a triangle?

3 Write a neat summary of the results of the investigation.

end of INVESTIGATION

The Theorem of Pythagoras goes:

- *In a right-angled triangle, the square on the hypotenuse is equal to the sum of the squares on the other two sides.*

The importance of the Theorem of Pythagoras is that we use it in two ways: Firstly, if we know that a triangle is right angled, then we can say something very important about its sides. Secondly, if we know that the three sides of a triangle have a certain relationship with each other, then we also know that the triangle must be right-angled.

CLASS WORK

1 We label triangles as follows:

- Refer to the sketch alongside.
- The three vertices (corners) get capital letters. (A, B and C).
- The sides can be named as the two vertices betweenwhich the side lies (AB, BC and AC), or we can use lowercase letters, each corresponding to the vertexopposite the side (a, b and c).

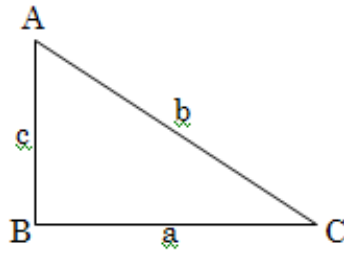

Figure 1.10

- At the moment we are dealing with right-angled triangles, but all triangles are labelled the same way.

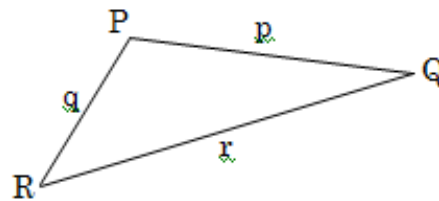

Figure 1.11

- We also use the same letter to refer *both* to the name of a side *and* to its length.
- E.g. $PR = 3,5\text{cm}$ or $r = 5\text{cm}$. $\triangle PRS$ means: triangle PRS

REMEMBER always to use a ruler for good sketches!

- In the following exercise the first problem is always an example.

2 *Problem*: AEH has a right angle at H. $AH = 6\text{cm}$ and $EH = 8\text{cm}$. Draw a sketch (not accurate) of the triangle and use the Theorem of Pythagoras to calculate the length of side AE.

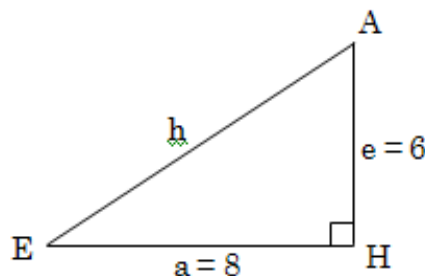

Figure 1.12

Solution: Because we know that the triangle has a rightangle, we are allowed to say that $AE^2 = AH^2 + EH^2$ (or: $h^2 = e^2 + a^2$)

Substitution: $AH^2 + EH^2 = (6)^2 + (8)^2 = 36 + 64 = 100 \text{ cm}^2$ If $E^2 = 100 \text{ cm}^2$, then AE must be 10 cm.

2.1 Calculate the length of the third side of these triangles:

2.1.1 $\triangle DEF$ with $\angle D$ a right angle and $e = 5 \text{ mm}$ and $f = 12 \text{ mm}$

2.1.2 $\triangle XYZ$ with $\angle Y$ a right angle and $x = 3 \text{ cm}$ and $y = 5 \text{ cm}$.

3 *Problem:* What is the length of the shortest side (b) of the right-angled $\triangle ABC$ if the other two sides are 6 cm and 9 cm? $\angle C$ is the right angle.

Solution: In a right-angled triangle the longest side is always the hypotenuse: the side opposite the right angle. Now we use the Theorem of Pythagoras in the other form.

- If b is the shortest side, and $\angle C$ is a right angle, then c must be the longest side. So, you use:

$$b^2 = c^2 - a^2 \text{ (note carefully where } b^2 \text{ is, and that we subtract)}$$

$$b^2 = (9)^2 - (6)^2 = 81 - 36 = 45 \text{ cm}^2 \text{ Calculator time!}$$

$$b^2 = 45. \text{ Use the } \sqrt{\quad} \text{- button on the calculator to find the value of } b.$$

- Your calculator supplies the answer: $b = 6,7082039 \dots$ et cetera. But is this a sensible answer? Discuss whether the approximated (rounded) answer of 6,7cm is good enough for our purposes.

3.1.1 Calculate the length of the hypotenuse of a triangle with both of the other sides equal to 9 cm. (Label the triangle yourself.)

3.1.2 $\triangle PQR$ is right-angled and isosceles. Calculate the length of PR, if the hypotenuse is 13,5 cm.

4 *Problem:* Is $\triangle GHK$ right-angled if $GK = 24 \text{ cm}$, $GH = 26 \text{ cm}$ and $HK = 10 \text{ cm}$?

Solution: In this problem we know all *three* the sides' lengths. If we want to find out whether it is right-angled, we have to confirm whether $(\text{hypotenuse})^2 = (\text{one side})^2 + (\text{other side})^2$.

The hypotenuse is always the longest side. We have a very specific method whenever we have to *confirm* a result. We calculate the left-hand side and the right-hand side of the equation separately. Thus:

- Left-hand side = $(\text{hypotenuse})^2 = 26^2 = 676 \text{ cm}^2$
- Right-hand side = $(\text{one side})^2 + (\text{other side})^2 = 24^2 + 10^2 = 576 + 100 = 676 \text{ cm}^2$
- Because the left-hand side and right-hand side come out the same, we can conclude that the triangle is right-angled.
- Is it possible to know which angle is the right angle? You give the answer!

4.1 Are the triangles with the given side lengths right-angled? Which angle is the right angle?

4.1.1 $a = 30$ mm, $b = 40$ mm and $c = 50$ mm.

4.1.2 $p = 8$ cm, $q = 13$ cm and $r = 15$ cm.

4.1.3 $MN = 15,56$ cm, and $NP = MP = 11$ cm.

end of CLASS WORK

HOMEWORK ASSIGNMENT

1 Find the third side of the following triangles:

1.1 $\triangle ABC$ with $C = 90^\circ$ and $b = 5$ mm and $c = 13$ mm

1.2 $\triangle MNO$ with O the right angle and $m = 6$ cm and $n = 8$ cm.

2 Determine whether the following triangles are right-angled, and which angle is 90° .

2.1 $a = 9$ mm, $b = 11$ mm and $c = 13$ cm

2.2 $XZ = 85$ mm, $XY = 13$ mm and $YX = 86$ mm.

end of HOMEWORK ASSIGNMENT

The connection between roots and exponents

CLASS WORK

1 Eight of the equations in this list must be filled in the second row of the table under the equation in the top row where each fits the best.

$\sqrt{25} = 5$; $b = \sqrt{b^2}$; $\sqrt{9} = 3$; $\sqrt[6]{64} = 2$; $\sqrt[3]{a^3} = a$; $\sqrt[3]{8} = 2$;
 $\sqrt[4]{81} = 3$; $\sqrt{64} = 8$; $\sqrt{49} = 7$

Exponential form	$2^3 = 8$	$9 = 3^2$	$25 = 5^2$	$7^2 = 49$	$3^4 = 81$	$b \times b = b^2$	$64 = 2^6$	$a \times a \times a = a^3$
Root form

Table 1.10

2 A radical is an expression with a root sign. How to simplify radicals. Example: $\sqrt{2ab^3c \times 8abc^5}$.

- The most important step is to write the expression under the root sign as simply as possible as products of powers: $\sqrt{2ab^3c \times 8abc^5} = \sqrt{2^4a^2b^4c^6}$.
- As we are working with a square root we group them into squares: $\sqrt{2^4a^2b^4c^6} = \sqrt{(2^2ab^2c^3)^2}$
- and remove the root sign, so: $\sqrt{2ab^3c \times 8abc^5} = \sqrt{(2^2ab^2c^3)^2} = 2^2ab^2c^3 = 4ab^2c^3$
- Another example: $\sqrt[3]{16x^2y^5 \times 2x^2y}$
- Write as products of powers: $\sqrt[3]{16x^2y^5 \times 2x^2y} = \sqrt[3]{2^4x^2y^5 \times 2x^2y} = \sqrt[3]{2^5x^4y^6}$
- This is a third root, so we group into third powers: $\sqrt[3]{2^5x^4y^6} = \sqrt[3]{2^3x^3y^6 \times 2^2x^1} = \sqrt[3]{(2xy^2)^3 \times 4x}$
- We can now remove the root sign over the part that can be simplified. $\sqrt[3]{(2xy^2)^3 \times 4x} = 2xy^2\sqrt[3]{4x}$
- The simplified part is a coefficient; the rest remains as a radical.

Please note that this can be done only if the root contains factors. In other words, it cannot be done with a sum expression.

- Simplify these radicals as far as possible:

2.1 $\sqrt{25a^5b^3c^2}$

2.2 $\sqrt[3]{81x^9y^{12}}$

2.3 $\sqrt{16(a+b)^2}$

end of CLASS WORK

ENRICHMENT ASSIGNMENT

1 As you may have noticed, most right-angled triangles do not have natural numbers as side lengths. But those that do have whole-number side lengths are very interesting. The well-known (3 ; 4 ; 5)-triangle is one example. These groups of three numbers are called *Pythagorean triples*.

1.1 Take groups of three numbers from these numbers, trying to find all the Pythagorean triples you can.
3 ; 4 ; 5 ; 12 ; 13 ; 35 ; 36 ; 37 ; 77 ; 84 ; 85

end of ENRICHMENT ASSIGNMENT

There are many different ways to prove the Theorem of Pythagoras.

- An American mathematician had a hobby of collecting as many different proofs as he could. He eventually published a book of these proofs – over four hundred.

AssessmentPythagoras ω

<i>I can . . .</i>	ASs	[U+F04A]	[U+F04B]	[U+F04C]	Now I have to . . .
Name triangles correctly	4.4				<
Use Pythagoras to calculate sides	4.4				
Identify right-angled triangles	4.4				
Calculate square roots	4.4				>

Table 1.11[U+F04A] *good* [U+F04B] *average* [U+F04C] *not so good*

For this learning unit . . .			
I worked very hard	yes	no	
I neglected my work	yes	no	
Did very little	yes	no	<i>Date:</i>

Table 1.12

Learner can . . .	ASs	1	2	3	4	Remarks
Name triangles correctly	4.4					
Use Pythagoras to calculate sides	4.4					
Identify right-angled triangles	4.4					
Calculate square roots	4.4					

Table 1.13

Critical outcomes	1	2	3	4
Identification and creative solution of problems				
Diagrammatic communication				
Accuracy				
Cooperation in groups				

Table 1.14

Educator:
Signature: <i>Date:</i>

Table 1.15

<i>Feedback from parents :</i>
Signature: <i>Date:</i>

Table 1.16

1.3.6 Assessment

LO 4
Measurement The learner will be able to use appropriate measuring units, instruments and formulae in a variety of contexts.
<i>We know this when the learner :</i>
4.1 solves ratio and rate problems involving time, distance and speed;
4.2 solves problems (including problems in contexts that may be used to develop awareness of human rights, social, economic, cultural and environmental issues) involving known geometric figures and solids in a range of measurement contexts by:
4.2.1 measuring precisely and selecting measuring instruments appropriate to the problem;
4.2.2 estimating and calculating with precision;
<i>continued on next page</i>

4.2.3 selecting and using appropriate formulae and measurements;
4.3 describes and illustrates the development of measuring instruments and conventions in different cultures throughout history;
4.4 uses the Theorem of Pythagoras to solve problems involving missing lengths in known geometric figures and solids.

Table 1.17

1.3.7 Memorandum

TEST

Where appropriate, give answers accurate to one decimal place.

1. Write the complete Theorem of Pythagoras down in words.
2. Calculate the hypotenuse of $\triangle ABC$ where $\angle A$ is a right angle and $b = 15$ mm and $c = 20$ mm.
3. $\triangle PQR$ has a right angle at R . $PR = QR$. Calculate the lengths of sides PR and QR if $QP = 15$ cm.
4. Is $\triangle DEF$ right-angled if $DF = 16$ cm, $DE = 14$ cm and $EF = 12$ cm?
5. What kind of triangle is $\triangle XYZ$ if $YZ = 24$ cm, $XY = 10$ cm and $XZ = 26$ cm? Give complete reasons.

TEST 3

1. In a right-angled triangle, the square on the hypotenuse is equal to the sum of the squares on the other two sides.

2. Hypotenuse = a . $a^2 = 15^2 + 20^2 = 225 + 400 = 625$ $a = 25$ Hypotenuse is 25 mm

3. $PR^2 + QR^2 = QP^2$ $2(PR)^2 = 15^2$ $2(PR)^2 = 225$ $PR^2 = 112,5$ $PR \approx 10,6$ cm

4. $LK = 16^2 = 256$

$RK = 14^2 + 12^2 = 196 + 144 = 340$

$LK \neq RK$, so $\triangle DEF$ is not right-angled.

5. $LK = 26^2 = 676$

$RK = 24^2 + 10^2 = 576 + 100 = 676$

$LK = RK$, so $\triangle XYZ$ is right-angled with Y the right angle.

6. Write the following roots in the simplest form:

6.1 $\sqrt{12}$

6.2 $\sqrt{50a^3b^5}$

6.3 $\sqrt[4]{64(a-1)^4b}$

INVESTIGATION

- If there is confusion about the a , b , c symbols, do draw a triangle as guidance while learners complete the table. Learners with poor measuring skills might need individual support, if they cannot get reasonable answers.
- Photocopy the squares so that they can be cut out and fitted.

2.1 This is the well-known “proof” of the Theorem of Pythagoras. This work is addressed again when working with similarity.

CLASS WORK

Encourage learners to get into the habit of making realistic sketches.

2.1.1

$EF = d$

$d^2 = 12^2 + 5^2 = 144 + 25 = 169 = 13^2$

$d = 13$

2.1.2 $XY = 4$

3.1.1 hypotenuse $^2 = 81 + 81 = 162$

hypotenuse $\approx 12,73$ cm

3.1.2 $PR^2 + RQ^2 = 2 (PR)^2$ – isosceles

$2(PR)^2 = 13,5^2$

$PR \approx 9,55$ cm

4. Because GH is the longest side, it has to be the hypotenuse – so $[U+FOD0]K$ is a right angle.

4.1.1 $LK = c^2 = 50^2 = 2500$ mm²

$RK = a^2 + b^2 = 30^2 + 40^2 = 2500$ mm²

$LK = RK$, triangle is right-angled; $[U+FOD0]C$ is the right angle.

4.1.2 $LK = 225$ cm² $RK = 64 + 169 = 233$ cm²

$LK \neq RK$ so triangle is not right-angled.

4.1.3 $LK = 242,11$ cm²

$RK = 121 + 121 = 242$ cm²

$LK \neq RK$ but almost!

$[U+FOD0]P$ is very close to 90° .

HOMEWORK ASSIGNMENT

1.1 $a = 12$ mm

1.2 $o = 10$ cm

2.1 No

2.2 Very close – $Z \approx 90^\circ$

CLASS WORK

1. $\sqrt{64} = 8$ does not fit the table.

c	$9 = 3^2$	$25 = 5^2$	$7^2 = 49$	$3^4 = 81$	$b \times b = b^2$	$64 = 2^6$	$a \times a \times a = a^3$
$\sqrt[3]{8} = 2$	$\sqrt{9} = 3$	$\sqrt{25} = 5$	$\sqrt{49} = 7$	$\sqrt[4]{81} = 3$	$b = \sqrt{b^2}$	$\sqrt[6]{64} = 2$	$\sqrt[5]{a^5} = a$

Table 1.18

2.1 $5a^2bc\sqrt{ab}$

2.2 $3x^3y^4\sqrt[3]{3}$

2.3 $4(a+b)$

ENRICHMENT ASSIGNMENT

- Group learners to check one another's work so that the whole class can decide on the answer.

1.4 How long is a piece of string?⁴

1.4.1 MATHEMATICS

1.4.2 Grade 9

1.4.3 NUMBERS

1.4.4 Module 4

1.4.5 HOW LONG IS A PIECE OF STRING?

CLASS WORK

1 Work in a group to answer the following questions:

1.1 How many metres is a thousand millimetres?

⁴This content is available online at <http://cnx.org/content/m31206/1.1/>.

1.2 Which units are the best for giving the following quantities? Some are difficult, and you may have to do some research and bring a better answer back later.

- 1.2.1 How tall you are.
- 1.2.2 The distance between our sun and the nearest star.
- 1.2.3 How long it will take to walk from Cape Town to Cairo.
- 1.2.4 The amount of milk you drink in a year.
- 1.2.5 The quantity of vitamin C one has to take in daily.
- 1.2.6 The temperature of a patient in a hospital in New York.
- 1.2.7 The area of Greenland.
- 1.2.8 The speed of a car on the open road.
- 1.2.9 The amount of wood a cabinetmaker orders at one time.
- 1.2.10 The total amount of money the government collects in taxes in a year.

end of CLASS WORK

PROJECT

The passing of time.

- We use watches and clocks to show how time passes.
- Do the following questions as a project. Don't make yourself guilty of plagiarism.

1 Explain the difference between *analogue* and *digital* clocks / watches.

2 List all the clocks in your home, and say whether each is analogue or digital.

3 Find at least one other method used to measure time or show the time – one that is not generally used in western culture. It can be something from earlier times, or something from another country. Try to find something about timekeeping in Africa. Explain clearly how it works.

- The project must be handed in on:

end of PROJECT

HOMEWORK ASSIGNMENT

1 Complete any remaining questions from the class assignment above.

2 What measuring instruments are used for the following measurements?

- 2.1 How tall you are.
- 2.2 The mass of a new-born baby.
- 2.3 The amount of milk you have to add, in a recipe.
- 2.4 The paint used for painting the outside of an ordinary house.
- 2.5 Humidity.
- 2.6 The speed of a moving car.
- 2.7 We have a very complicated way of determining leap years. Find out:
 - 2.7.1 Why we need to have leap years, and
 - 2.7.2 Which years will be leap years.

end of HOMEWORK ASSIGNMENT

Connecting with the world – ASSIGNMENT

- Choose one of these questions to do.

1 You've just discovered your granny's old recipe book. You remember some of her recipes, and you'd like to try them too. Unfortunately it uses old-fashioned units, which would be a lot of trouble to convert each time. Decide how you can make some kind of aid, like a table of graph or formula, to make conversions easier. The units that occur often are: the temperature of the oven is given in °F; the measures of mass are in ounces and pounds and the liquid measures are in pints.

2 Your father has just bought you a second-hand car, but it was imported from America and all the instruments use units you are unfamiliar with, and have difficulty making sense of. Decide how you can

make some kind of aid, like a table or graph or formulae that you can understand exactly what units like miles, gallons, miles per gallon (petrol consumption) mean in our units.

end of ASSIGNMENT

There have been several attempts to reform our Western calendar with its months of different lengths. But it isn't simple because the number of days in a year isn't a whole number (that is why we need that peculiar way of determining leap years). It would be an improvement if all the months were the same length, and if the year could consist of four equal quarters. Many people have attempted to change the calendar, but unfortunately all these very clever ideas failed because our old system is so ingrained in our culture. If you want to read more about this, you can try looking up "calendar" in the "Encyclopaedia Britannica". There's a lot of material about different calendar systems in various cultures. Try finding something about the "World Calendar".

CLASS WORK

- Starting with a line x cm long, one can make a square with four of these lines. Taking six of these squares, we can form a cube.

1 Write down the formulae for calculating (a) the area of a square and (b) the volume of a cube. Use x as the variable.

2 Now complete this table.

Length of line	Area of square	Volume of cube
x	x^2	x^3
7 cm
7,1 cm
6,9 cm
3 cm
3,3 cm
2,7 cm

Table 1.19

3 Say you had a *cube* that had to be measured by everyone in the class. All the side lengths of the faces are supposed to be 7cm, but not everyone measures very accurately. Then everybody uses his own measurements to calculate the volume of the cube. Will those measuring 1 mm *more* than 7 cm, make a bigger error in the volume than those measuring 1 mm *less* than 7 cm?

4 Now you have a *square* that has to be measured. All the side lengths are supposed to be 3 cm, but again your classmates get different measurements. Each again uses his own measurements, and calculates the area of the square. Will those measuring 3 mm *more* than 3 cm, make a bigger error in the area than those measuring 3 mm *less* than 3 cm?

THE FACE THAT LAUNCHED A THOUSAND SHIPS

- Question: What is measured in milliHelens?
- Answer: A milliHelen is the amount of beauty necessary to launch a single ship.
- Background: In Greek history, about three thousand years ago, Helen of Troy was abducted. Because she was so beautiful, her compatriots sailed out with a thousand ships to rescue her. So a mathematical joker, with reference to this tale, defined one Helen as the amount of beauty needed to launch a thousand ships.

Assessment

Measurement ω

<i>I can . . .</i>	ASs	[U+F04A]	[U+F04B]	[U+F04C]	Now I have to . . .
Recognise and use units of measurement	1.3.2				<
Name measuring instruments	4.3				
Do conversions	4.1; 4.2				
Measure accurately	1.5				>

Table 1.20

[U+F04A] *good* [U+F04B] *average* [U+F04C] *not so good*

For this learning unit I . . .			
Worked very hard	yes	no	
Neglected my work	yes	no	
Worked very little	yes	no	<i>Date:</i>

Table 1.21

Learner can . . .	ASs	1	2	3	4	Comments
Recognise and use units of measurement	1.3.2					
Name measuring instruments	4.3					
Do conversions	4.1; 4.2					
Measure accurately	1.5					

Table 1.22

Critical outcomes	1	2	3	4
Decodes, understands and solves problems				
Manages and uses information				
Accuracy				
Connects maths with the world				

Table 1.23

Educator:
Signature: <i>Date:</i>

Table 1.24

Feedback from parents:
Signature: <i>Date</i> :

Table 1.25

1.4.6 Assessment

Learning outcomes(LOs)
LO 1
Numbers, Operations and RelationshipsThe learner will be able to recognise, describe and represent numbers and their relationships, and to count, estimate, calculate and check with competence and confidence in solving problems.
Assessment standards(ASs)
<i>We know this when the learner :</i>
1.1 describes and illustrates the historical development of number systems in a variety of historical and cultural contexts (including local);
1.2 recognises, uses and represents rational numbers (including very small numbers written in scientific notation), moving flexibly between equivalent forms in appropriate contexts;
1.3 solves problems in context including contexts that may be used to build awareness of other learning areas, as well as human rights, social, economic and environmental issues such as:
1.3.1 financial (including profit and loss, budgets, accounts, loans, simple and compound interest, hire purchase, exchange rates, commission, rentals and banking);
1.3.2 measurements in Natural Sciences and Technology contexts;
1.4 solves problems that involve ratio, rate and proportion (direct and indirect);
1.5 estimates and calculates by selecting and using operations appropriate to solving problems and judging the reasonableness of results (including measurement problems that involve rational approximations of irrational numbers);
<i>continued on next page</i>

LO 4
MeasurementThe learner will be able to use appropriate measuring units, instruments and formulae in a variety of contexts.
<i>We know this when the learner :</i>
4.1 solves ratio and rate problems involving time, distance and speed;
4.2 solves problems (including problems in contexts that may be used to develop awareness of human rights, social, economic, cultural and environmental issues) involving known geometric figures and solids in a range of measurement contexts by:
4.2.1 measuring precisely and selecting measuring instruments appropriate to the problem;
4.2.2 estimating and calculating with precision;
4.2.3 selecting and using appropriate formulae and measurements;

Table 1.26

1.4.7 Memorandum

CLASS WORK

- 1.1 One
- 1.2.1 cm of m
- 1.2.2 light years
- 1.2.3 months
- 1.2.4 litres
- 1.2.5 milligrams
- 1.2.6 degrees Fahrenheit
- 1.2.7 km² or hectares
- 1.2.8 kilometres per hour
- 1.2.9 m³
- 1.2.10 Rand or millions or billions of rand

PROJECT

Encourage originality.

HOMEWORK ASSIGNMENT

- 2.1 ruler or measuring tape
- 2.2 scale
- 2.3 millilitres
- 2.4 litres
- 2.5 hygrometer
- 2.6 speedometer

ASSIGNMENT

- Accept any reasonably practical answers. This exercise can be addressed again when the learners have mastered graphs, formulae and tables. They should then be able to improve their answers.

CLASS WORK

- The intention of this exercise is to illustrate the consequences of inaccurate calculations. If time allows, the learners can be given photocopies of squares to measure. They can complete another table and compare answers.

1.5 Money Matters⁵

1.5.1 MATHEMATICS

1.5.2 Grade 9

1.5.3 NUMBERS

1.5.4 Module 5

1.5.5 MONEY MATTERS

Money matters

CLASS WORK

- Few people don't deal with money practically every day. We will look at a few important financial principles.

1 Someone who starts a business, does it so that he can earn money for buying food, paying his water and power accounts, and paying for his other needs. Making money out of a business means that you have to get more money in from the business than you pay out to keep the business running. So, he makes a *profit* when his *income* is bigger than his *expenses*. If the expenses are more than the income, then he shows a *loss*. Another way of putting it is to look at *gross income* and *net income*. Gross income is the same as income above, namely all the money the business receives. Net income is what is left after you have subtracted expenses from the income. When income is more than expenses, net income is *positive* (a profit), but when income is less than expenses, net income is *negative* – i.e. a loss.

1.1 Calculate the profit or loss of the following businesses:

1.1.1 Income: R 36 000, R1 250 and R9 500; Expenses: R49 000

1.1.2 Expenses: R120 560; R15 030 and R55 250; Expenses: R85 000; R95 000 and R63 550

1.1.3 Patsy sells dried fruit and sweets from her stall in a large shopping centre. In March she paid R150 for the stall and R850 for the floor area in the centre. She sold dried fruit to the value of R1 500. In March she paid R250 to an assistant who relieves her two afternoons. She also made R2 840 on the sweets she sold in March. In April her expenses for renting the stall stayed the same, but she had to pay R50 more for the floor space. Her purchases of dried fruit and sweets during March and April cost her a total of R5 500. Her assistant earned R280 in April. Patsy's phone account came to R860 for March and April. In April she sold dried fruit to the value of R1 370 and sweets for R2 550. Her packaging material for the two months came to R420. Did Patsy show a profit, or a loss for these two months? Show your calculations neatly.

2 All families have certain expenses that have to be paid. To do this, there must be an income – someone has to have a profitable business, or a job for which he or she receives a wage or a salary. To ensure that the important expenses are covered, most families *budget*. It is very easy. At the start of the month, you write down all the expected expenses for that month in order of importance. If all the critical expenses are less than the expected income for the month, then you have to decide what could be done with the rest: will a part of it be saved, or will all of it be spent? In this way you can avoid spending all your money on movies and parties, leaving nothing for the phone account! For example, the Jacobs family are expecting the following monthly expenses: R160 for municipal services, R240 for the telephone, R2 800 for groceries, R1 300 for a bond payment, R650 for the hire purchase payment on their car, R250 pocket money for the children, R150 school fees, R340 for petrol and R200 to save for a holiday. Mr and Mrs Jacobs together earn R8 200 per month.

- The family expects to need R6 090 for the above expenses, and this means that R2 110 is left over for other purchases.

⁵This content is available online at <<http://cnx.org/content/m31207/1.1/>>.

2.1 Make budgets for Anna, Louise and Maggie. They are in grade 9, and each receives pocket money every month: Anna gets R450, Louise gets R220 and Maggie gets R600. Out of this they have to pay for clothes, make-up, entertainment, sweets and cell phone charges. Work in groups of three – each one takes one of the girls and makes her budget. You have to decide what the budget will be like. When everyone has finished, all the learners who worked out Anna’s budget get together and form groups of 3, 4, 5 or 6. Do the same for Louise and Maggie. Compare your budgets and set up a new, better budget in each group. Hand in your answer.

3 Someone who needs more money than he has in the bank may decide to *borrow* the money from someone, or from a bank. He pays the person who gives him the *loan* (we call this payment *interest*) and this payment depends on many factors, like the size of the loan. The *interest rate* also depends on many things. The loan amount plus the interest is paid together either at the end of the loan period or in regular *repayments*. If Mr Botha borrows R8 500 for six months at an annual (yearly) interest rate of 15%, then after six months he has to pay back the R8 500 plus the interest which comes to R637,50 for six months. (For a year it would be 15% of R8 500.) He repays R9137,50.

3.1 Mrs Petersen bakes cakes for three shops. She needs a new oven. She has some money saved, and intends to borrow the other R3 500 she needs from a bank. She borrows the money at an interest rate of 13,5% per annum. What is the amount she’ll have to pay the bank at the end of the year?

4 People often budget money to be saved. This is a good way to get money together for future large expenditures. One can save for a holiday, to paint the house, to buy a new car and (very important) for retirement when there might not be a regular income anymore. The money is saved at a certain *interest rate*. This means that the bank you invest your money in will regularly make payments to you, depending on the rate of interest and the amount invested. This is called *simple* interest. If you don’t take the money, but keep on putting it back in the bank to enlarge the amount saved, the amount of interest keeps increasing. This is called *compound* interest.

For example: Mrs Van der Merwe saved while she was still employed, and on her retirement she had R150 000 in the bank. This she invested at an interest rate of 11% per annum. Every month the bank pays her one-twelfth of her annual interest. The interest comes to R16 500 per year, so she gets R1 375 per month.

- Janie’s rich uncle gave her R7 000 in a bank account (at a rate of 10%) when she turned six. Because the interest is put back into the account instead of being paid out, this is how her money grows:
 - After 1 year: $R7\ 000 + R700 = R7\ 700$ After 2 year: $R7\ 700 + R770 = R8\ 470$ After 3 year: $R8\ 470 + R847 = R9\ 317$ After 4 year: $R9\ 317 + R932 = R10\ 248$ (now Janie is ten years old)
 - On her 21st birthday she had a lovely nest egg in the bank – how much?
- On his first birthday, baby Kevin’s granny pays R500 into a bank account for him. On every subsequent birthday until he turns eighteen, she does the same. If we assume that the rate of interest stayed at 10% during these 17 years, and the interest is calculated at the end of each year on the money in the bank, and then added to the investment, we can calculate the value of his investment. On his second birthday this happens:
 - $R500$ (the first payment) + $R50$ (the interest) + $R500$ (the second payment) = $R1\ 050$ is the new amount in the bank.
 - A year later (three years old): $R1\ 050 + R105 + R500 = R1\ 655$ in the bank.
 - Then: $R1\ 655 + R165,50 + R500 = R2320,50$ et cetera: Complete the sum!

4.1 Mrs Van der Merwe, whose investments we looked at before, now inherits an amount of R95 000. She invests this, this time at an interest rate of 11,5% per annum. The interest is again paid out to her every month. Mrs Van der Merwe also receives a monthly pension of R3 100 from the pension fund of her previous employer. What is the total amount she receives every month?

5 Cars or furniture are often bought on hire purchase. This is a special type of loan for buying large items. It is convenient, but the interest rate is high, the goods have to be insured, a large deposit is required, the repayments are high and the full amount has to be paid within a certain period or the goods can be repossessed. This kind of loan is only given to people who have a fixed job, and then the maximum loan is determined by how much you earn to be sure that you can meet the repayments. An example is when someone wants to buy a new car. She has a steady job, and she has already saved R3 800. The salesman accepts her old car, which he values at R4 100, as part of the deposit. To buy a car costing R70 800,00 she will have to pay about R1 800 per month for 54 months before the car is her property.

5.1 What is the total amount of money she will have paid at the end of the 54 months?

5.2 Say she gets a loan from the bank at a rate of 18%, sells her old car at R4 000 and uses this and her savings to pay the R70 800 for the new car. She pays the bank loan off at a rate of R1 800 per month. What is the total cost of the car at the end of her loan repayments?

6 You have to have money in a foreign currency when you travel overseas. If you want to visit America, you have to exchange your rand for dollars. The amount of rand you have to pay for one dollar fluctuates from day to day. It has been as low as R1,50 in the past, and recently it was R13,80. This relationship between two currencies is called the *exchange rate*. An American tourist in South Africa paying about R35 for a hamburger, chips and cool drink, can calculate that the meal will cost him about \$3,50 if the exchange rate is R10,00 per dollar.

6.1 How many British pounds (£) will a visitor from England pay for the same meal, if the rand–pound exchange rate is 14,85?

end of CLASS WORK

QUALITY OF ANSWERS	poor ¹	unsatisfactory ²	satisfactory ³	excellent ⁴
1.1.1				
1.1.2				
1.1.3				
2.1				
3.1				
4.1				
5.1				
5.2				
6.1				

Table 1.27

HOMEWORK ASSIGNMENT

1 Find out what the turnover of a business is. Describe it and give an example.

2 Set up an improved budget for the Jacobs family, and decide how the rest of the income is to be spent. Think carefully about possible expenses not on the list in the question.

3 Someone borrows R12 000 at 11% per annum. After the first month she repays R900 month. In your opinion, how many months will it take her to repay the full amount? Show all your working neatly.

4 If you win R3 million in the Lotto and you invest it at 10,5% per annum, how much interest can you expect to receive every year? And monthly? And weekly? And daily? And how much do you still have in the bank? Round your answers to the nearest rand.

5 If you don't want to borrow money for a car, but you can save R1 500 per month (at an annual interest rate of 13,5%) until you have enough to pay R66 000 for the car of your choice; about how long will it take you?

6 You are on holiday in America, and you want to join a tour group to Disney World. They offer a six-day, all-inclusive tour package for \$1 740. The current exchange rate is R9,55 per dollar. Determine the rand amount a tour like this will set you back.

end of HOMEWORK ASSIGNMENT

Assessment

Financial calculations ω

<i>I can . . .</i>	ASs	[U+F04A]	[U+F04B]	[U+F04C]	Now I have to . . .
Calculate profit and loss	1.3.1				<
Understand budgets	1.3.1				
Calculate loans and interest	1.3.1				
Determine simple and compound interest of investments	1.3.1				
Understand hire purchase	1.3.1				
Use exchange rates	1.4				>

Table 1.28

[U+F04A] *good* [U+F04B] *average* [U+F04C] *not so good*

For this learning unit I . . .			
Worked very hard	yes	no	
Neglected my work	yes	no	
Worked very little	yes	no	<i>Date:</i>

Table 1.29

<i>Learner can . . .</i>	ASs	1	2	3	4	Comments
Calculate profit and loss	1.3.1					
Understand budgets	1.3.1					
Calculate loans and interest	1.3.1					
Determine simple and compound interest of investments	1.3.1					
Understand hire purchase	1.3.1					
Use exchange rates	1.4					
Critical outcomes	1	2	3	4		
Organises own portfolio						
Importance of financial matters						
Effective problem solving						
Creative problem solving						

Table 1.30

Educator:
Signature: <i>Date:</i>

Table 1.31

<i>Feedback from parents :</i>
Signature: <i>Date:</i>

Table 1.32

1.5.6 Assessment

Learning outcomes(LOs)
LO 1
Numbers, Operations and RelationshipsThe learner will be able to recognise, describe and represent numbers and their relationships, and to count, estimate, calculate and check with competence and confidence in solving problems.
<i>continued on next page</i>

Assessment standards(ASs)
<i>We know this when the learner :</i>
1.1 describes and illustrates the historical development of number systems in a variety of historical and cultural contexts (including local);
1.2 recognises, uses and represents rational numbers (including very small numbers written in scientific notation), moving flexibly between equivalent forms in appropriate contexts;
1.3 solves problems in context including contexts that may be used to build awareness of other learning areas, as well as human rights, social, economic and environmental issues such as:
1.3.1 financial (including profit and loss, budgets, accounts, loans, simple and compound interest, hire purchase, exchange rates, commission, rentals and banking);
1.3.2 measurements in Natural Sciences and Technology contexts;
1.4 solves problems that involve ratio, rate and proportion (direct and indirect);

Table 1.33

1.5.7 Memorandum

TEST

1. A toy shop:

Calculate the net income from the following information, and say whether it is a profit or a loss.

Expenses: Hiring shop: R1 450

Water and electricity: R380

Telephone: R675

Staff salaries: R7 530

Purchases of toys from wholesaler: R67 550

Packaging material: R1 040

Income from sales: R92 406

2. Joey borrows R780 for six months from his dad to fix his bicycle. His dad requires 8% interest per year. What is the sum of money Joey pays back after six months?

3. You receive a bequest of R12 000 from an aunt. But you have to wait five years until you are 19 before receiving it. In the meantime it is invested at 13,5% per annum compounded. What sum do you receive after five years?

4. The rand-euro exchange rate is 8,75. How many rand do you have to exchange if you need 11 500 euros for a holiday in Europe?

Memorandum

1. Net Income = Total Income – Total Expenses = R92 406 – R78 625 = R13781

and this is a profit.

2. For one year the interest comes to R62,40. For six months he owes his dad R811,20 in total.

3. After one year there is R13 620 in the bank.

After two years: R15458,70

After three years: R17 545, 62...

After four years: R19 914,28...

After five years: R22 602,71 rounded to the nearest cent

4. Rand = 8,75 × 11 500 = R100 625

- The teacher should adapt and extend this learning unit according to the background and experience of his learners, if they are not familiar with this environment.

CLASS WORK

$$1.1.1 \text{ Net income} = (36\,000 + 1\,250 + 9\,500) - 49\,000 = -2\,250 \text{ (R2 250 loss)}$$

$$1.1.2 (85\,000 + 95\,000 + 63\,550) - (120\,560 + 15\,030 + 55\,250) = 52\,710 \text{ rand profit}$$

$$1.1.3 \text{ Loss} = \text{R1 100}$$

2.1 There is no right or wrong answer – it is the process that matters.

$$3.1 \text{ R3 972,50}$$

4. The last example (Kevin) is actually more than compound interest. It illustrates the mechanism of an annuity – a popular saving mechanism. It can be taught as enrichment.

When learners learn about common factors, they will appreciate the pattern found in compound interest.

$$4.1 \text{ } 1\,375 + 3\,100 + 910,42 = \text{R5 385,42}$$

$$5.1 \text{ About R105 100}$$

$$5.2 \text{ About } r \text{ R85 000}$$

$$6.1 \text{ £2,36}$$

HOMEWORK ASSIGNMENT

1. Turnover is the total amount made from sales, before any deductions (gross amount).
2. Judge the process and not the answer.
3. 15 months (the amount in the 15th month is less).
4. Annually: R315 000; monthly: R26 250; weekly: R6 058; daily: R865
5. A little less than two years (in two years she saves nearly R70 000).
6. R16 617

Chapter 2

Term 2

2.1 The algebra of the four basic operations¹

MATHEMATICS

Grade 9

ALGEBRA AND GEOMETRY

Module 6

THE ALGEBRA OF THE FOUR BASIC OPERATIONS

Activity 1

To refresh understanding of conventions in algebra as applied to addition and subtraction

[LO 1.2, 1.6]

A We will first have a look at terms.

Remember, terms are separated by + or -. In each of the following, say how many terms there are:

1. $a + 5$
2. $2a^2$
3. $5a(a+1)$
4. $\frac{3a-1}{a^2} + 5a$

In the next exercise you must collect like terms to simplify the expression:

1. $5a + 2a$
2. $2a^2 + 3a - a^2$
3. $3x - 6 + x + 11$
4. $2a(a-1) - 2a^2$

B Adding expressions

Example:

Add $3x + 4$ by $x + 5$.

$(x + 5) + (3x + 4)$ Write, with brackets, as sum.

$x + 5 + 3x + 4$ Remove brackets, with care.

$4x + 9$ Collect like terms.

In this exercise, add the two given expressions:

1. $7a + 3$ and $a + 2$
2. $5x - 2$ and $6 - 3x$
3. $x + \frac{1}{2}$ and $4x - 3\frac{1}{2}$
4. $a^2 + 2a + 6$ and $a - 3 + a^2$
5. $4a^2 - a - 3$ and $1 + 3a - 5a^2$

C Subtracting expressions

Study the following examples very carefully:

¹This content is available online at <<http://cnx.org/content/m31212/1.1/>>.

Subtract $3x - 5$ from $7x + 2$.

$$(7x + 2) - (3x - 5)$$

Notice that $3x - 5$ comes second, after the minus.

$$7x + 2 - 3x + 5$$

The minus in front of the bracket makes a difference!

$$4x + 7$$

Collecting like terms.

Calculate $5a - 1$ minus $7a + 12$: $(5a - 1) - (7a + 12)$

$$5a - 1 - 7a - 12$$

$$-2a - 13$$

D Mixed problems

Do the following exercise (remember to simplify your answer as far as possible):

1. Add $2a - 1$ to $5a + 2$.
2. Find the sum of $6x + 5$ and $2 - 3x$.
3. What is $3a - 2a^2$ plus $a^2 - 6a$?
4. $(x^2 + x) + (x + x^2) = \dots$
5. Calculate $(3a - 5) - (a - 2)$.
6. Subtract $12a + 2$ from $1 + 7a$.
7. How much is $4x^2 + 4x$ less than $6x^2 - 13x$?
8. How much is $4x^2 + 4x$ more than $6x^2 - 13x$?
9. What is the difference between $8x + 3$ and $2x + 1$?

Use appropriate techniques to simplify the following expressions:

1. $x^2 + 5x^2 - 3x + 7x - 2 + 8$
2. $7a^2 - 12a + 2a^2 - 5 + a - 3$
3. $(a^2 - 4) + (5a + 3) + (7a^2 + 4a)$
4. $(2x - x^2) - (4x^2 - 12) - (3x - 5)$
5. $(x^2 + 5x^2 - 3x) + (7x - 2 + 8)$
6. $7a^2 - (12a + 2a^2 - 5) + a - 3$
7. $(a^2 - 4) + 5a + 3 + (7a^2 + 4a)$
8. $(2x - x^2) - 4x^2 - 12 - (3x - 5)$
9. $x^2 + 5x^2 - 3x + (7x - 2 + 8)$
10. $7a^2 - 12a + 2a^2 - (5 + a - 3)$
11. $a^2 - 4 + 5a + 3 + 7a^2 + 4a$
12. $(2x - x^2) - [(4x^2 - 12) - (3x - 5)]$

Here are the answers for the last 12 problems:

1. $6x^2 + 4x + 6$
2. $9a^2 - 11a - 8$
3. $8a^2 + 9a - 1$
4. $-5x^2 - x + 17$
5. $6x^2 + 4x + 6$
6. $5a^2 - 11a + 2$
7. $8a^2 + 9a - 1$
8. $-5x^2 - x - 7$
9. $6x^2 + 4x + 6$
10. $9a^2 - 13a - 2$
11. $8a^2 + 9a - 1$
12. $-5x^2 + 5x + 7$

Activity 2

To multiply certain polynomials by using brackets and the distributive principle

[LO 1.2, 1.6, 2.7]

A monomial has one term; a binomial has two terms; a trinomial has three terms.

A Multiplying monomials.

Brackets are often used.

Examples:

$$2a \times 5a = 10a^2$$

$$3a^3 \times 2a \times 4a^2 = 24 a^6$$

$$4ab \times 9a^2 \times (-2a) \times b = -36a^4b^2$$

$$a \times 2a \times 4 \times (3a^2)^3 = a \times 2a \times 4 \times 3a^2 \times 3a^2 \times 3a^2 = 126a^8$$

$$(2ab^2)^3 \times (a^2bc)^2 \times (2bc)^2 = (2ab^2) (2ab^2) (2ab^2) \times (a^2bc) (a^2bc) \times (2bc) (2bc) = 32a^7b^{10}c^4$$

Always check that your answer is in the simplest form.

Exercise:

1. $(3x) (5x^2)$

$(x^3) (-2x)$

$(2x)^2 (4)$

$(ax)^2 (bx^2) (cx^2)^2$

B Monomial \times binomial

Brackets are essential.

Examples:

$5(2a + 1)$ means multiply 5 by 2a as well as by 1. $5(2a + 1) = 10a + 5$

Make sure that you work correctly with your signs.

$$4a(2a + 1) = 8a + 4a$$

$$-5a(2a + 1) = -10a^2 - 5a$$

$$a^2(-3a^2 - 2a) = -3a^4 - 2a^3$$

$$-7a(2a - 3) = -14a^2 + 21a$$

Note: We have turned an expression in factors into an expression in terms. Another way of saying the same thing is: A product expression has been turned into a sum expression.

Exercise:

1. $3x(2x + 4)$

$x^2(5x - 2)$

$-4x(x^2 - 3x)$

$(3a + 3a^2)(3a)$

C Monomial \times trinomial

Examples:

$$5a(5 + 2a - a^2) = 25a + 10a^2 - 5a^3$$

$$-\frac{1}{2}(10x^5 + 2a^4 - 8a^3) = -5x^5 - a^4 + 4a^3$$

Exercise:

$3x(2x^2 - x + 2)$

$-ab^2(-bc + 3abc - a^2c)$

$12a\left(\frac{1}{4} + 2a + \frac{1}{2}a^2\right)$

Also try: 4. $4x(5 - 2x + 4x^2 - 3x^3 + x^4)$

D Binomial \times binomial

Each term of the first binomial must be multiplied by each term of the second binomial.

$$(3x + 2)(5x + 4) = (3x)(5x) + (3x)(4) + (2)(5x) + (2)(4) = 15x^2 + 12x + 10x + 8 = 15x^2 + 22x + 8$$

Always check that your answer has been simplified.

Here is a cat-face picture to help you remember how to multiply two binomials:

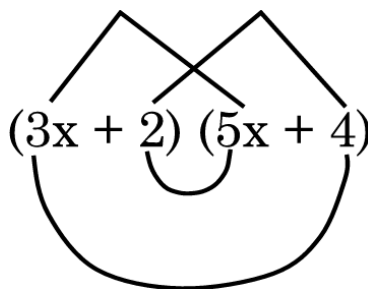

Figure 2.1

The left ear says multiply the first term of the first binomial with the first term of the second binomial. The chin says multiply the first term of the first binomial with the second term of the second binomial. The mouth says multiply the second term of the first binomial with the first term of the second binomial. The right ear says multiply the second term of the first binomial with the second term of the second binomial.

There are some very important patterns in the following exercise – think about them.

Exercise:

$$(a + b)(c + d)$$

$$(2a - 3b)(-c + 2d)$$

$$(a^2 + 2a)(b^2 - 3b)$$

$$(a + b)(a + b)$$

$$(x^2 + 2x)(x^2 + 2x)$$

$$(3x - 1)(3x - 1)$$

$$(a + b)(a - b)$$

$$(2y + 3)(2y - 3)$$

$$(2a^2 + 3b)(2a^2 - 3b)$$

$$(a + 2)(a + 3)$$

$$(5x^2 + 2x)(x^2 - x)$$

$$(-2a + 4b)(5a - 3b)$$

E Binomial \times polynomial

Example:

$$(2a + 3)(a^3 - 3a^2 + 2a - 3) = 2a^4 - 6a^3 + 4a^2 - 6a + 3a^3 - 9a^2 + 6a - 9 \\ = 2a^4 - 3a^3 - 5a^2 - 9 \text{ (simplified)}$$

Exercise:

$$(x^2 - 3x)(x^2 + 5x - 3)$$

$$(b + 1)(3b^2 - b + 11)$$

$$(a - 4)(5 + 2a - b + 2c)$$

$$(-a + 2)(a + b + c - 3d)$$

Activity 3

To find factors of certain algebraic expressions

[LO 1.6, 2.1, 2.7]

A Understanding what factors are

This table shows the factors of some monomials

Expression	Smallest factors
42	$2 \times 3 \times 7$
6ab	$2 \times 3 \times a \times b$
21a ² b	$3 \times 7 \times a \times a \times b$
(5abc) ²	$5 \times a \times b \times c \times c \times 5 \times a \times b \times c \times c$
-8y ⁴	$-2 \times 2 \times 2 \times y \times y \times y \times y$
(-8y ⁴) ²	$-2 \times 2 \times 2 \times y \times y \times y \times y \times -2 \times 2 \times 2 \times y \times y \times y \times y$

Table 2.1

You can write the factors in any order, but if you stick to the usual order your work will be easier. Two lists of factors in the table are not in the usual order – rewrite them in order.

B Finding common factors of binomials

Take the binomial $6ab + 3ac$.

The factors of $6ab$ are $2 \times 3 \times a \times b$ and the factors of $3ac$ are $3 \times a \times c$.

The factors that appear in both $6ab$ and $3ac$ are 3 and a – they are called common factors.

We can now use brackets to group the factors into the part that is common and the rest, as follows:

$$6ab = 3a \times 2b \text{ and } 3ac = 3a \times c$$

Now we can factorise $6ab + 3ac$. This is how to set it out:

$$6ab + 3ac = 3a(2b + c).$$

An expression in terms has been written as an expression in factors.

Or: A sum expression has been turned into a product expression.

Here are some more examples:

$$6x^2 + 12x = 3x(2x + 4)$$

$$5x^3 - 2x^2 = x^2(5x - 2)$$

$$-4x^3 + 12x^2 = -4x(x^2 - 3x)$$

$$9a^2 + 9a^3 = (3a + 3a^2)(3a)$$

Look back at the exercise in section B of the previous activity – did you recognise the problems?

C Finding common factors of polynomials

In exactly the same way we can find the common factors of more than two terms. Here are some examples:

Examples:

$$6x^3 - 3x^2 + 6x = 3x(2x^2 - x + 2)$$

$$ab^3c - 3a^2b^3c + a^3b^2c = ab^2c(b - 3ab + a^2)$$

$$3a + 24a^2 + 6a^3 = 3a(1 + 8a + 2a^2)$$

$$20x - 8x^2 + 16x^3 - 12x^4 + 4x^5 = 4x(5 - 2x + 4x^2 - 3x^3 + x^4)$$

You will notice that the terms remaining in the brackets don't have any more common factors left. This is because they have been fully factorised. You must always take out the highest common factor from all the terms.

Exercise:

Fully factorise the following expressions by taking out the highest common factor:

$$12abc + 24ac$$

$$15xy - 21y$$

$$3abc + 18ab^2c^3$$

$$8x^2y^2 - 2x$$

$$2a^2bc^2 + 4ab^2c - 7abc$$

$$12a(bc)^2 - 8(abc)^3 + 4(ab)^2c^3 - 20bc + 4a$$

Pair activity:

Did you notice that in each case the number of terms in the brackets after factorising was the same as the number of terms in the original expression?

Explain to your partner why you think this will always happen.

D Factorising difference of squares

In section D of the previous activity you had to multiply these three pairs of binomials:

$$(a + b)(a - b),$$

$$(2y + 3)(2y - 3) \text{ and}$$

$$(2a^2 + 3b)(2a^2 - 3b)$$

Here are the solutions:

$$(a + b)(a - b) = a^2 - b^2$$

$$(2y + 3)(2y - 3) = 4y^2 - 9$$

$$(2a^2 + 3b)(2a^2 - 3b) = 4a^4 - 9b^2$$

You will have noticed that the answers have a very special pattern: square minus square.

This is called a difference of squares and this is how it is factorised:

First-square minus second-square

$$= (\sqrt{\text{first-square}} + \sqrt{\text{second-square}})(\sqrt{\text{first-square}} - \sqrt{\text{second-square}})$$

Examples:

$$x^2 - 25 = (x + 5)(x - 5)$$

$$4 - b^2 = (2 + b)(2 - b)$$

$$9a^2 - 1 = (3a + 1)(3a - 1)$$

YOU HAVE TO BE VERY SURE OF THE MOST COMMON SQUARES AND THEIR ROOTS.

These are a few important ones – you must add to this list.

$$2^2 = 4 \quad 3^2 = 9 \quad (a^2)^2 = a^4$$

$$(a^3)^2 = a^6$$

$$\left(\frac{1}{2}\right)^2 = \frac{1}{4} \quad 12 = 1$$

Exercise:

Factorise fully:

1. $a^2 - b^2$

$4y^2 - 9$

$4a^4 - 9b^2$

$1 - x^2$

$25 - a^6$

$a^8 - \frac{1}{4}$

$4a^2b^2 - 81$

$0,25 - x^2y^6$

9. $2a^2 - 2b^2$ (take care!)

E Combining common factors with differences of squares

As you saw in the last exercise (number 9), it is essential to check for common factors first and then to factorise the bracketed polynomial if possible.

Another example:

Factorise $12ax^2 - 3ay^2$

First recognise that there is a common factor of $3a$, before saying that this can't be a difference of squares.

$$12ax^2 - 3ay^2 = 3a(4x^2 - y^2) \text{ Now we recognise } 4x^2 - y^2 \text{ as the difference of two squares.}$$

$$12ax^2 - 3ay^2 = 3a(4x^2 - y^2) = 3a(2x + y)(2x - y).$$

Exercise:

Factorise completely:

1. $ax^2 - ay^4$

2. $a^3 - ab^2$

3. $0,5a^2x - 4,5b^2x$

4. $a^5b^3c - abc$

F Successive differences of squares

Try factorising this binomial completely by keeping your eyes open: $a^4 - b^4$

Now do this exercise – as usual factorise as far as possible.

1. $x^6 - 64$
2. $1 - m^8$
3. $3a^4 - 24b^8$
4. $x - x^9$

G Factorising trinomials

If you study the answers to the following four problems (they are from a previous activity), you will notice that the answers, after simplifying, sometimes have two terms, sometimes three terms and sometimes four terms. Discuss what you see happening (with a partner) and decide why they are different.

1. $(a + b)(a - b) = a^2 - ab + ab - b^2 = a^2 - b^2$ (when simplified)
2. $(a + 2)(a + 3) = a^2 + 3a + 2a + 6 = a^2 + 5a + 6$
3. $(a + b)(a + b) = a \times a + ab + ba + b \times b = a^2 + ab + ab + b^2 = a^2 + 2ab + b^2$ (in the simplest form)
4. $(a + b)(c + d) = ac + ad + bc + bd$ (and this answer can not be simplified)

The answer to the type of problem represented by number 1 above is a difference of squares.

The answers to numbers 2 and 3 are trinomials, and we will now see how to factorise them

The first fact that you must always remember is that not all trinomials can be factorised.

Work backwards through problem 2:

$$a^2 + 5a + 6 = a^2 + 3a + 2a + 6 = (a + 2)(a + 3).$$

So that you can see clearly where the a^2 came from, and the $5a$ and the 6 .

Now try to factorise $a^2 + 7a + 12 = (\dots\dots\dots) (\dots\dots\dots)$ by filling in two correct binomials in the brackets.

You can check your answer by multiplying the binomials in your answer as you were taught in activity 2. Keep trying and checking your answer until you have it right. Do the same in the following three exercises:

Match up the two columns:

- | | |
|-------------------|---------------------|
| A. $a^2 - 5a - 6$ | 1. $(x + 2)(x + 3)$ |
| B. $a^2 - a - 6$ | 2. $(x - 2)(x + 3)$ |
| C. $a^2 - 5a + 6$ | 3. $(x + 1)(x - 6)$ |
| D. $a^2 + 7a + 6$ | 4. $(x - 2)(x - 3)$ |
| E. $a^2 + 5a + 6$ | 5. $(x + 1)(x + 6)$ |
| F. $a^2 + 5a - 6$ | 6. $(x - 1)(x + 6)$ |
| G. $a^2 + a - 6$ | 7. $(x + 2)(x - 3)$ |
| H. $a^2 - 7a + 6$ | 8. $(x - 1)(x - 6)$ |

Now factorise the following trinomials by using the same techniques you have just learnt. The last two are more difficult than the first four!

- $a^2 + 3a + 2$
- $a^2 + a - 12$
- $a^2 - 4a + 3$
- $a^2 - 9a + 20$
- $a^2 + ab - 12b^2$
- $2a^2 - 18a + 40$

Problem	One factor correct	Both factors correct	Answer checked by multiplication
<i>continued on next page</i>			

	1	2	3
1			
2			
3			

Table 2.2

4			
5			
6			

Table 2.3

Finally, in groups of 3, 4 or 5, work out exactly how one should go about factorising these trinomials, and write down a strategy that will get you to the answer accurately and quickly.

Activity 4

To use factorising in simplifying fractions, and in multiplying, dividing and adding fractions

[LO 1.2, 1.6, 2.9]

A. Simplifying algebraic fractions

Two of the following four fractions can be simplified and the others can't. Which is which?

$$\frac{2+a}{2-a}$$

$$\frac{3(a+b)}{a+b}$$

$$\frac{4+x}{x+4}$$

$$\frac{a(b-c)}{2(b+c)} \quad (2.1)$$

As you have seen in the previous activity, factorising is a lot of trouble. So, why do we do it?

The following expression cannot be simplified as it is $\frac{6a^2b-6b}{2a-2}$ because we are not allowed to cancel terms. If we can change the sum expressions into product expressions (by factorising) then we will be able to cancel the factors, and simplify.

$$6a^2b - 6b = 6b(a^2 - 1) = 6b(a + 1)(a - 1) \text{ and } 2a - 2 = 2(a - 1)$$

So, the reason we factorise is that it allows us to simplify expressions better.

$$\text{Now: } \frac{6a^2b-6b}{2a-2} = \frac{6b(a+1)(a-1)}{2(a-1)} = \frac{3b(a+1)}{1} = 3b(a+1)$$

It is very important that you factorise completely.

Exercise:

Factorise the numerator and denominator, cancel factors and write in the simplest form:

$$1 \frac{12a+6b}{2a+b}$$

$$2 \frac{x^2-9}{x+3}$$

$$3 \frac{2(a+1)(a-1)}{6(a+1)^2}$$

$$4 \frac{5a^2-5}{5a+5}$$

B. Multiplying and dividing fractions

Our normal rules for multiplication and division of fractions are still the same. Study the following examples, taking special note of the factorising and cancelling.

$$\frac{4x^3y}{6y^2} \div \frac{xy}{3x^2} \times \frac{2xy^2}{3x} = \frac{4x^3y}{6y^2} \times \frac{3x^2}{xy} \times \frac{2xy^2}{3x} = \frac{4x^4}{3}$$

$$\frac{a^2-9}{2} \times \frac{1}{4a^2-12a} = \frac{(a+3)(a-3)}{2} \times \frac{1}{4a(a-3)} = \frac{(a+3)}{8a}$$

$$\frac{3a+6}{5} \div \frac{a^2-4}{10} = \frac{3a+6}{5} \times \frac{10}{a^2-4} = \frac{3(a+2)}{5} \times \frac{10}{(a+2)(a-2)} = \frac{6}{a-2}$$

Exercise:

Simplify:

- $\frac{2ab^2}{b^3c} \times \frac{9ac^2}{4b} \div \frac{3ac}{2b^2}$
- $\frac{2(a+1)(a-2)^2}{(a-2)^3(a+3)} \times \frac{9(a+1)(a+3)^2}{4(a-2)} \div \frac{3(a+1)(a+3)}{2(a-2)^2}$
- $\frac{4a^2+8a}{2b+4} \times \frac{3(b^2+2)}{3a^2+6a}$
- $\frac{x^2-1}{5x-5} \div \frac{(x+1)^2}{15x+15}$
- $\frac{7x}{3xy} \div \frac{3x+6}{5x^2y} \div \frac{5x-10}{3x^2-12}$
- $\frac{\frac{5x^2+5x}{x^2-1}}{\frac{x^2-x}{5x+5}}$ (here we have a fraction divided by a fraction – first rewrite it like number 4)

C. Adding fractions

You already know quite well that adding and subtracting fractions is a lot more difficult than multiplying and dividing them. The reason is that we can only add and subtract the same kind of fractions, namely fractions with identical denominators. If the denominators are different, find the lowest common multiple of the denominators (LCD), rewrite all the terms with this as denominator, and then simplify by gathering like terms together. Finally, the answer has to be simplified by cancelling factors occurring in both numerator and denominator. Here are some examples – all the steps have been shown:

Simplify:

- $\frac{5abx}{2cx} + \frac{4ac}{3x} + \frac{cx}{2a}$ (LCD = 6acx)
 $\left(\frac{5abx}{2cx} \times \frac{3a}{3a}\right) + \left(\frac{4ac}{3x} \times \frac{2ac}{2ac}\right) + \left(\frac{cx}{2a} \times \frac{3cx}{3cx}\right) = \frac{15a^2bx}{6acx} + \frac{8a^2c^2}{6acx} + \frac{3c^2x^2}{6acx} = \frac{15a^2bx+8a^2c^2+3c^2x^2}{6acx}$
- $\frac{a+b}{2} + \frac{b+c}{3} - \frac{a+c}{6}$ (LCD = 6) Take careful note of how the signs are handled below!
 $\frac{3(a+b)}{6} + \frac{2(b+c)}{6} - \frac{a+c}{6} = \frac{3(a+b)+2(b+c)-(a+c)}{6} = \frac{3a+3b+2b+2c-a-c}{6} = \frac{2a+5b+c}{6}$

- $\frac{a+3}{a^2-4} + \frac{1}{3a+6} + \frac{2}{5a-10}$

To find Lowest Common Denominator first factorise denominators!

$$\frac{a+3}{(a+2)(a-2)} + \frac{1}{3(a+2)} + \frac{2}{5(a-2)}$$

Do you see that the LCD is $3 \times 5 \times (a+2)(a-2)$?

$$\left(\frac{a+3}{(a+2)(a-2)} \times \frac{15}{15}\right) + \left(\frac{1}{3(a+2)} \times \frac{5(a-2)}{5(a-2)}\right) + \left(\frac{2}{5(a-2)} \times \frac{3(a+2)}{3(a+2)}\right)$$

$$= \frac{15(a+3)+5(a-2)+6(a+2)}{15(a+2)(a-2)} = \frac{15a+45+5a-10+6a+12}{15(a+2)(a-2)} = \frac{26a+47}{15(a+2)(a-2)}$$

Exercise:

Simplify the following expressions by using factorising:

- $\frac{a}{x^2} - \frac{a}{x} + \frac{5a}{2x}$
- $\frac{1}{3} + \frac{2x+1}{2x} - \frac{x-1}{3x}$
- $\frac{4a-4b}{2a^2-2b^2} - \frac{2a-2b}{3}$
- $\frac{1}{2}(a-2) + \frac{2}{3}(a+1) - \frac{3}{4}(a-3)$

Assessment: Assess the 4 problems in the exercise above.

Here is one final trick. We could simplify $\frac{2(x-1)}{3(x+3)} \times \frac{9(x+3)}{(1-x)}$ better if $(1-x)$ had been: $(x-1)$.

So, we make the change we want by changing the sign of the whole binomial as well:

$(1-x) = -(x-1)$ because $-(x-1) = -x + 1$, which is $1-x$. Finish the problem yourself.

Assessment

Learning outcomes (LOs)

continued on next page

LO 1
Numbers, Operations and RelationshipsThe learner will be able to recognise, describe and represent numbers and their relationships, and to count, estimate, calculate and check with competence and confidence in solving problems.
Assessment standards(ASs)
We know this when the learner:
1.1 describes and illustrates the historical development of number systems in a variety of historical and cultural contexts (including local);
1.2 recognises, uses and represent rational numbers (including very small numbers written in scientific notation), moving flexibly between equivalent forms in appropriate contexts;
1.3 solves problems in context, including contexts that may be used to build awareness of other Learning Areas, as well as human rights, social, economic and environmental issues such as:
1.3.1 financial (including profit and loss, budgets, accounts, loans, simple and compound interest, hire purchase, exchange rates, commission, rentals and banking);
1.3.2 measurements in Natural Sciences and Technology contexts;
1.4 solves problems that involve ratio, rate and proportion (direct and indirect);

Table 2.4

1.5 estimates and calculates by selecting and using operations appropriate to solving problems and judging the reasonableness of results (including measurement problems that involve rational approximations of irrational numbers);	
1.6 uses a range of techniques and tools (including technology) to perform calculations efficiently and to the required degree of accuracy, including the following laws and meanings of exponents (the expectation being that learners should be able to use these laws and meanings in calculations only):	
<i>continued on next page</i>	

1.6.1 $x^n \times x^m = x^{n+m}$	
1.6.2 $x^n \div x^m = x^{n-m}$	
1.6.3 $x^0 = 1$	
1.6.4 $x^{-n} = \frac{1}{x^n}$	
1.7 recognises, describes and uses the properties of rational numbers.	
LO 2	
Patterns, Functions and Algebra The learner will be able to recognise, describe and represent patterns and relationships, as well as to solve problems using algebraic language and skills.	
We know this when the learner:	
2.1 investigates, in different ways, a variety of numeric and geometric patterns and relationships by representing and generalising them, and by explaining and justifying the rules that generate them (including patterns found in natural and cultural forms and patterns of the learner's own creation);	
2.7 uses the distributive law and manipulative skills developed in Grade 8 to:	
find the product of two binomials;	
factorise algebraic expressions (limited to common factors and difference of squares).	
2.8 uses the laws of exponents to simplify expressions and solve equations;	
2.9 uses factorisation to simplify algebraic expressions and solve equations.	

Table 2.5

Memorandum

TEST 1

1. Simplify the following expressions by collecting like terms:

1.1 $3a^2 + 3a^2 - 6a + 3a - 4 + 1$

1.2 $2y^2 - 1y + 2y^2 - 6 + 2y - 9$

1.3 $8x^2 - (5x + 12x^2 - 1) + x - 4$

1.4 $(3a - a^2) - [(2a^2 - 11) - (5a - 3)]$

2. Give the answers to the following problems in the simplest form:

2.1 Add $3x^2 + 5x - 1$ to $x^2 - 3x$

2.2 Find the sum of $2a + 3b - 5$ and $3 + 2b - 7a$

2.3 Subtract $6a + 7$ from $5a^2 + 2a + 2$

2.4 How much is $3a - 8b + 3$ less than $a + b + 2$?

3. Simplify by multiplication, leaving your answer in the simplest form:

3.1 $(3x^2) \times (2x^3)$

3.2 $(abc) (a^2c) (2b^2)$

3.3 $abc(a^2c + 2b^2)$

3.4 $-3a(2a^2 - 5a)$

3.5 $(a - 2b) (a + 2b)$

3.6 $(3 - x^2) (2x^2 + 5)$

3.7 $(x - 5y)^2$

3.8 $(2 - b) (3a + c)$

TEST 1 – Memorandum

- 1.1 $6a^2 - 3a - 3$
 1.2 $4y^2 + y - 15$
 1.3 $-4x^2 - 4x - 3$
 1.4 $-3a^2 + 8a + 8$
 2.1 $4x^2 + 2x - 1$
 2.2 $-5a + 5b - 2$
 2.3 $5a^2 - 4a - 5$
 2.4 $-2a + 9b - 1$
 3.1 $6x^5$
 3.2 $2a^3b^3c^2$
 3.3 $a^3bc^2 + 2ab^3c$
 3.4 $-6a^3 + 15a^2$
 3.5 $a^2 - 4b^2$
 3.6 $-2x^4 + x^2 + 15$
 3.7 $x^2 - 10xy + 25y^2$
 3.8 $6a + 2c - 3ab - bc$

TEST 2

1. Find the Highest Common Factor of these three expressions: $6a^2c^2$ and $2ac^2$ and $10ab^2c^3$.
 2. Completely factorise these expressions by finding common factors:
 2.1 $12a^3 + 3a^4$
 2.2 $-5xy - 15x^2y^2 - 20y$
 2.3 $6a^2c^2 - 2ac^2 + 10ab^2c^3$
 3. Factorise these differences of squares completely:
 3.1 $a^2 - 4$
 3.2 $\frac{1}{9}a^2 - 9b^2$
 3.3 $x^4 - 16y^4$
 3.4 $1 - a^4b^4$
 4. Factorise these expressions as far as possible:
 4.1 $3x^2 - 27$
 4.2 $2a - 8ab^2$
 4.3 $a^2 - 5a - 6$
 4.4 $a^2 + 7a + 6$
 5. Simplify the following fractions by making use of factorising:
 5.1 $\frac{3a^2-3}{6a+6}$
 5.2 $\frac{6x^2y-6y}{2x-2}$
 5.3 $\frac{a^2-9}{2} \times \frac{1}{4a^2-12a}$
 5.4 $\frac{3x+6}{5} \div \frac{x^2-4}{15}$
 5.5 $\frac{abx}{2cx} + \frac{2ac}{3x} + \frac{3cx}{2a}$
 5.6 $\frac{2a}{x^2} - \frac{3a}{x} + \frac{a}{2x}$
 5.7 $\frac{4a-4b}{2a^2-2b^2} - \frac{3}{2a-2b}$
 5.8 $\frac{2}{3}(a+2) + \frac{1}{3}(a-1) - \frac{1}{4}(a-5)$

TEST 2 – Memorandum

1. $2ac^2$
 2.1 $3a^3(4 + a^2)$
 2.2 $-5y(x + 3x^2y + 4)$
 2.3 $2ac^2(3a - 1 + 5b^2c)$
 3.1 $(a + 2)(a - 2)$
 3.2 $(\frac{1}{3}a + 3b)(\frac{1}{3}a - 3b)$
 3.3 $(x^2 + 4y^2)(x + 2y)(x - 2y)$

3.4 $(1 + a^2b^2)(1 + ab)(1 - ab)$

4.1 $3(x + 3)(x - 3)$

4.2 $2a(1 + 4b)(1 - 4b)$

4.3 $(a + 1)(a - 6)$

4.4 $(a + 1)(a + 6)$

5.1 $\frac{a-1}{2}$

5.2 $3y(x + 1)$

5.3 $\frac{a+3}{8}$

5.4 $\frac{8a}{x-2}$

5.5 $\frac{3a^2bx+4a^2c^2+9c^2x^2}{6acx}$

5.6 $\frac{4a-5ax}{2x^2}$

5.7 $\frac{a-7b}{2(a+b)(a-b)}$

5.8 $\frac{3a+9}{4}$

2.2 Geometry of lines and triangles²

2.2.1 MATHEMATICS

2.2.2 Grade 9

2.2.3 ALGEBRA AND GEOMETRY

2.2.4 Module 8

2.2.5 GEOMETRY OF LINES AND TRIANGLES

Activity 1

To learn conventions of naming sides and angles in triangles

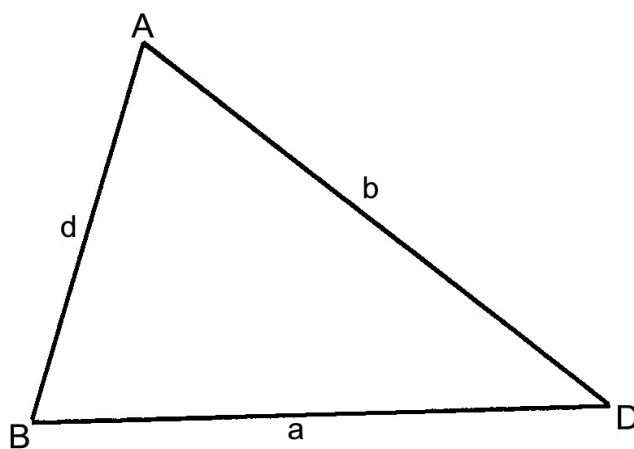

Figure 2.2

²This content is available online at <http://cnx.org/content/m31227/1.1/>.

- Refer to the triangle alongside to understand the terms.
- The three *sides* of the triangle are called AB, AD and BD.
- We often name a side in a triangle by using the small letter of the name of the opposite corner. The corners (vertices) of the triangle are named by using capital letters.
- When $\sphericalangle A$ or \hat{A} is used, it refers to the *angle* made by side BA and side AD.
- For the angle one can also say $\sphericalangle BAD$ or $\hat{B A D}$.
- But if I say $A=38^\circ$, it is clear what I mean.
- We refer to triangle ABD or $\triangle ABD$, writing the letters in alphabetical order.

Exercise:

To show that you understand the naming conventions, draw the following triangle in the space to the right:

Draw $\triangle QRT$ with $q=4\text{cm}$, $\sphericalangle T=65^\circ$ and $QT=5,5\text{cm}$.

You should notice that you don't need to be told

the length of t , nor the sizes of \hat{Q} or \hat{R} . First draw a rough sketch and fill the details in on that sketch to help you plan your drawing.

Assignment:

You should already know that triangles are classified according to their shape. Make an A4-sized poster for your own use, clearly showing the characteristics of the following types of triangle: equilateral, right-angled, isosceles and scalene. Name the vertices and sides according to the conventions above. You must work as accurately and neatly as you can.

Measure the sides and the angles of your triangles and fill these measurements in on your poster.

Activity 2

To develop the principle of congruence in triangles

[LO 4.4, 3.3, 3.5]

- In the previous exercise you drew $\triangle QTR$ from specifications given to you. Ask the other learners who did this exercise to show you their drawings, and check whether their triangles agree perfectly with the sizes given in the question. Measure the side and the two angles not specified, to see whether they also agree with yours.
 - You should find that all triangles drawn by anybody according to the instructions, are always identical. In fact, it is impossible to draw that triangle so that it is different! Write down, with a partner, why you think this is the case.
 - Here are more descriptions of triangles. See whether the same happens with them – in other words, that it is impossible to draw different triangles that fit the same description. Again, write down your view of each situation. The last one is quite difficult to draw – try it!
- Draw $\triangle AGE$ with $a=4\text{cm}$, $\sphericalangle E=90^\circ$ and $AG=5\text{cm}$.
 - Draw $\triangle NOH$ with $HN=4\text{cm}$, $\sphericalangle H=56^\circ$ and $\sphericalangle O=72^\circ$.
 - Draw $\triangle BAT$ with $\sphericalangle B=48^\circ$, $\sphericalangle T=65^\circ$ and $\sphericalangle A=67^\circ$.
 - Draw $\triangle MOD$ with $m=5,5\text{cm}$, $\sphericalangle O=65^\circ$ and $DM=4\text{cm}$.
 - Draw $\triangle AMP$ with $a=4,2\text{cm}$, $m=5\text{cm}$ and $p=5,6\text{cm}$.
 - In each of the above triangles, only three of the six sizes (three sides and three angles) were specified in the question. And sometimes that was enough to ensure that everyone drew identical triangles. But in $\triangle BAT$ and $\triangle MOD$ the three items were not enough to ensure identical triangles from everyone.
 - So, when is it enough? Maybe you have already discovered the secrets:

Δ QRT: Two sides and the angle between them were specified.

Δ AGE: A right-angle, the hypotenuse and another side were specified.

Δ NOH: One side and two angles were specified.

Δ AMP: Three sides were specified.

Δ BAT: Three angles were specified, but nothing said how big the triangle could be!

Δ MOD: Two sides and the angle not between the two sides were specified, so that it could happen that some learners drew a short OM side and others drew a longer OM side; because nothing was said how long OM had to be!

- When two triangles are identical in every way – size and shape – then we call them *congruent*. This means that if you cut one out, it can be placed exactly on top of the other. As you will see later, the word can be used for other identical shapes as well, but for now we will concern ourselves only with triangles.
- From the drawing exercise you saw that there are four different ways to ensure that triangles are congruent. Here they are, with helpful sketches:

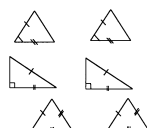

Figure 2.3



Figure 2.4

Case 1: Two triangles with two sides and the *included* angle equal, will be congruent.

Case 2: Two right-angled triangles with the hypotenuse and another side equal, will be congruent.

Case 3: Two triangles with three sides equal will be congruent.

Case 4: Two triangles with two angles and corresponding sides equal, will be congruent. This means that the equal sides must be opposite corresponding angles.

Investigation:

The next exercise shows 15 triangles, named A to O. They are all mixed-up and in strange orientations. Work in a group of 4 or 5 to decide whether any of them are congruent. Group the names of those that are congruent, with explanations and reasons. This is not a straight-forward exercise; it is much more like a puzzle. You will have to use all your experience, common-sense and logic. The sizes are not correct, so that you have to use the information *given*, and notmeasure anything.

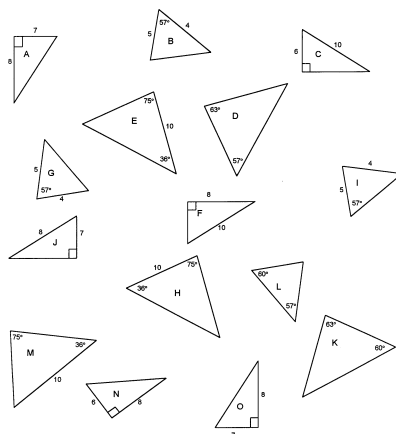

Figure 2.5

Activity 3

To apply the four cases of congruence in problems

[LO 4.4, 3.3, 3.4]

- When you have shown that two triangles are congruent (as you had to do in the previous exercise) you have to do a number of things: First decide which case of congruence will apply. Then say why each of the three items is equal. Then write your conclusions down in the proper order. Here is an example of how it can be done. We use the symbol [U+FOBA] to show congruence. So we can see that, if we know that three very special things are equal, we know that everything else must be equal too!

Prove that $\triangle ABC$ and $\triangle DEF$ are congruent.

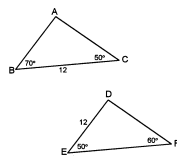

Figure 2.6

-
1. $\overset{\ominus}{A} = 60^\circ$ because the angles of a triangle add up to 180°
Therefore, $\overset{\ominus}{A} = \overset{\ominus}{F}$ because both are 60°
 2. $\overset{\ominus}{C} = \overset{\ominus}{E}$ because both are 50°
 3. $BC = DE$ because they are both 12 units, and they lie opposite equal angles. We have two equal angles and a corresponding equal side in each of the two triangles.
 4. So we write: $\triangle ABC$ [U+FOBA] $\triangle DEF$ (AAS) which means: $\triangle ABC$ is congruent to $\triangle DEF$ because two angles and a corresponding side are equal. This means that all other things must be equal too.
From the exercise in the previous section, do at least three congruencies in this way.

Exercise:

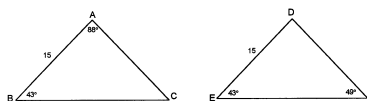

Figure 2.7

Prove that the two triangles in each of the following problems are congruent.

1.

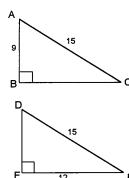

Figure 2.8

3.

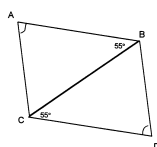

Figure 2.9

Activity 4

To understand the principle of similarity in triangles

[LO 1.2, 1.4, 3.5]

- In a previous exercise you were asked to draw $\triangle BAT$ with $\angle B = 48^\circ$, $\angle T = 65^\circ$ and $\angle A = 67^\circ$. As you noticed, it was possible to draw many triangles according to these specifications, but they were not congruent. This is because nothing specified the size of the triangle, so some were bigger and some were smaller.
- Work in groups of four or five. Measure the sides of your triangle. Each uses his own $\triangle BAT$ to complete his row in the table below. Where you divide, give your answer rounded to one decimal place.

Learner	AB	AT	BT	BT [U+FOB8] AT	AB [U+FOB8] AT	BT [U+FOB8] AB

Table 2.6

- In the next exercise you must draw two isosceles triangles with angles 80° , 50° and 50° . Make the one triangle about two or three times as big as the other. Work very accurately.
- Call the small triangle DEF ($\angle F = 80^\circ$) and the big one OPT ($\angle T = 80^\circ$). Measure all the sides and complete the table from your measurements.

OP	PT	OT	DE	EF	DF	OP [U+FOB8] DE	PT [U+FOB8] EF	OT [U+FOB8] DF

Table 2.7

Assignment:

- Study the two tables (especially the last three columns of both tables). What do you notice?
- Write a very clear explanation of why these calculations work out the way they do.
- These triangles are not congruent, as their sizes are different, even if their angles agree. When two triangles have equal angles but different sizes, we call them *similar*.
- The sign is $\triangle DEF$, so that $\triangle DEF \sim \triangle OPT$ from the last table.
- All triangles with three angles equal are automatically *similar*. If they have the same size, then they are *congruent* as well.
- Similar triangles have sides that are in the same proportion. This is what we see from the two tables we completed. The fractions that were calculated from the side lengths give us the ratios between sides.
- From the first table we see that the ratios between the sides of similar triangles are the same. From the second table we see that the ratios between corresponding sides of two similar triangles are the same. This ratio is called the *proportional constant* for the two triangles.
- We know two things from the facts we have learned about similar triangles:
 - Firstly, if we have two triangles with equal angles (*equiangular triangles*), then we know they are similar and therefore the sides must be in proportion.
 - Secondly, when we have triangles with sides in proportion, we know they must have equal angles because they must be similar.

Example:

What can you say about the two triangles below? Calculate the values of x and y .



Figure 2.10

To find out whether the triangles are similar, we must find either equal angles or sides in proportion. In this problem, we can say the angles are equal but we cannot say the sides are in proportion. In other problems, it may be the other way around. .

We set it out this way:

1. $\angle A = 65^\circ$ because the angles of $\triangle ABC$ add up to 180°
 2. The triangles have equal angles, therefore they are similar, so $\triangle ABC \sim \triangle DEF$ (equal angles)
 3. This means that the sides must be in proportion.
 4. Find out what the proportional constant is. $AC = 16$ and $DF = 8$.
- These two sides are both opposite the 80° angles, so that they are corresponding angles.
 - The proportional constant is $\frac{16}{8} = 2$. If we *multiply* the a side of the small triangle by 2, we get the length of the corresponding side in the large triangle. If you *divide* a side of the large triangle by 2 then you get the length of the corresponding side in the small triangle.
5. Now the value of x can be calculated by dividing 9 by 2. $x = 4,5$
 6. And $y = 2 \times 5,5 = 11$.

Exercise:

Calculate the values of sides PR and XY in the following triangles.



Figure 2.11

Example:

Find all the missing angles in these two triangles, if possible.

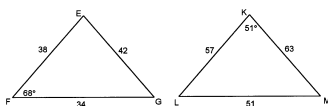

Figure 2.12

1. The sides are in proportion: $42 \times 1,5 = 63$, $38 \times 1,5 = 57$ and $34 \times 1,5 = 51$
 2. This means that the triangles are similar: $\triangle EFG \sim \triangle KLM$ (sides in proportion)
 3. So, corresponding angles are equal: $\angle L = 68^\circ$ (corresponds to $\angle F$)
 $\angle E = 51^\circ$ (corresponds to $\angle K$)
 $\angle G = \angle M = 61^\circ$ (sum of the angles of a triangle)
- Exercise:
 Find all the missing angles in these triangles:

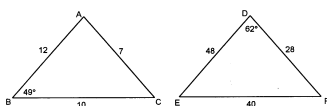

Figure 2.13

Activity 5

To apply similarity in problems

[LO 4.4, 1.4, 3.5]

- In the following problems, you must draw sketches of the given triangles, but you must NOT make accurate drawings.
1. Are the following triangles similar?
 - 1.1 $\triangle BAG$ with $\angle B = 90^\circ$, $AG = 15\text{cm}$ and $AB = 9\text{cm}$ and $\triangle POT$ with $\angle P = 90^\circ$, $OT = 5\text{cm}$ and $PO = 4\text{cm}$.
 - 1.2 $\triangle REM$ with $\angle R = 60^\circ$ and $\angle M = 50^\circ$ and $\triangle SUP$ with $\angle U = 70^\circ$ and $\angle S = 50^\circ$.
 - 1.3 $\triangle LOP$ with $\angle P = 90^\circ$, $LO = 13\text{cm}$ and $OP = 12\text{cm}$ and $\triangle CAT$ with $\angle C = 90^\circ$, $AC = 16\text{cm}$ and $CT = 12\text{cm}$
 2. Calculate the proportional constant in similar triangles $\triangle ABC$ and $\triangle DEF$ when $AB = 36\text{cm}$, $EF = 12\text{cm}$, $\angle C = 48^\circ$ and $\angle D = 48^\circ$.
 3. Two flagpoles (one longer than the other) throw shadows on the ground. The shadow of the longer pole (which is 8 m tall) is 3 m and the shorter flagpole has a 2,5 m shadow. Calculate how tall the short flagpole is.
 4. Gloria is designing a logo for her school's computer club. The design shows a computer next to a pile of books which is 50 % higher than the computer. She is photocopying the design to make it smaller. On the photocopy the computer is 18 cm high and on the original the pile of books is 54 cm high. By what factor is she making the design smaller?

2.2.6 Assessment

Learning outcomes(LOs)
<i>continued on next page</i>

LO 1
Numbers, Operations and RelationshipsThe learner will be able to recognise, describe and represent numbers and their relationships, and to count, estimate, calculate and check with competence and confidence in solving problems.
Assessment standards(ASs)
<i>We know this when the learner :</i>
1.1 describes and illustrates the historical development of number systems in a variety of historical and cultural contexts (including local);
1.2 recognises, uses and represent rational numbers (including very small numbers written in scientific notation), moving flexibly between equivalent forms in appropriate contexts;
1.3 solves problems in context, including contexts that may be used to build awareness of other Learning Areas, as well as human rights, social, economic and environmental issues such as:
1.3.1 financial (including profit and loss, budgets, accounts, loans, simple and compound interest, hire purchase, exchange rates, commission, rentals and banking);
1.3.2 measurements in Natural Sciences and Technology contexts;
1.4 solves problems that involve ratio, rate and proportion (direct and indirect);
LO 3
Space and Shape (Geometry)The learner will be able to describe and represent characteristics and relationships between two-dimensional shapes and three-dimensional objects in a variety of orientations and positions.
<i>We know this when the learner :</i>
3.1 recognises, visualises and names geometric figures and solids in natural and cultural forms and geometric settings, including;3.1.1 regular and irregular polygons and polyhedra;3.1.2 spheres;3.1.3 cylinders;3.2 in contexts that include those that may be used to build awareness of social, cultural and environmental issues, describes the interrelationships of the properties of geometric figures and solids with justification, including;3.2.1 congruence and straight line geometry;3.3 uses geometry of straight lines and triangles to solve problems and to justify relationships in geometric figures;3.4 draws and/or constructs geometric figures and makes models of solids in order to investigate and compare their properties and model situations in the environment;
<i>continued on next page</i>

3.5 uses transformations, congruence and similarity to investigate, describe and justify (alone and/or as a member of a group or team) properties of geometric figures and solids, including tests for similarity and congruence of triangles.
LO 4
MeasurementThe learner will be able to use appropriate measuring units, instruments and formulae in a variety of contexts.
<i>We know this when the learner :</i>
4.1 solves ratio and rate problems involving time, distance and speed;
4.2 solves problems (including problems in contexts that may be used to develop awareness of human rights, social, economic, cultural and environmental issues) involving known geometric figures and solids in a range of measurement contexts by:
4.2.1 measuring precisely and selecting measuring instruments appropriate to the problem;
4.2.2 estimating and calculating with precision;
4.2.3 selecting and using appropriate formulae and measurements;
4.3 describes and illustrates the development of measuring instruments and conventions in different cultures throughout history;
4.4 uses the Theorem of Pythagoras to solve problems involving missing lengths in known geometric figures and solids.

Table 2.8

2.2.7

2.2.8 Memorandum

Discussion

Point out to learners the relationships between angle sizes and lengths of opposite sides, i.e. that the largest angle lies opposite the longest side, etc. In this regard the following theorems are interesting:

In $\triangle ABC$:

As $b^2 = a^2 + c^2$, then $\overset{\ominus}{B} = 90^\circ$

As $b^2 > a^2 + c^2$, then $\overset{\ominus}{B} > 90^\circ$

As $b^2 < a^2 + c^2$, then $\overset{\ominus}{B} < 90^\circ$

- These relationships are easily confirmed by construction. If time allows, this could be a good basic familiarisation exercise.
- Many learners enter grade 9 without knowing that the relationship between the height and the base of a triangle is crucial in the formula for the area of a triangle. This is a good point to emphasize that the height is measured from the vertex opposite the base, perpendicular to the base. When they construct scalene triangles with three heights and then use these heights and the corresponding three bases to work out the area three times, this usually makes the point very clear.

Congruence

In the first exercise in activity 3.2 the learners should not work in very large groups – pairs would be best. The aim is to obtain as many versions of the triangles as possible, so as to confirm when they are congruent and when not. It would be best to give this exercise as a homework assignment if, in the teacher's judgement, the learners can do it without help.

When discussing the four cases of congruence, point out that two right-angled triangles are congruent if the two non-hypotenuse sides are respectively equal, not by the *RHS*-rule, but by the *SAS*-rule.

Learners have to become comfortable with the idea that figures need not be drawn to scale – and that the information given on the figure must be used. They must not measure attributes unless specifically asked to do so.

Answers to matching exercise:

A [U+FOBA] *O* (*SSS* or *RHS* from calculated hypotenuse, Pythagoras)

B [U+FOBA] *G* (*SAS*) They are not congruent to *I*, as the given angle is not included

C [U+FOBA] *F* [U+FOBA] *N* (*SSS* or *RHS* from calculated hypotenuse)

D, *L* and *K* are not congruent as only angles are given

E [U+FOBA] *H* (*AAS*) They are not congruent to *M*, as the given side is not in a corresponding position

- In doing proofs, rigour is not required from grade 9 learners. On the other hand, one of the strengths of learning geometry is that it teaches the learners to work in a logical and rigorous order. Make a point of encouraging this style from the type of learner who might benefit from it, particularly in further mathematics.

Congruency proofs:

$$1. [U+FOD0] C = 180^\circ - 88^\circ - 43^\circ = 49^\circ = [U+FOD0] F \text{ (angles of } \Delta \text{ sum to } 180^\circ)$$

$$[U+FOD0] B = 43^\circ = [U+FOD0] E \text{ (given)}$$

$$AB = 15 = DE \text{ opposite } 49^\circ\text{-angles (given)}$$

$$\Delta ABC [U+FOBA] \Delta DEF \text{ ([U+FOD0]S)}$$

$$2. BC = 12 = FE \text{ (Pythagoras)}$$

$$AC = 15 = DE \text{ (given)}$$

Right-angled triangles

$$\Delta ABC [U+FOBA] \Delta DFE \text{ (RHS)}$$

$$3. BC = BC \text{ (common or shared side)}$$

$$[U+FOD0] B = 55^\circ = [U+FOD0] C \text{ (given)}$$

$$[U+FOD0] A = [U+FOD0] D \text{ (given; shown by little arc)}$$

$$\Delta ABC [U+FOBA] \Delta DCB \text{ (RHS)}$$

Similarity

If a photocopier is available, teachers can design more exercises that will illustrate the principles of similarity by direct measurement.

Exercise:

$$[U+FOD0] Q = 55^\circ \text{ en } [U+FOD0] Z = 65^\circ$$

$$\Delta PQR [U+FOE7] [U+FOE7] [U+FOE7] \Delta XYZ \text{ (equiangular)}$$

$$213 = 3(71)$$

$$PR = 201 [U+FOB8] 3 = 67 \text{ en } XY = 74 \times 3 = 222$$

$$DE = AB \times 4, DF = AC \times 4 \text{ and } EF = BC \times 4$$

$$\Delta ABC [U+FOE7] [U+FOE7] [U+FOE7] \Delta DEF \text{ (sides are in proportion)}$$

Corresponding angles must be equal

$$[U+FOD0] A = [U+FOD0] D = 62^\circ; [U+FOD0] E = [U+FOD0] B = 49^\circ \text{ en } [U+FOD0] C = [U+FOD0] F = 69^\circ$$

(angles of Δ sum to 180°)

Exercise from activity 3.5:

$$1.1 \text{ Yes, Pythagoras gives } BG = 12 \text{ cm and } PT = 3 \text{ cm; sides in proportion}$$

1.2 Yes, $[U+FOD0] E = 70^\circ = [U+FOD0] U$ and $[U+FOD0] P = 60^\circ = [U+FOD0] R$ (angles of triangle); equiangular

$$1.3 \text{ No, } LP = 5 \text{ cm and } AT = 20 \text{ cm (Pythagoras); but sides are not in proportion}$$

$$2. \text{ Proportional constant} = 36 [U+FOB8] 12 = 3$$

$$3. \text{ Short flagpole is } 6,67 \text{ m tall}$$

$$4. \text{ Pile of books on photocopy is } 18 [U+FOB8] 2 \times 3 = 27 \text{ cm high}$$

$$54 [U+FOB8] 27 = 2 \text{ is the factor by which the design is made smaller.}$$

2.3 Space and shape³

2.3.1 MATHEMATICS

2.3.2 Grade 9

2.3.3 ALGEBRA AND GEOMETRY

2.3.4 Module 7

2.3.5 SPACE AND SHAPE

Activity 1:

To understand the structure of some regular right prisms

[LO 3.3, 3.4]

A. Building containers

You will be given a sheet of shapes. You will need a ruler that you can measure with, a pair of scissors and glue or sticky tape. Colouring pens will also be helpful. Do the following with these shapes:

1. Carefully measure all the lines and write down your measurements (you should be able to measure to the nearest half–millimetre). You must also do your best to measure the radius (or diameter) of the circle. If you have a protractor available, find out where the 90° –angles are.
2. Using these measurements, calculate the areas of the different shapes, and add the parts together to find out the total area of each of the four shapes. Set your work out very clearly so that anybody can understand what you have done. Use the proper names for the shapes you describe.

For example, for the last figure you could say:

Total area = small rectangle + small rectangle + large rectangle

= $(l \times b) + (l \times b) + (l \times b)$

and so on . . . (Remember to use appropriate units.)

1. Very carefully cut out the given shapes. You can colour these shapes to make it easier to see which the top and base are, and which the sides (the sides are striped). Now fold them and use tape, or glue and paper strips, to make four boxes. Keep the sides with the dotted lines on the outside.
2. Write down what the Total Surface Area (TSA) of each shape is. (You have already calculated the answer!)
3. Work in groups of two or three to try to find out how many $1\text{cm} \times 1\text{cm}$ blocks will fit into each box. This is called the volume of the box. If you can find a method or a formula that will work with each of the four shapes, write that down carefully.
4. At the end of this exercise, you should have two formulas.

B. Right prisms

- Each of the four boxes is a *right prism*. These are shapes with a top and base that are exactly the same size and shape, and sides that go up straight at right angles to the base. Look around to see whether you can discover shapes with these characteristics.
- We name right prisms according to the shape of the base, e.g. square prism, rectangular prism, triangular prism and circular prism (cylinder).
- Are these two shapes right prisms? Describe the shape of the base of each, and confirm whether the sides go straight up at right angles to the base.

³This content is available online at <<http://cnx.org/content/m31220/1.1/>>.



Figure 2.14

-
- What kind of work did you do in this section? Score yourself in this table.

Did i work	Excellent	Adequately	Not well enough
well with my team?			
according to instructions?			
carefully?			
accurately?			
neatly?			

Table 2.9

C. Formulas

- To calculate the total surface area (TSA) and volume (V) of any right prism we use the following general formulas: (Please note that H refers to the prism height.)

$TSA = 2 \times \text{base area} + \text{sides area}$ and $V = \text{base area} \times \text{prism height}$

Here are some important examples. These are the cut-out prisms you made into boxes. Please note how each part of the calculation is done separately and then put into the formula at the end.

1. Square prism:

$$TSA = 2 \text{ base area} + \text{sides area} = (2 \times s^2) + (H \times \text{base perimeter})$$



Figure 2.15

$$s = 28\text{mm}$$

Step 1: Determine what the base is and sketch it with its dimensions.
 Step 2: Calculate the base area.
 $\text{Base area} = s^2 = 28^2 = 784 \text{ mm}^2$
 Step 3: Calculate the base perimeter.
 $\text{Base perimeter} = 4 \times s = 112\text{mm}$
 Step 4: Write down the height of the prism.
 $H = 52\text{mm}$
 Step 5: Calculate the TSA and V.
 $V = 784 \times 52 = 40\,768 \text{ mm}^3 \approx 40,7 \text{ cm}^3$
 $\text{TSA} = (2 \times 784) + (52 \times 112) = 7\,392 \text{ mm}^2 \approx 73,9 \text{ cm}^2$

1. Rectangular prism:

$$\text{TSA} = 2 \text{ base area} + \text{sides area} = 2 (l \times b) + (H \times \text{base perimeter})$$



Figure 2.16

$l = 41\text{mm}; b = 14\text{mm}$
 Step 1: Determine what the base is and sketch it with its dimensions.
 Step 2: Calculate the base area.
 $\text{Base area} = l \times b = 41 \times 14 = 574 \text{ mm}^2$
 Step 3: Calculate the base perimeter.
 $\text{Base perimeter} = 2 (14 + 41) = 110\text{mm}$
 Step 4: Write down the height of the prism.
 $H = 54\text{mm}$
 Step 5: Calculate the TSA and V.
 $V = 574 \times 54 = 30\,996 \text{ mm}^3 \approx 31 \text{ cm}^3$
 $\text{TSA} = (2 \times 574) + (54 \times 110) = 7\,088 \text{ mm}^2 \approx 70,1 \text{ cm}^2$

1. Cylinder:



Figure 2.17

$$\text{TSA} = 2 \text{ base area} + \text{sides area} = 2 (\pi r^2) + (H \times \text{base perimeter})$$

$$r = 17,5\text{mm}$$

Step 1: Determine what the base is and sketch it with its dimensions.

Step 2: Calculate the base area.

$$\text{Base area} = \pi r^2 = 3,14159 \times (17,5)^2 \approx 962,1\text{mm}^2$$

Step 3: Calculate the base perimeter.

$$\text{Base perimeter} = 2 \pi r = 109,956\text{mm}$$

Step 4: Write down the height of the prism.

$$H = 60,5\text{mm}$$

Step 5: Calculate the TSA and V.

$$V = 962,1 \times 60,5 \approx 58\,207,8 \text{ mm}^3 \approx 58 \text{ cm}^3$$

$$\text{TSA} = (2 \times 962,1) + (60,5 \times 109,956) \approx 8\,576,55 \text{ mm}^2 \approx 85,8 \text{ cm}^2$$

1. Triangular prism:

$$\text{TSA} = 2 \text{ base area} + \text{sides area} = 2 \left(\frac{1}{2} \times b \times h \right) + (H \times \text{base perimeter})$$



Figure 2.18

$$b = 43,5\text{mm}; h = 31,5\text{mm}$$

$$\text{hypotenuse} = 53,7\text{mm (Pyth.)}$$

Step 1: Determine what the base is and sketch it with its dimensions.

Step 2: Calculate the base area.

$$\text{Base area} = \frac{1}{2} b \times h = 685,125 \approx 685,1\text{mm}^2$$

Step 3: Calculate the base perimeter.

$$\text{Base perimeter} = b + h + \text{hypotenuse} \approx 128,7\text{mm}$$

Step 4: Write down the height of the prism.

$$H = 60,5\text{mm}$$

Step 5: Calculate the TSA and V.

$$V = 685,1 \times 60,5 \approx 41\,450,1 \text{ mm}^3 \approx 41 \text{ cm}^3$$

$$\text{TSA} = (2 \times 685,1) + (60,5 \times 128,7) \approx 9\,157,06 \text{ mm}^2 \approx 91,6 \text{ cm}^2$$

Exercise:

Calculate the total surface area and the volume of each of the following three prisms.

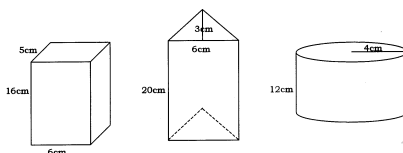

Figure 2.19

Assignment to be done in pairs:

- Help Granny solve her problem. She has cooked a pot of peach jam. The jam is 2 cm from the top rim of her cooking pot which has a diameter of 24 cm and is 21 cm high.
- She has some pretty jam jars which she wants to fill to about $\frac{1}{2}$ cm from the top.

- She has two types of jam jar. The brown kind has a square base ($8\text{ cm} \times 8\text{ cm}$) and is 12 cm high, and the yellow kind has a base of $6,5\text{ cm} \times 11,5\text{ cm}$ and is 11 cm high. There are eleven of each kind.
- Her problem is that she wants to use only one type of jar for the peach jam. This means that she does not want to start filling one kind of jar and then find that she has jam left over when she has used up all eleven jars.
- Your job is to find out for her whether she has enough jars of one type to fit her jam into, and to tell her which kind to use.

Activity 2

To become acquired with various two- and three-dimensional figures

[LO 3.1, 3.5]

A. Two-dimensional figures

These are figures that can be drawn on flat paper. Therefore they are called *plane* figures. Of course there are limitlessly many such figures.

Polygons are *closed* figures with three or more straight sides. If all the sides are the same length, and all the internal angles are equal, we call them *regular* polygons. Triangles are three-sided polygons, and an *equilateral* triangle is a *regular* three-sided polygon. A square is a regular four-sided polygon. *Pentagons* have five sides, hexagons have six sides and heptagons have seven. Make a list of as many of these special names as you can find.

Here are several closed plane figures. Decorate them and write the name of each polygon on the shape.

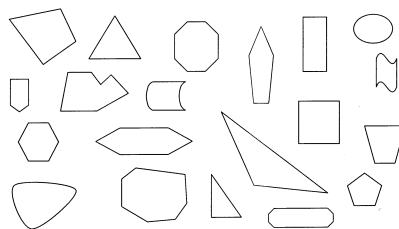

Figure 2.20

B. Investigation

Choose four polygons from the group above, all regular, but with four different numbers of sides. Now measure the sizes of the internal angles of each. Try to find out whether it is possible to make a formula to tell you how large the angles are, and what they add up to.

The following table will be helpful. As you can see, there are infinitely many polygons.

No. of sides	$a = \text{internal angle size}$	$b = 360 - a$	$c = b - 180$	Total of a	Total of c
Three				$3 \times a =$	$3 \times c =$
Four				$4 \times a =$	$4 \times c =$
Five				$5 \times a =$	$5 \times c =$
Six				$6 \times a =$	$6 \times c =$
Seven				$7 \times a =$	$7 \times c =$
Twelve				$12 \times a =$	$12 \times c =$

Table 2.10

- The characteristics in the table above are needed when you have to decide how to tile a floor (say) with regular polygons so that they don't overlap and don't leave gaps. Some of these polygons will work alone, and some can or must be combined.
- Design and draw a repeating tiling pattern of your own, using only regular polygons and colour it so that the pattern shows clearly.

C. Three-dimensional closed figures

- If these shapes have sides made up of polygons, then we call them *polyhedra*. A *regular* polyhedron has faces that are congruent regular polygons, with internal angles the same shape and size.
- In contrast to the polygons, there are only five regular polyhedra. They have been known since the time of Plato and the Greek mathematicians; this is why they are known as the five Platonic Solids.

D. Project

Research the five Platonic Solids, finding their names and properties, and other interesting deductions and facts about them. Make an attractive poster or models of these solids showing the facts associated with each. Below are pictures of the five solids.

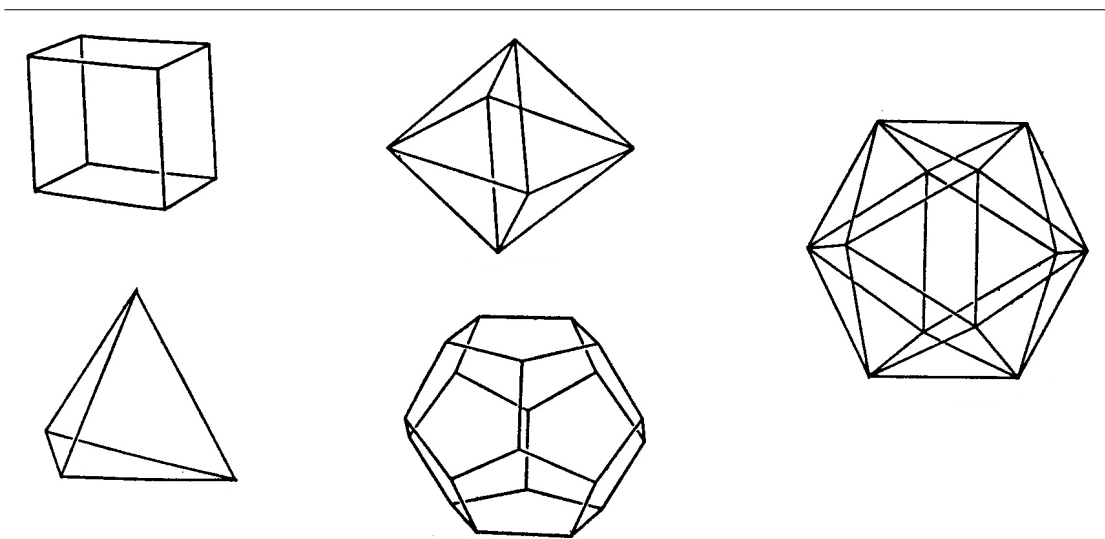

Figure 2.21

2.3.6 Assessment

LO 3
<i>continued on next page</i>

Space and Shape (Geometry)The learner will be able to describe and represent characteristics and relationships between two-dimensional shapes and three-dimensional objects in a variety of orientations and positions.
<i>We know this when the learner :</i>
3.1 recognises, visualises and names geometric figures and solids in natural and cultural forms and geometric settings, including:3.1.1 regular and irregular polygons and polyhedra;3.1.2 spheres;3.1.3 cylinders;3.2 in contexts that include those that may be used to build awareness of social, cultural and environmental issues, describes the interrelationships of the properties of geometric figures and solids with justification, including:3.2.1 congruence and straight line geometry;3.3 uses geometry of straight lines and triangles to solve problems and to justify relationships in geometric figures;3.4 draws and/or constructs geometric figures and makes models of solids in order to investigate and compare their properties and model situations in the environment;
3.5 uses transformations, congruence and similarity to investigate, describe and justify (alone and/or as a member of a group or team) properties of geometric figures and solids, including tests for similarity and congruence of triangles.

Table 2.11

2.3.7 Memorandum

Discussion

- This guide includes two pages of figures for constructing simple right prisms. Photocopy enough for the learners to make at least two of the figures. It would be best if the copies could be made on very light card (or heavy paper). If they are asked to colour some of the parts (e.g. the base and top) it might make it easier to explain some of the more difficult formulae.
- The two formulae for right prisms are, in general:
- Total Surface Area = double the base area + height of prism \times perimeter of base
- Volume = base area \times height of prism
- Ensure that learners are clear on the units (squared or cubed) appropriate to each formula.
- Another difficulty that learners might encounter is that the word *height* is used in calculating the area of triangles as well as being one of the dimensions of right prisms. A useful trick is to use **h** for the triangle case and **H** for the prism case.
- Breaking down the steps required for the calculations is a useful method for learners who get confused by the components in the formula. Of course, very competent learners will substitute values straight into the formula. This is an effective system, and should be encouraged where appropriate.

Solutions – exercise:

Rectangular prism: $TBO = 412 \text{ cm}^2$ Vol = 480 cm^3

Triangular prism: $TBO = 307,71 \text{ cm}^2$ Vol = 360 cm^3

Cylinder: $TBO = 402,12 \text{ cm}^2$ Vol = $603,19 \text{ cm}^3$

Granny's Jam Pot: Vol = $8\,595,40 \text{ cm}^2$

11 Square-based jars: Vol = $8\,096 \text{ cm}^2$

11 Rectangle-based jars: Vol = $8\,633,63 \text{ cm}^2$

So, granny must use the rectangular-based jars if she wants to fit all the jam in!

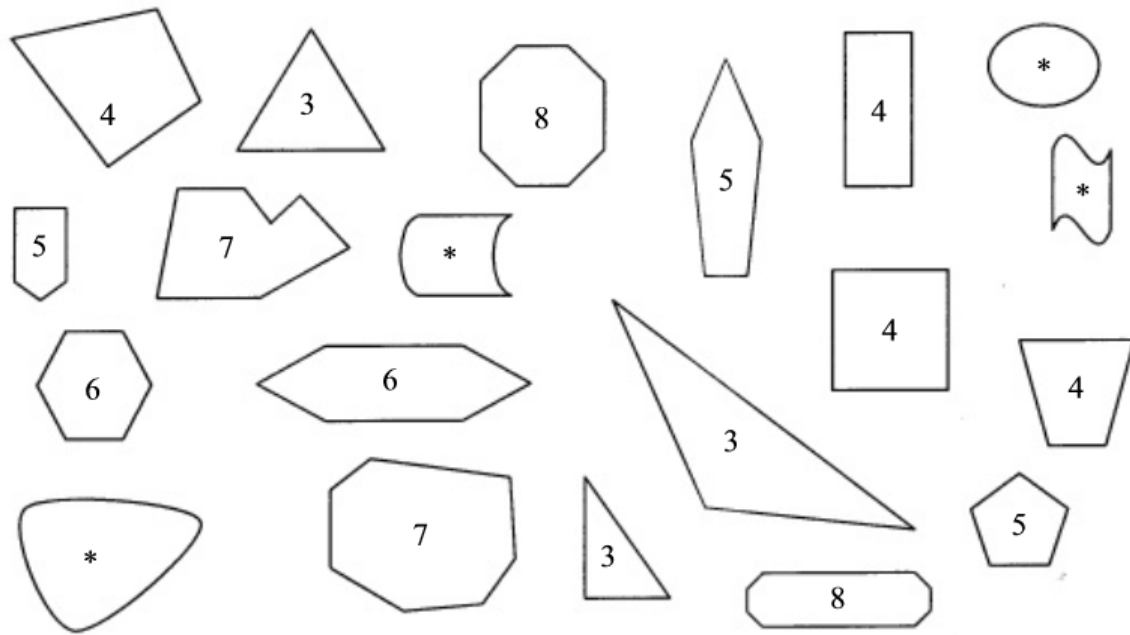

Figure 2.22

3 = triangle; 4 = tetragon; 5 = pentagon; 6 = hexagon; 7 = heptagon; 8 = octagon; * = not polygon

No of sides	$a = \text{internal angle size}$	$b = 360^\circ - a$	$c = b - 180^\circ$	Total of a	Total of c
Three	60°	300°	120°	$3 \times a = 180^\circ$	$3 \times c = 360^\circ$
Four	90°	270°	90°	$4 \times a = 360^\circ$	$4 \times c = 360^\circ$
Five	108°	252°	72°	$5 \times a = 540^\circ$	$5 \times c = 360^\circ$
Six	120°	240°	60°	$6 \times a = 720^\circ$	$6 \times c = 360^\circ$
Seven	$308,57^\circ$	$51,43^\circ$	$-128,57^\circ$	$7 \times a = 2160^\circ$	$7 \times c = -360^\circ$
Twelve	330°	30°	-150°	$12 \times a = 3960^\circ$	$12 \times c = -360^\circ$

Table 2.12

TEST 1

1. Explain how you would recognise a right prism.
2. Explain how you could find the base of a right prism.
3. Calculate the total surface area and the volume of each of the following three prisms. Give your answers accurate to two decimal places.

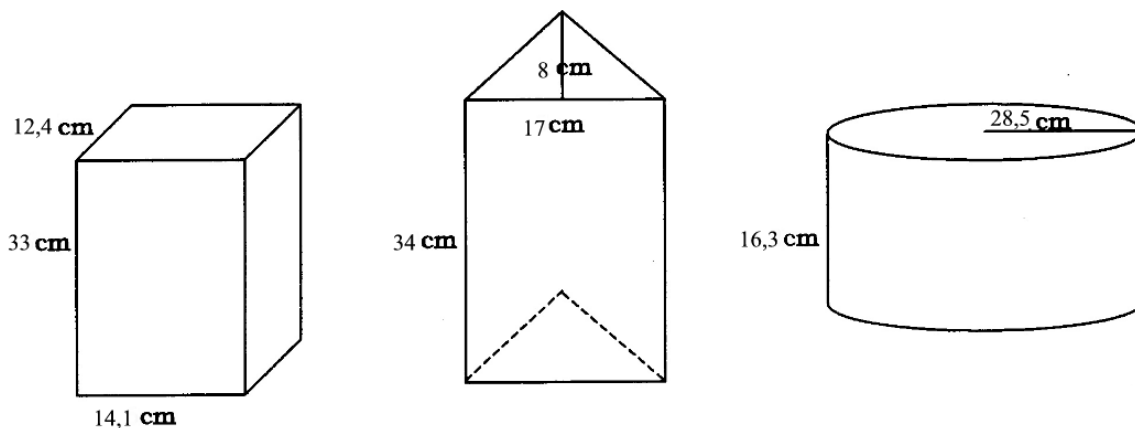

Figure 2.23

TEST 1 – Memorandum

- Essential points in the explanation: three-dimensional; top and base congruent plane shapes; side(s) at right angles to base.
- Any reasonable explanation, e.g. if the chosen side is placed at the bottom, the description of a right prism fits what you see.
- Rectangular right prism: $TBO = 1\,939,68\text{ cm}^2$ Volume = $5\,769,72\text{ cm}^3$
 Triangular right prism: $TBO = 1\,507,74\text{ mm}^2$ Volume = $2\,312\text{ mm}^3$
 Cylinder: $TBO = 8\,022,37\text{ m}^2$ Volume = $41\,593,67\text{ m}^3$

2.4 Congruency⁴

2.4.1 MATHEMATICS

2.4.2 Grade 9

2.4.3 ALGEBRA AND GEOMETRY

2.4.4 Module 9

2.4.5 CONGRUENCY

- The term congruency means that two figures are identical in every way. It therefore means that all the sides of the one figure are equal to all the sides of the other figure and that all the angles of one figure are equal to all the angles of the other figure. If the figures are cut out, they will fit precisely on one another.

ACTIVITY 1

To understand what the term congruency in general means
 [LO 3.2.1]

⁴This content is available online at <http://cnx.org/content/m31234/1.1/>.

Study the figures on the grid (A-1) and decide which of them are congruent. Then give each pair of congruent figures by writing them down with the letters in order of the sides and angles which are equal. The symbol for congruency is [U+FOBA].

For example:

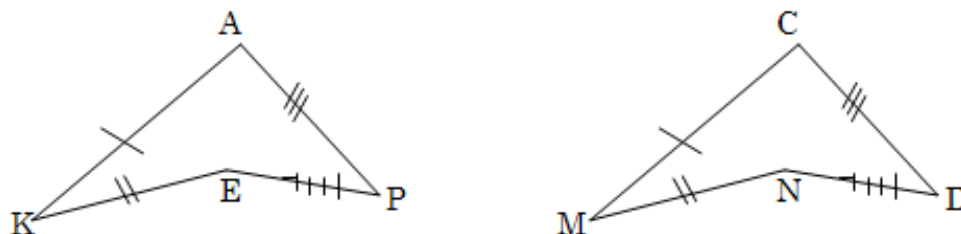

Figure 2.24

Quadrilateral APEK [U+FOBA] Quadrilateral CDN M

- A triangle has six elements; namely three angles and three sides. Only three of these elements are needed to construct a triangle:
- Combinations of the three elements are:
 - 3 sides (sss)
 - 2 sides and the angle between them (s[U+FODO]s)
 - 2 angles and a side ([U+FODO] [U+FODO]s)
 - 2 sides and the angle not between them (ss[U+FODO])
 - 3 angles ([U+FODO] [U+FODO] [U+FODO])
 - A 90° - angle, a side and the hypotenuse (90° ss or rhs)

ACTIVITY 2

To practically determine what the conditions for congruent triangles are

- You are given four pages with accurately constructed triangles.

1.1 Study **page A-2** of the accurately constructed triangles. Study the triangles which were constructed by using three given sides and write down all the pairs of triangles which are congruent (**sss**). Remember that, as in activity 1, the triangles must be written down in order of the sides which are equal to each other.

1.2 Will two triangles of which the sides of the one triangle are equal to the sides of the other triangle **always** be congruent to each other?

1.3 If you only receive the information as in the sketches below, can you always with certainty say that the two triangles will be congruent? (Remember no real lengths are given).

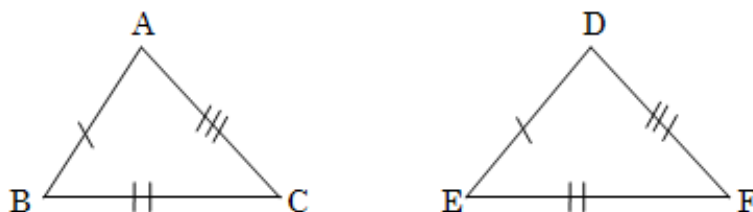

Figure 2.25

2.1 Again study **page A-2** of the accurately constructed triangles. Now look at the triangles constructed by using two sides and the angle between the two given sides, (s[U+FOD0]s), and write down all the pairs of triangles which are congruent. Again remember to write down the triangles in order of the side, angle, side which are equal.

2.2 Will two triangles of which two sides and the angle between them are equal, always be congruent?

2.3 If you only receive the information as in the sketches below, can you always with certainty, say that the two triangles will be congruent? (Remember no real lengths or magnitudes of angles are given).

3.1 **On page A-3** of the accurately constructed triangles two angles and a side ([U+FOD0][U+FOD0]s) are used to construct the triangles. Study these triangles and write down the pairs of triangles, which are congruent. Again remember to write down the triangles in order of the elements, which are equal.

3.2 In $\triangle DOM$ and $\triangle LOC$ $DM = OC$, $[U+FOD0]D = [U+FOD0]O$ en $[U+FOD0]M = [U+FOD0]L$, but these two triangles are not congruent. Why is that so? Give a general rule by completing the following sentence:

Two triangles are congruent if angle, angle, side of the one triangle are equal to angle, angle and theside of the other triangle.

3.3 If you only receive the information as in the sketches below, can you say with certainty that the two triangles are **always** congruent?

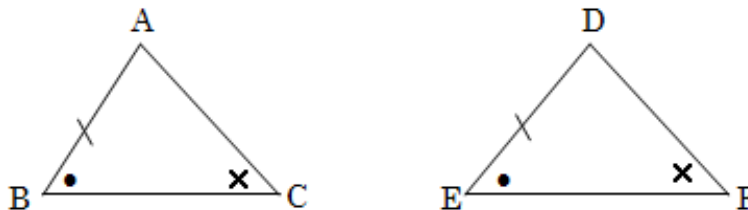

Figure 2.26

DEF ρ [U+F0B7]CBA[U+F0B7] ρ 3.4 Will the following two triangles be congruent? Why?

4.1 **Study page A-4** of the accurately constructed triangles. All the triangles on page A-4 were constructed by using two sides and the angle not between the two given sides, (ss[U+FOD0]) Study these triangles and write down the pairs of triangles which are congruent. Again remember to write down the triangles in order of the elements which are equal.

4.2 There are two triangles, which, although the two sides and the angle are equal, are not congruent. Name them.

4.3.1 Do you think that, if two sides and the angle not between the two sides, are used to construct triangles they would **always** be congruent?

4.3.2 What condition must the given sides satisfy for the triangles to be congruent?

4.4.4 If you only receive the information as in the sketches below, can you with certainty say that the two triangles are **always** congruent? (Remember you now do not know what the lengths of the two given sides).

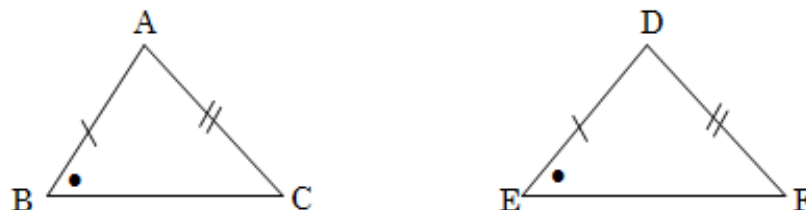

Figure 2.27

4.5.1 There are four triangles on **page A-4** where the given angle is 90° . If the angle not between the two given sides is equal to 90° , do you think that the two triangles will always be congruent? (**rhs**)

4.5.2 If you only receive the information like in the two sketches below, can you with certainty say that the two triangles are **always** be congruent?

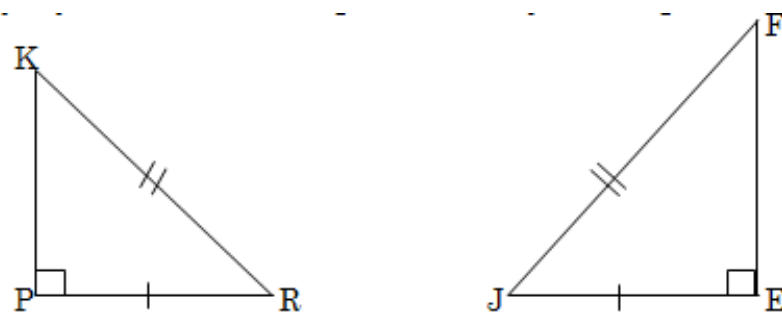

Figure 2.28

5. On **page A-5** there are triangles of which the three angles of the one triangle are equal to the three angles of the other triangle. ([U+FODO] [U+FODO] [U+FODO])

5.1 Are the triangles constructed like this **always necessarily** congruent?

5.2 If you only receive the information like in the two sketches below, can you with certainty say that the two triangles are **always** be congruent?



Figure 2.29

6. Now give the combinations of sides and angles for triangles to be congruent. Illustrate each combination as in the example below:

1.

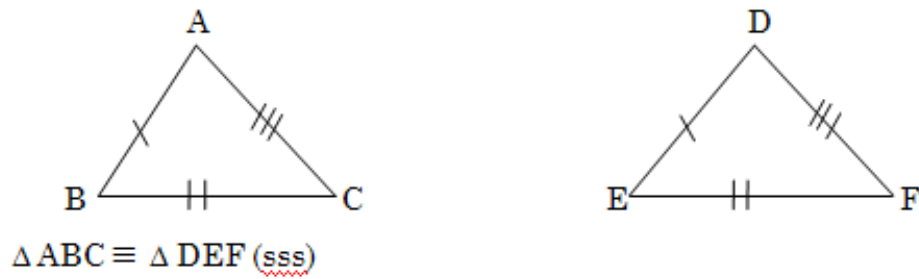

Figure 2.30

Homework assignment

1. State whether the following pairs of triangles are congruent or not. Do each number like the example below.

Example:

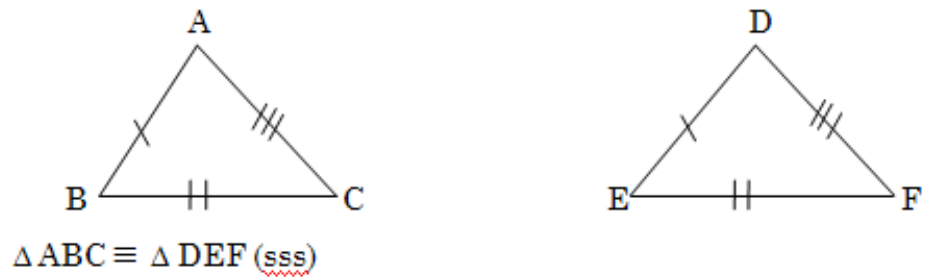

Figure 2.31

[U+F05C] [U+F0D0] A = [U+F0D0] D; [U+F0D0] B = [U+F0D0] E and [U+F0D0] C = [U+F0D0] F

N.B. If the triangles are not necessarily congruent, only write $\triangle ABC$ [U+F0BA] $\triangle DEF$ and then write down why you say so.

- The triangles are not drawn to scale. You must only use the given information in each of the figures.

1.1.

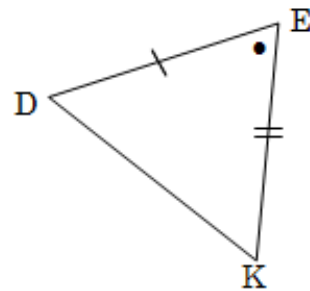
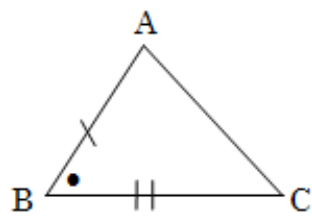

1.2.

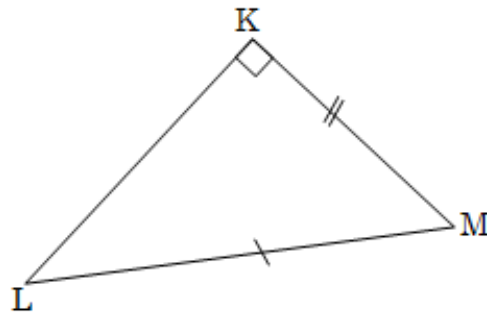
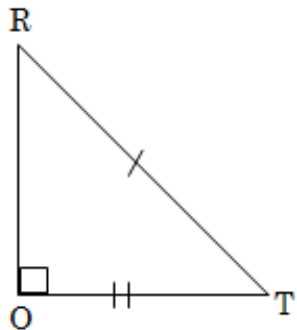

Figure 2.32

1.3.

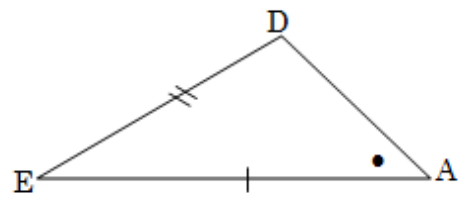
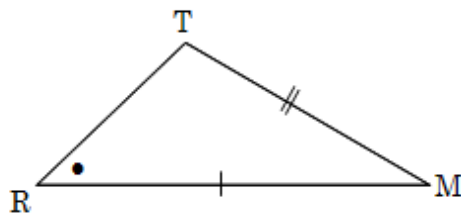
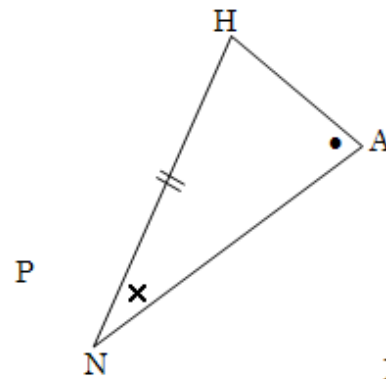
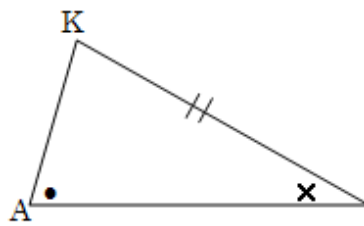

Figure 2.33

1.4.



1.5.

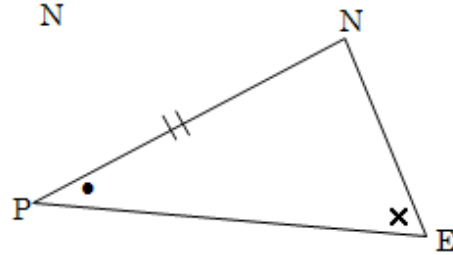
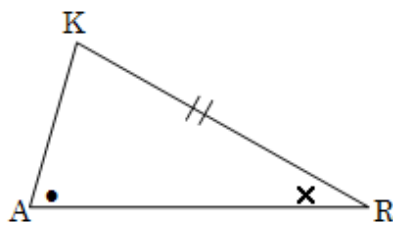

Figure 2.34

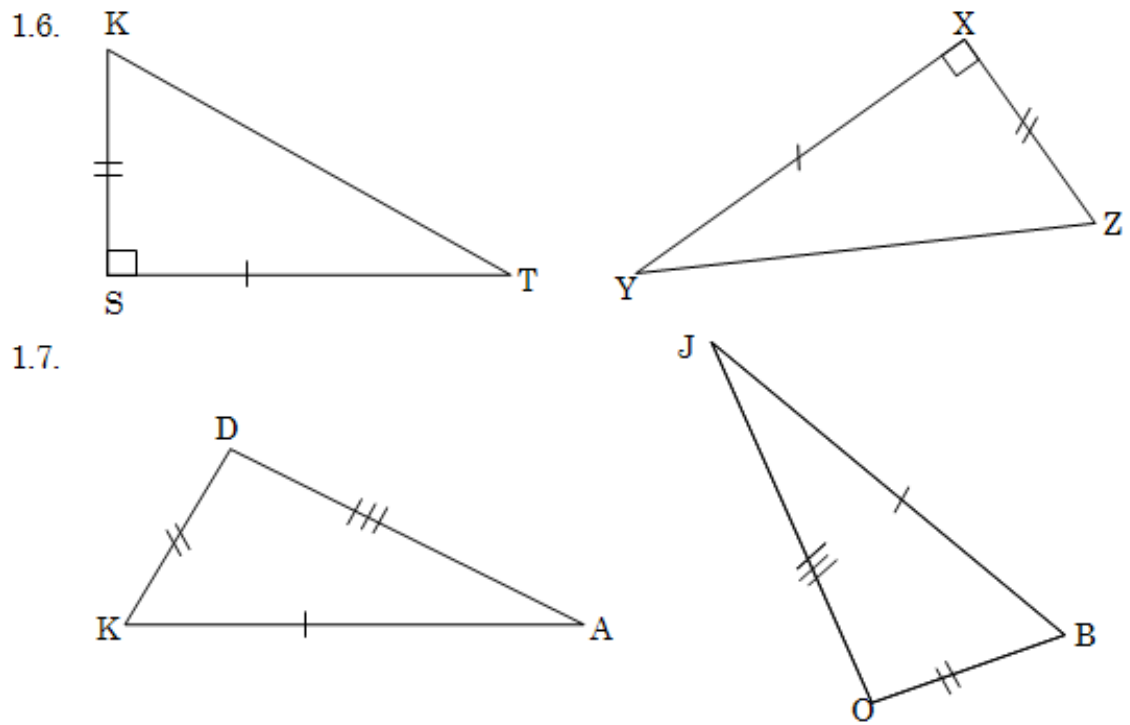

Figure 2.35

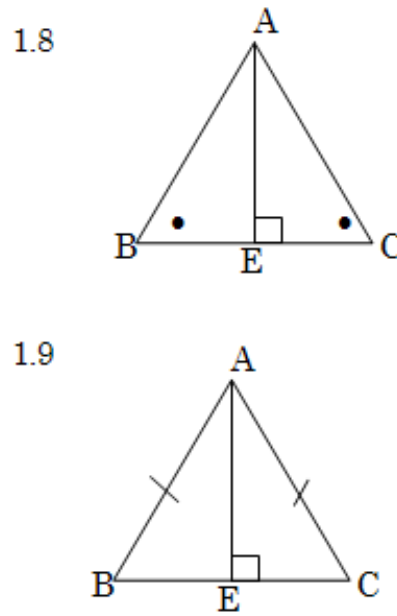

Figure 2.36

2. In each of the following pairs of triangles two pairs of equal elements are marked. In each case write down another pair of equal elements for the triangles to be congruent. Give the congruency test which you used and also give all the possibilities without repeating a congruency test.

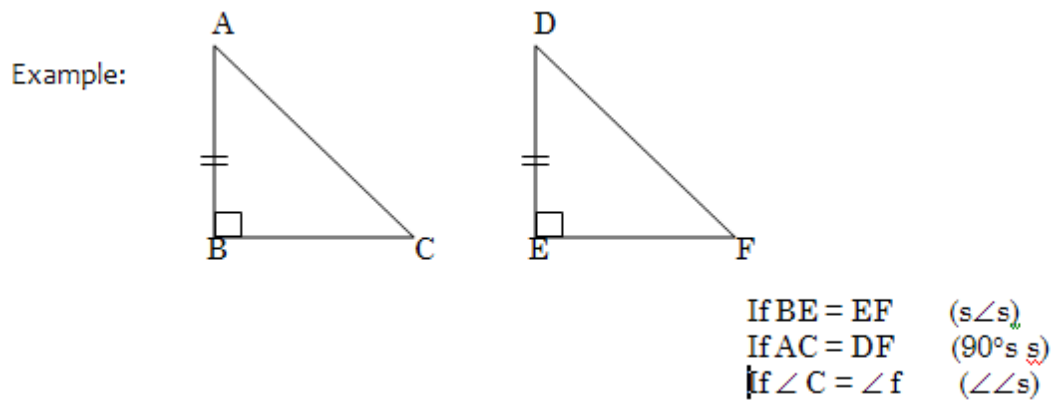
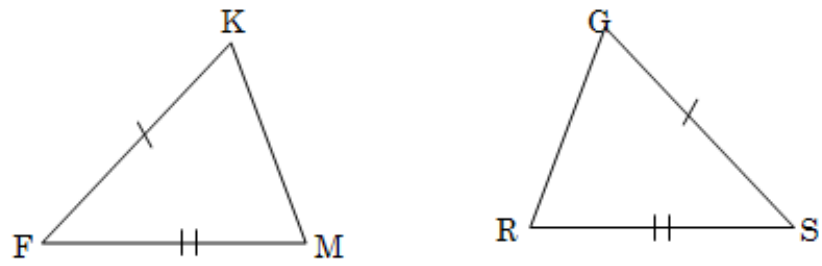

Figure 2.37

2.1



2.2

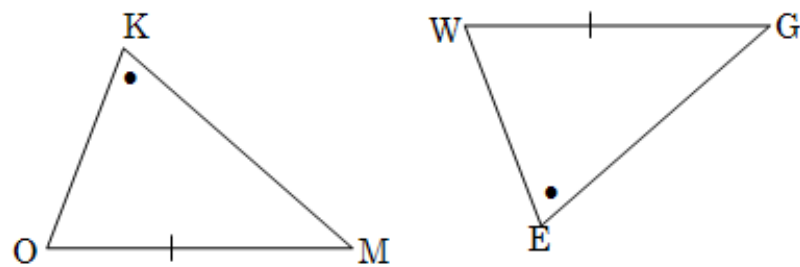
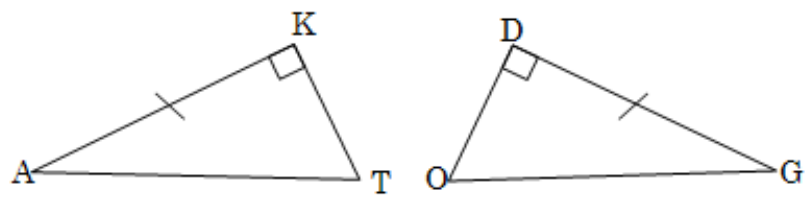

Figure 2.38

2.3



2.4

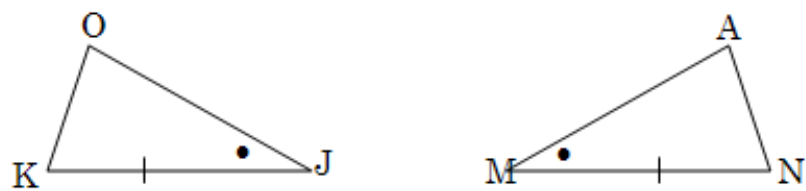

Figure 2.39

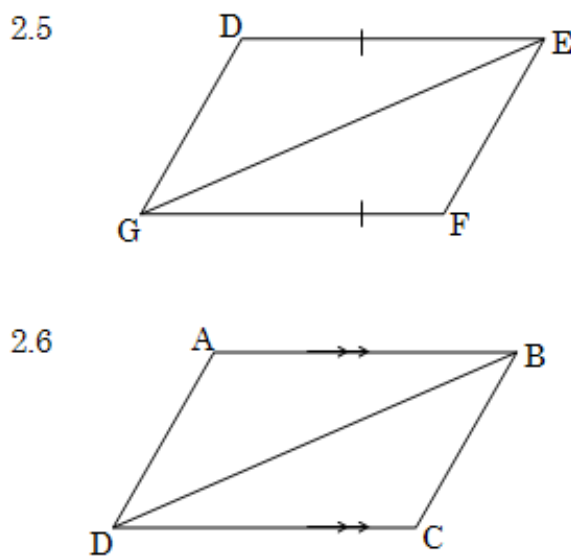

Figure 2.40

2.4.6 Assessment

LO 3
Space and Shape (Geometry)The learner will be able to describe and represent characteristics and relationships between two-dimensional shapes and three-dimensional objects in a variety of orientations and positions.
<i>We know this when the learner :</i>
3.1 recognises, visualises and names geometric figures and solids in natural and cultural forms and geometric settings, including:3.1.1 regular and irregular polygons and polyhedra;3.1.2 spheres;3.1.3 cylinders;3.2 in contexts that include those that may be used to build awareness of social, cultural and environmental issues, describes the interrelationships of the properties of geometric figures and solids with justification, including:3.2.1 congruence and straight line geometry;3.3 uses geometry of straight lines and triangles to solve problems and to justify relationships in geometric figures;3.4 draws and/or constructs geometric figures and makes models of solids in order to investigate and compare their properties and model situations in the environment;
<i>continued on next page</i>

3.5 uses transformations, congruence and similarity to investigate, describe and justify (alone and/or as a member of a group or team) properties of geometric figures and solids, including tests for similarity and congruence of triangles.

Table 2.13

2.5 Similarity⁵

2.5.1 MATHEMATICS

2.5.2 Grade 9

2.5.3 ALGEBRA AND GEOMETRY

2.5.4 Module 10

2.5.5 SIMILARITY

ACTIVITY 1:

To practically investigate the conditions for similarity

1. The pentagons ABDEF and LCMRK are given (A-6). LCMRK is an enlargement of ABDEF. What is the scale factor by which ABDEF were enlarged to give LCMRK?
2. Write down the ratios between the corresponding pairs of sides of ABDEF and LCMRK.
3. Write down the relationship between the corresponding pairs of angles of the two figures.
4. These two figures are not congruent. What do we call them?
5. Name as many as possible examples of this phenomenon in real life.

Similar figures:

- The pentagons in the activity above are similar. They have the same form, but do not have the same size.
- Their corresponding angles have the same magnitudes.
- Their corresponding sides are in the same ratio.

Therefore $\frac{LK}{AF} = \frac{KR}{FE} = \frac{MR}{DE} = \frac{CM}{BD} = \frac{CL}{BA} = \frac{3}{1}$ This constant ratio also is the scale factor of the enlargement.

- We say that ABDEF [U+FOEA] [U+FOEA] [U+FOEA] LCMRK. Note that the order of the letters is in the same order of the angles which are equal and the sides which are in proportion. (The symbol for similarity is [U+FOEA] [U+FOEA] [U+FOEA])

Homework assignment

1. Measure the lengths of the sides and the magnitudes of the angles in the following figures (A-7) and decide whether they are similar or not. If the two figures are not similar, give a reason why they are not similar.

2. If the corresponding **angles** of two quadrilaterals are **equal**, are they **necessarily** also **similar**?
3. If corresponding **sides** of two quadrilaterals are **proportional**, are they **necessarily** also **similar**?

- In the homework assignment above you saw that, for quadrilaterals to be similar, both conditions of similarity must be satisfied. In other words, the corresponding angles must be equal and the corresponding sides must be proportional. Do the same conditions also apply to triangles?

⁵This content is available online at <<http://cnx.org/content/m31235/1.1/>>.

ACTIVITY 2:

To practically investigate the conditions for similarity in triangles
[LO 3.5]

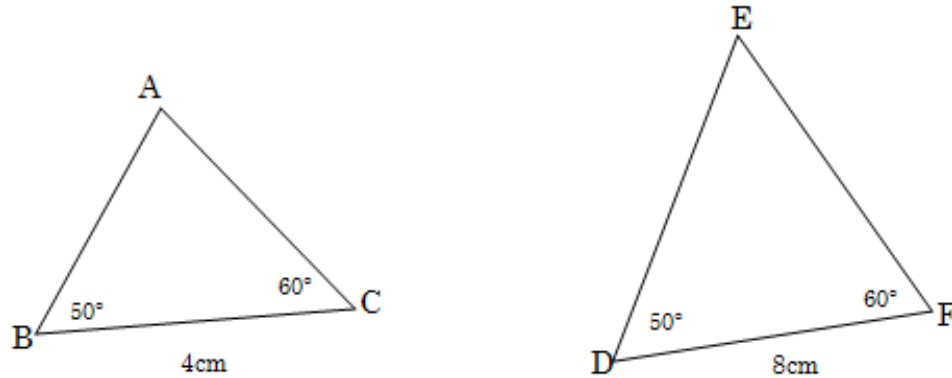

Figure 2.41

Construct $\triangle ABC$ and $\triangle DEF$. Calculate the magnitudes $\angle A$ and $\angle E$.

1.2 Are the corresponding angles of the two triangles equal?

1.3 Complete the following:

$$\frac{AB}{ED} = \dots\dots\dots$$

$$\frac{BC}{DF} = \dots\dots\dots$$

$$\frac{AC}{EF} = \dots\dots\dots$$

1.4 Are the corresponding sides of the two triangles proportional?

1.5 Are the two triangles similar?

1.6 Complete the following: If the corresponding angles of two triangles are equal, their corresponding sides are necessarily also always This means that, if the corresponding angles of triangles are equal the triangles are

2.1 Construct the following two triangles:

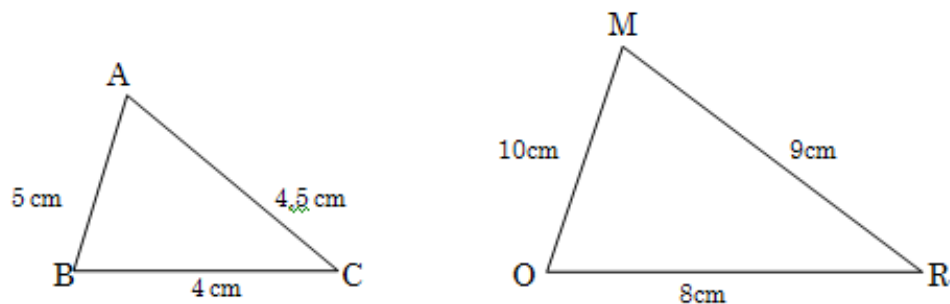

Figure 2.42

2.2 Are the sides of the two triangles proportional?

2.3 Measure all the angles of $\triangle ABC$ and $\triangle MOR$. What do you find?

2.4 Is $\triangle ABC \sim \triangle MOR$?

2.5 Complete the following: If the corresponding sides of two triangles are proportional then their corresponding are equal. That therefore means that, if the corresponding sides of two triangles are proportional, the triangles are.....

- We therefore see that with triangles only one of the conditions of similarity have to be present for triangles to be similar.
- That means that, if the **three angles** of **one triangle** are equal to the **three angles** of the **other triangle**, then the corresponding sides of the two triangles are proportional and the triangles are therefore also similar.
- It also means that, if the **corresponding sides** of the triangles are **proportional**, then the corresponding angles of the two triangles are equal and the triangles are therefore also similar.

Homework assignment

1. The following pairs of triangles are given. State whether they are similar or not and give reasons for you answer. If the two triangles are similar, calculate the lengths of the sides not given and also the magnitudes of the angles not given in the figure.

Example:

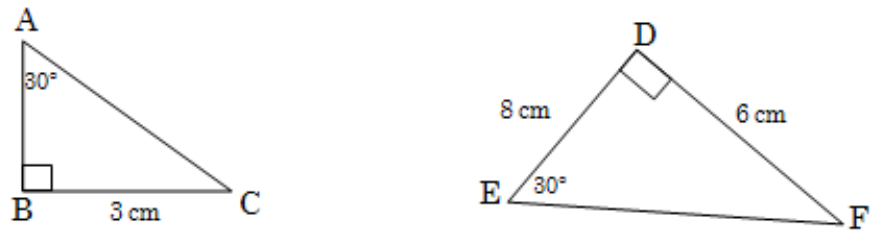

Figure 2.43

$\angle C = \angle F = 60^\circ$ $\triangle ABC \sim \triangle EDF$
 $(\angle C = \angle F)$
 $AB = 4 \text{ cm}$ $AC = 5 \text{ cm}$ (pyth) $EF = 10 \text{ cm}$
 1.1.

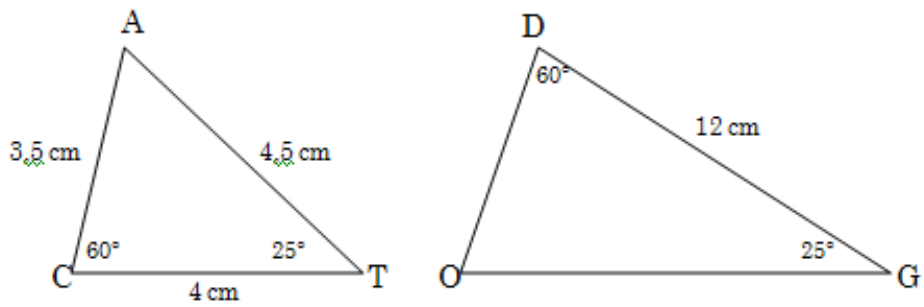

Figure 2.44

1.2

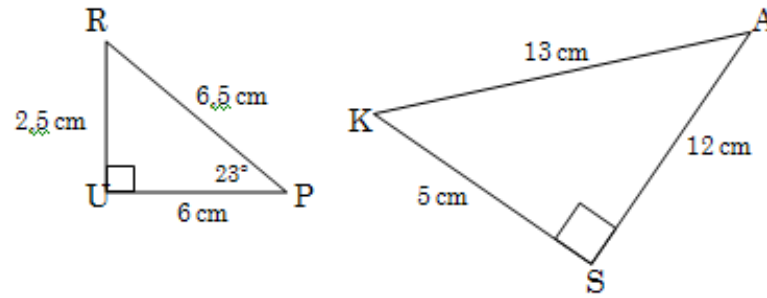

Figure 2.45

1.3.

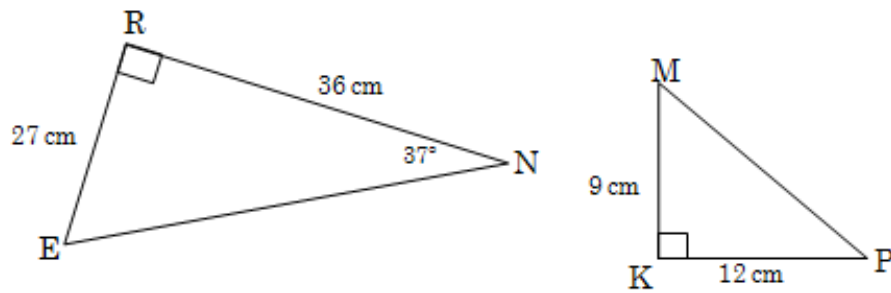

Figure 2.46

1.4

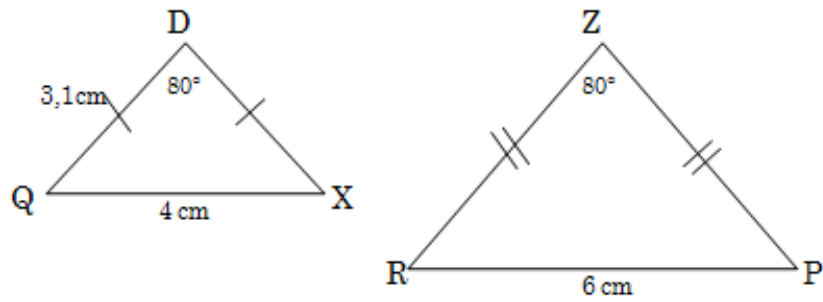

Figure 2.47

2.

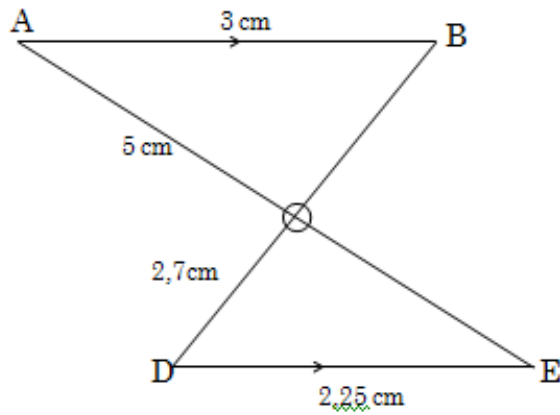

Figure 2.48

2.1 Complete the following:

In $\triangle AOB$ and $\triangle DOE$:

Reason

[U+FOD0]..... = [U+FOD0]..... (.....)

[U+FOD0]..... = [U+FOD0]..... (.....)

[U+F05C] \triangle [U+FOEA] [U+FOEA] [U+FOEA]..... ([U+FOD0] [U+FOD0] [U+FOD0])

2.2 Now calculate the lengths of the sides not given in the figure.

3.

In the figure $FH = 12$ cm.

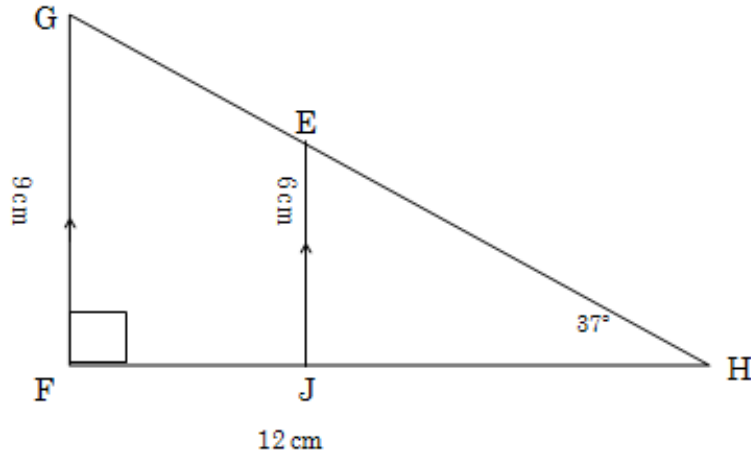

Figure 2.49

3.1 Complete the following:

In Δ and Δ

[U+FODO]..... = [U+FODO]..... (.....)

[U+FODO]..... = [U+FODO]..... (.....)

[U+F05C] Δ [U+FOEA] [U+FOEA] [U+FOEA]..... ([U+FODO] [U+FODO] [U+FODO])

3.2 Calculate the lengths of the following:

3.2.1 HE

3.2.2 EG

3.2.3 FJ

4. The height of a high vertical object can be determined by measuring the length of the shadow of a stick of known length and the shadow of the object. The following figures give the measurements which were made.

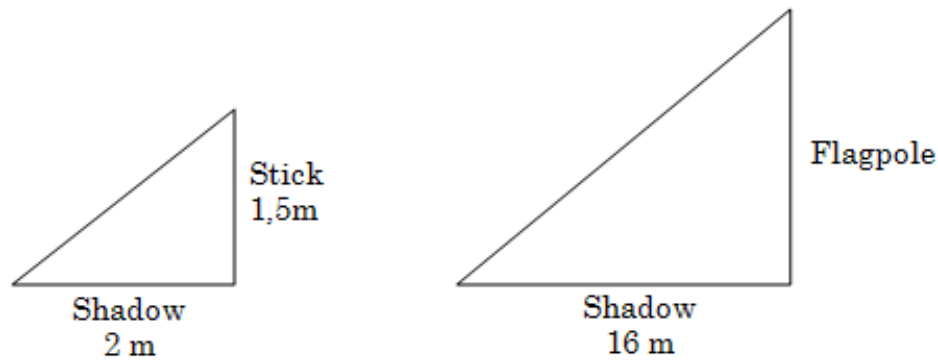

Figure 2.50

Determine the length of the flagpole.

ASSESSMENT TASK:

To use similarity to calculate the height of an object:

- Work together in pairs.
1. The following are needed:
 - A measuring tape of at least 5 m
 - A mirror
 - A ruler
 - A Koki pen
 2. You do the following:
 - Look for two high vertical objects on the school grounds; for example a netball pole, a lamp pole, rugby poles or a flagpole. Look for objects of which the heights are normally difficult to measure using normal methods.
 - Draw two thin lines on the mirror using the Koki pen so that the lines are perpendicular to each other.
 - Place the mirror a distance from the object on level ground.
 - One person should then step back and look in the mirror and change his / her position until the top of the object is precisely on the point of intersection of the two lines in the mirror.
 3. Measure the following:
 - the height of the eyes above the ground of the person who looked in the mirror;
 - the distance between the person who looked in the mirror and the point of intersection of the lines in the mirror'
 - the distance between the object and the point of intersection of the lines in the mirror.

Results:

1. Copy the table on folio paper and complete it:

The object of which the height is measured	The height of the eyes of the person above the ground.	Distance between the person and the point of intersection of the lines in the mirror	Distance between the point of intersection of the lines in the mirror and the object	Calculate the height of the object correct to the nearest cm

Table 2.14

2.

PKSLV

In the sketch PK is the height of the eyes of the person, S is the position of the mirror and VL is the height of the object, which is measured. Explain why $\triangle PKS$ [U+FOEA] [U+FOEA] $\triangle VLS$.

3. In this task the measurements can be inaccurate. Explain which mistakes could have been made, which could influence the accuracy of the height of the object measured.

2.5.6 Assessment

LO 3
Space and Shape (Geometry)The learner will be able to describe and represent characteristics and relationships between two-dimensional shapes and three-dimensional objects in a variety of orientations and positions.
<i>We know this when the learner :</i>
3.1 recognises, visualises and names geometric figures and solids in natural and cultural forms and geometric settings, including:3.1.1 regular and irregular polygons and polyhedra;3.1.2 spheres;3.1.3 cylinders;3.2 in contexts that include those that may be used to build awareness of social, cultural and environmental issues, describes the interrelationships of the properties of geometric figures and solids with justification, including:3.2.1 congruence and straight line geometry;3.3 uses geometry of straight lines and triangles to solve problems and to justify relationships in geometric figures;3.4 draws and/or constructs geometric figures and makes models of solids in order to investigate and compare their properties and model situations in the environment;
3.5 uses transformations, congruence and similarity to investigate, describe and justify (alone and/or as a member of a group or team) properties of geometric figures and solids, including tests for similarity and congruence of triangles.

Table 2.15

2.6 Worksheets⁶

2.6.1 MATHEMATICS

2.6.2 Grade 9

2.6.3 ALGEBRA AND GEOMETRY

2.6.4 Module 11

2.6.5 WORKSHEETS WITH MODULES 9 AND 10

2.6.6 A -1

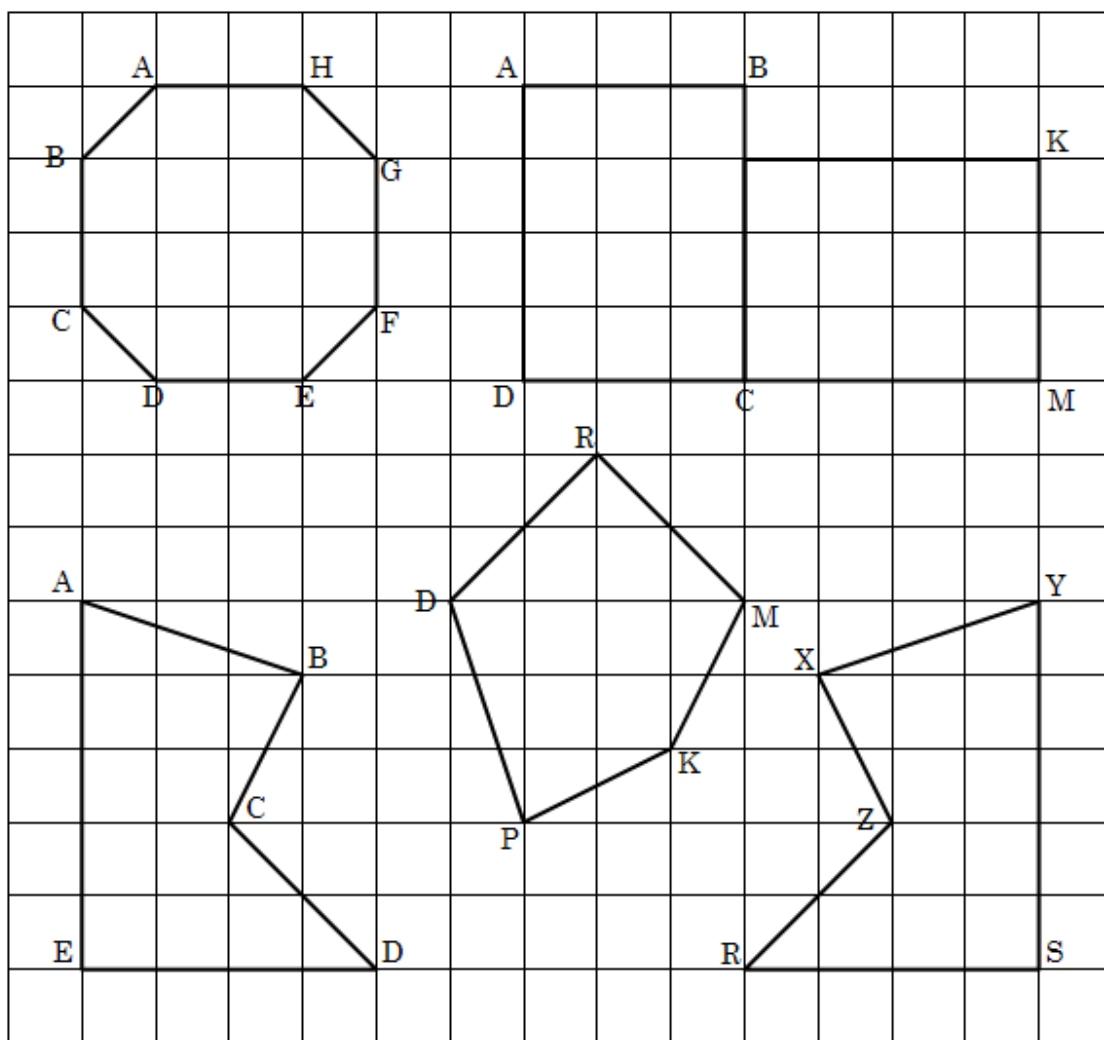

Figure 2.51

⁶This content is available online at <http://cnx.org/content/m31848/1.1/>.

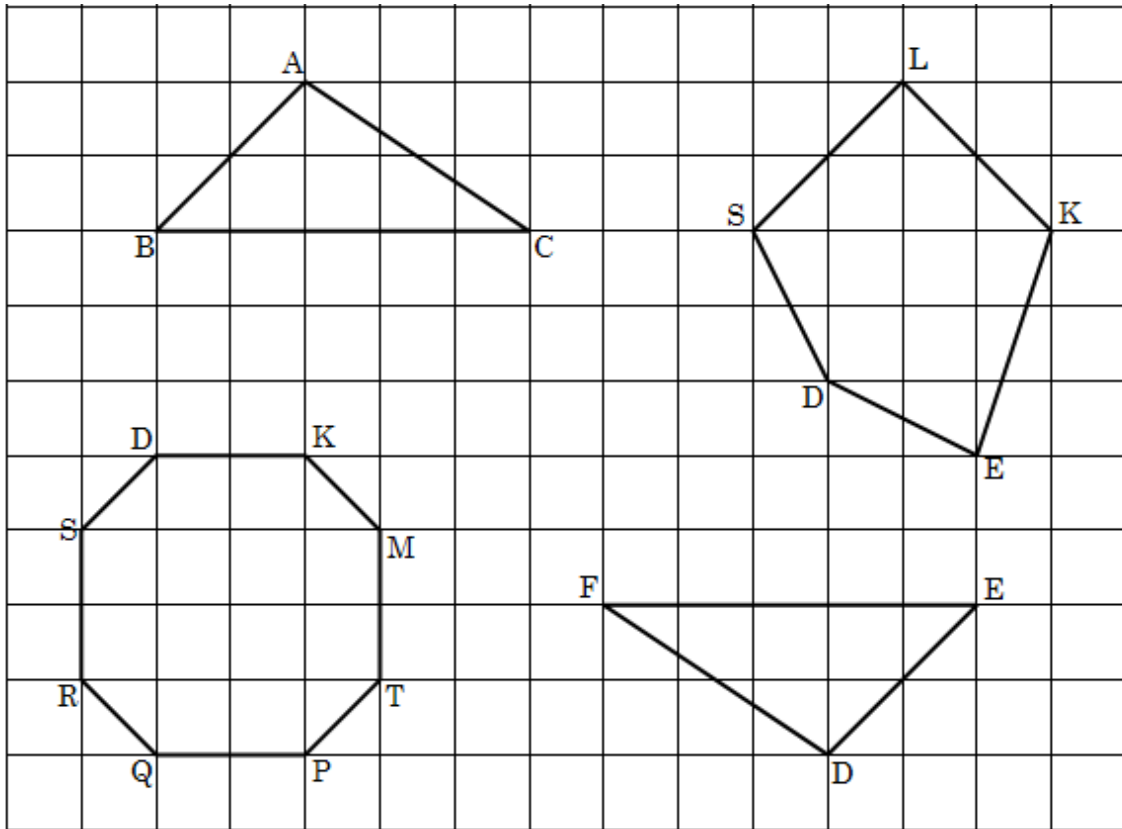

Figure 2.52

2.6.7 A-2

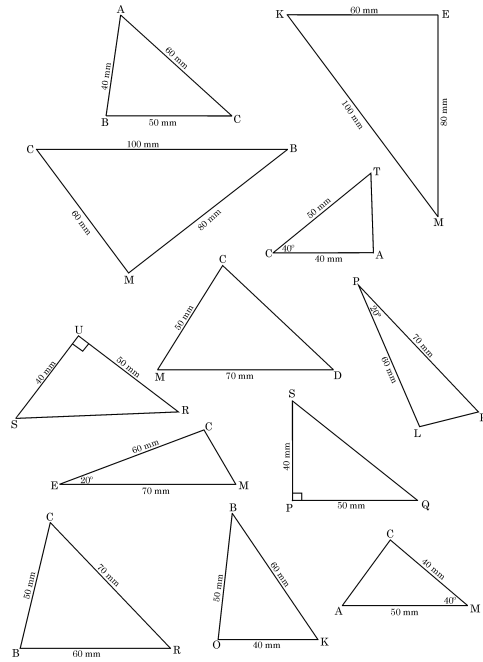

Figure 2.53

2.6.8 A-3

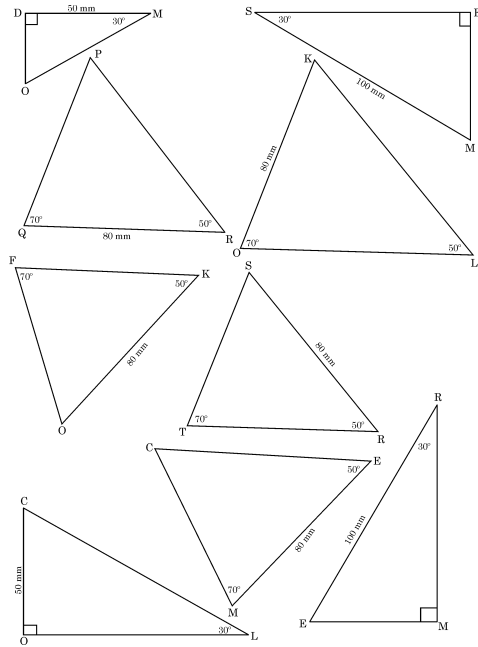

Figure 2.54

2.6.9 A-4

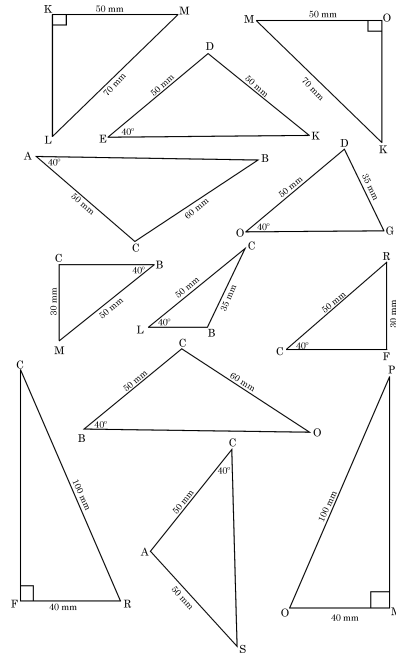

Figure 2.55

2.6.10 A-5

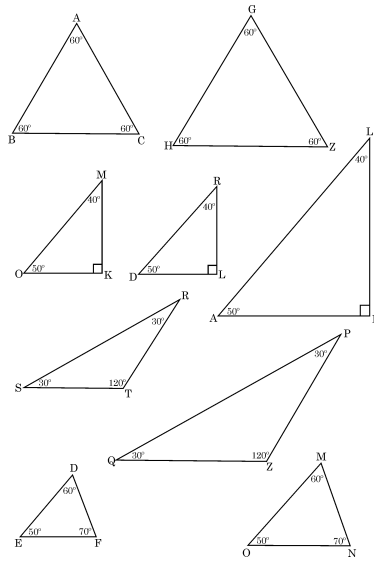

Figure 2.56

2.6.11 A-6

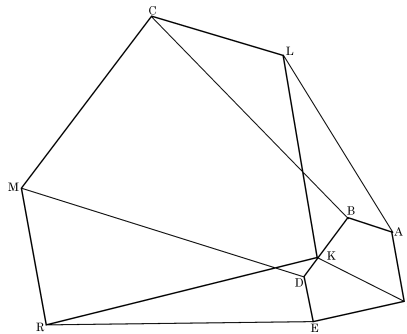

Figure 2.57

2.6.12 A-7

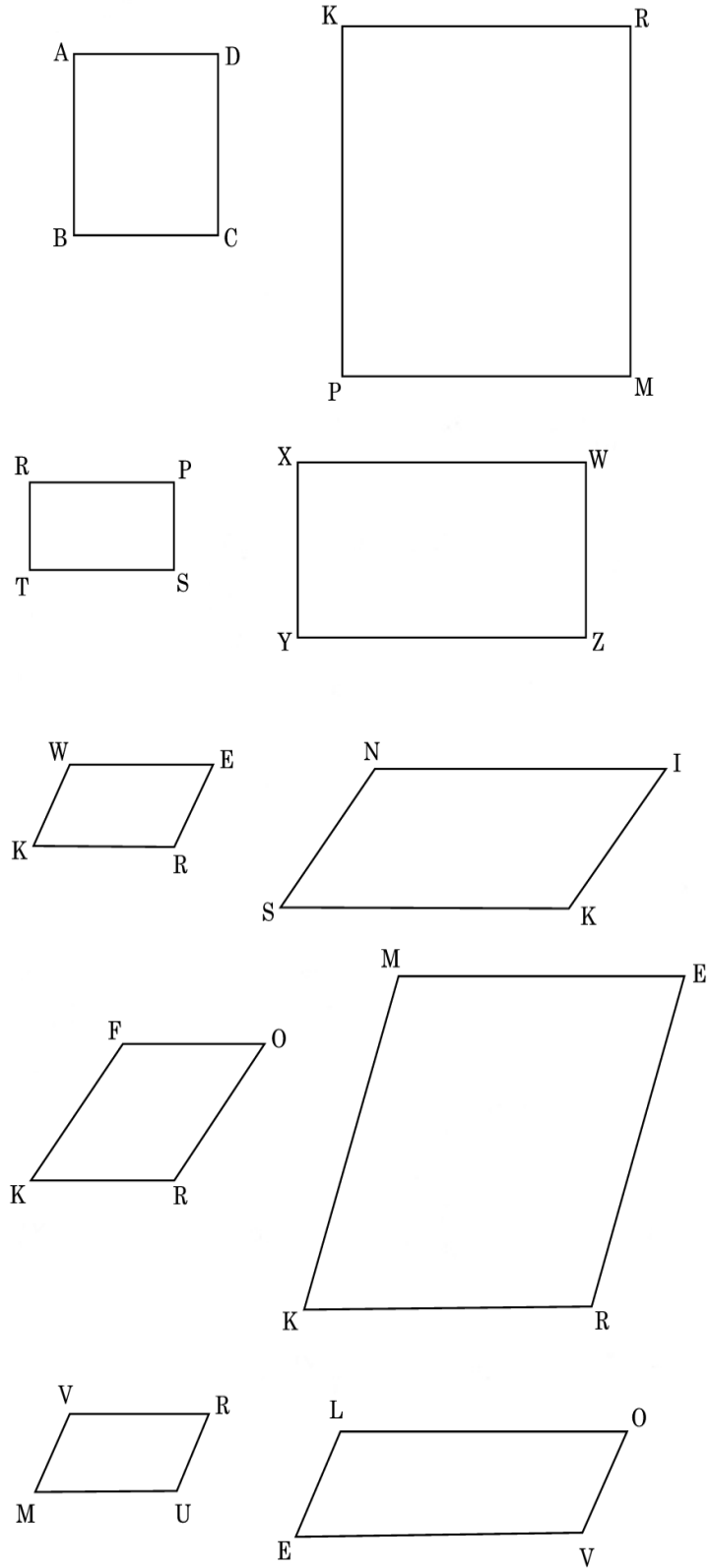

Figure 2.58

Chapter 3

Term 3

3.1 Number patterns¹

3.1.1 MATHEMATICS

3.1.2 Grade 9

3.1.3 NUMBER PATTERNS, GRAPHS, EQUASIONS,

3.1.4 STATISTICS AND PROBABILITY

3.1.5 Module 12

3.1.6 NUMBER PATTERNS

ACTIVITY 1

To use a table to arrange information

[LO 2.1, 2.2]

1. Alice is making necklaces by using triangular motifs that she places on a wire necklet (as shown in Diagram 1 below). Each motif is made from three black beads, six white beads and six coloured beads. It is important that she has the right number of beads of each colour. She wants to make 50 necklaces with black, white and red beads, 40 with black, white and yellow beads, 40 with black, white and blue beads and 30 with black, white and green beads.

¹This content is available online at <<http://cnx.org/content/m31253/1.1/>>.

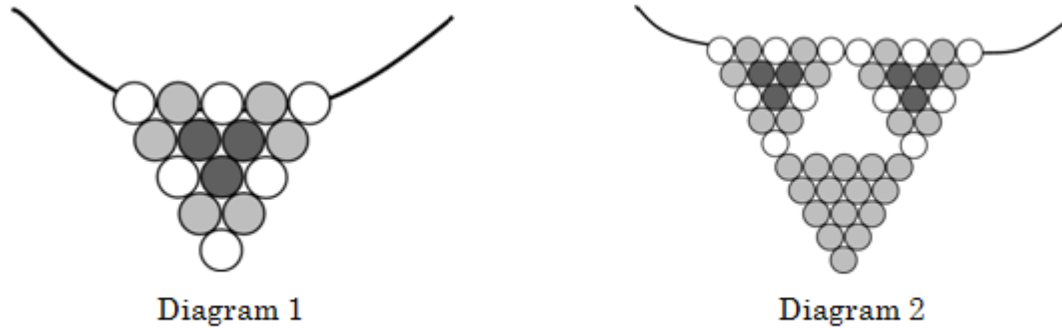

Figure 3.1

Question: Calculate how many beads of each colour she has to buy.

2. She also combines three of these motifs in a bigger necklace (as shown in Diagram 2 above). The two top motifs in each necklace have the same design as before, but the bottom motif is made of 15 coloured beads only. She makes only half as many of these necklaces in each colour as she makes of the smaller necklaces referred to in Question 1.

Question: How many beads of each colour will she need for these necklaces?

3. She finds that the bigger necklaces are very popular, so she decides to use bigger motifs, and to combine more motifs in one necklace. The next two diagrams show her new plans.

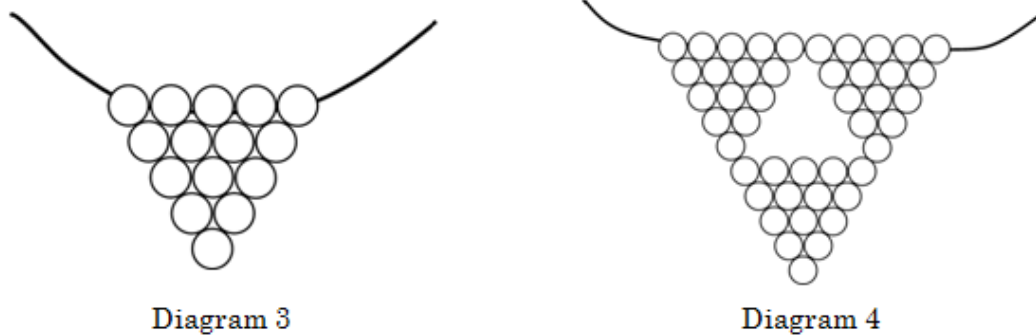

Figure 3.2

Alice wants to use four colours in these motifs. Use the diagram above to make your own four-colour design.

Question: Repeat the calculation exercises above for these necklaces.

4. These triangular motifs can be made larger and larger, of course. Not all of them are suitable for necklaces though!

Exercise: Below you see equilateral triangular Motifs 1 to 4. Draw Motifs 6 and 7 in the same sequence.

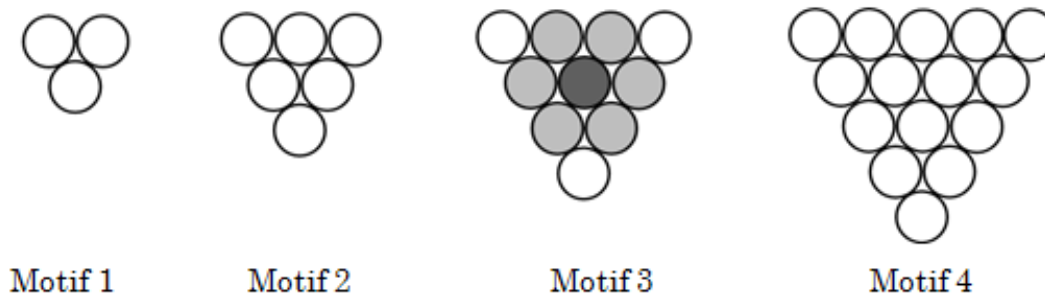

Figure 3.3

The Motif 3 above has 1 black bead, 3 white beads and six red beads. You will need to refer to it in problem 6 below.

5. Data gathering: The beads in the motifs have a diameter of 1 cm each. Thus, the surrounding triangle in Motif 1 in the sequence has a side length of 2 cm. Complete the table below by referring to the triangles above as well as the ones you have drawn.

Side length of triangle in centimetres	2	3	4	5	6	7	8
Number of beads per triangle	3	6	10				
Perimeter of triangle	6	9					

Table 3.1

6. Investigation: Alice makes her necklaces by combining triangular motifs as in diagrams 2 and 4. She uses the 10-bead motifs (Motif 3). The smallest necklace has one motif (size 1) and the next necklace has three motifs (size 2) with a triangular gap in the middle. Visualise the next sizes (3, 4, etc) of the necklaces (or draw them) and complete the table below. Try to complete the last column as well.

Size of necklace	1	2	3	4	5	X
Number of triangular motifs	6	10				
Number of triangular spaces						
Number of beads on each side of triangular motif						
Total number of beads in necklace						
Number of black beads						
Total perimeter of pendant with 1 cm-diameter beads	9					

Table 3.2

7. Investigation: Do the same for the next table, if Alice now uses the 15-bead motif that we saw in the very first diagram.

Size of necklace	1	2	3	4	5	x
Number of triangular motifs	1	3				
Number of triangular spaces	0	1				
Number of beads on each side of triangular motif	5	10				
Total number of beads in necklace	15	45				
Number of black beads	3	9				
Total perimeter of pendant with 1 cm-diameter beads	12	27				

Table 3.3

Putting information in a table makes it much easier to notice the patterns that the numbers form. That is why tables are very often used to arrange information. You will see many cases where tables are used in mathematics. Use a table whenever you think that it will be helpful when you are working on a problem.

ACTIVITY 2

To investigate relationships between variables

[LO 2.1, 2.6]

Mr and Mrs Peters want to hire a caravan for their holiday. They made enquiries about the cost from three caravan hire firms. Now they need to decide which caravan to hire, and for how long. We will help them decide. Here are the verbal descriptions of the details they obtained from the firms:

- Away-van: Their caravans cost R750 per day.
- Best Caravans charge a rental fee of R1 200, with a daily charge of R360.
- Car-a-holiday: They rent out a caravan for R950, with a R540 daily charge.

1. Arranging data: Complete the following table from the descriptions above.

Number of days:	1	2	3	4	5	6	7	8	9	10	11
Away-van:	R750										
Best Caravans:	R1560	R1920									
Car-a-holiday:	R1490	R2030									

Table 3.4

2. Can you tell from the table which option will be the best depending on the length of the holiday? Write a short summary of your conclusions.
3. This is a flow diagram for the Car-a-holiday prices. Calculate the missing values for the blocks:

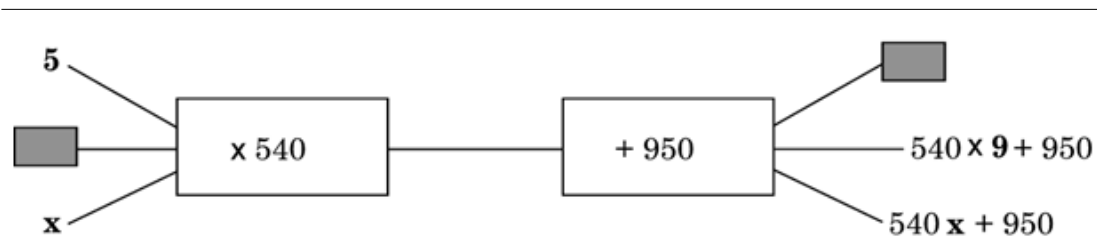

Figure 3.4

4. Make flow diagrams for the other two options.

5. Bradley is holidaying in America. He would like to hire a cell phone. He has investigated three different offers. Below are the following: A description in words of offer 1, A table of values for offer 2 and A flow diagram for offer 3.

There are spaces for you to complete the other two offers in each case. After you have completed the six, do the next exercise.

Verbal descriptions:

Offer 1: "ADVANCED MOBILE! Lowest call cost! Popular handset! \$20 when you sign, plus 60 cents per call!"

Offer 2: "GENIE RENTALS

Offer 3: "HI-PRO

Tables:

Number of calls:	10	20	30	40	50	60
Advanced mobile:						
Genie rentals:	\$24	\$38	\$52	\$66	\$80	\$940
Hi-Pro:						

Table 3.5

Flow diagrams:

Advanced mobile:



Genie rentals:



Hi-Pro:

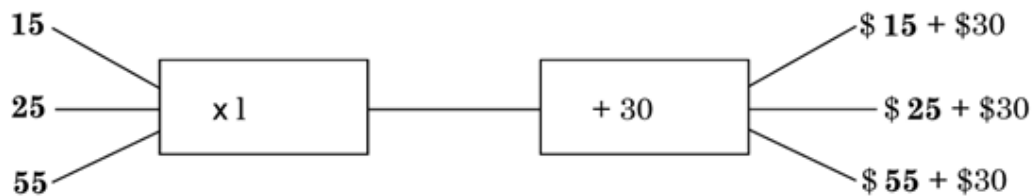

Figure 3.5

6. Write down which offer Bradley should choose under which circumstances. You don't know whether he wants to use the phone for two days, two weeks or two months, for example. You also don't know how many calls he wants to make.

7. Now write down which one of the three representations was the most useful to you when you answered question 6. Give complete reasons for your statements.

ACTIVITY 3

To create a model to explain relationships

[LO 2.2, 2.3]

Olga likes chocolate-covered raisins. She has been making a list of the contents of the packets that she has been buying. She always buys from the same shop, but sometimes she buys small packets (50g), sometimes medium (100g) and sometimes large (200g) packets.

She has made a table of the facts she has discovered.

Packet size	50g	100g	200g
Average number of raisins	78	153	304
Cost per packet	R3,80	R7,40	R14,50

Table 3.6

Olga contacted the manufacturers and found out from them that part of the price is for the packaging and the other part is for the contents. The packet cost is very similar for the three sizes, and the greatest part of the price is for the raisins. The unit cost of the contents stays the same regardless of the size of the packet.

Another interesting fact she found is that the factory controls very carefully that the packets do not contain too few raisins. They aim to have at least 75 in the 50g packet, 150 in the 100g packet and 300 in the 200g packet. To be sure that this happens, they are careful to make the packet of raisins with the same final mass. They also put a few extra raisins in most packets. Olga was very happy to tell them that her figures agreed with their standards.

From the given information, find out how much the raisins (excluding the packaging) cost. Give your answer in rand per kilogram.

3.1.7 Assessment

LO 2
Patterns, Functions and AlgebraThe learner will be able to recognise, describe and represent patterns and relationships, as well as to solve problems using algebraic language and skills.
We know this when the learner:
2.1 investigates, in different ways, a variety of numeric and geometric patterns and relationships by representing and generalising them, and by explaining and justifying the rules that generate them (including patterns found in nature and cultural forms and patterns of the learner's own creation);
2.2 represents and uses relationships between variables in order to determine input and/or output values in a variety of ways using:
2.2.1 verbal descriptions;
2.2.2 flow diagrams;
2.2.3 tables;
2.2.4 formulae and equations;
2.3 constructs mathematical models that represent, describe and provide solutions to problem situations, showing responsibility toward the environment and health of others (including problems within human rights, social, economic, cultural and environmental contexts);
2.4 solves equations by inspection, trial-and-improvement or algebraic processes (additive and multiplicative inverses, and factorisation), checking the solution by substitution;
2.5 draws graphs on the Cartesian plane for given equations (in two variables), or determines equations or formulae from given graphs using tables where necessary;
2.6 determines, analyses and interprets the equivalence of different descriptions of the same relationship or rule presented:
<i>continued on next page</i>

2.6.1 verbally;
2.6.2 in flow diagrams;
2.6.3 in tables;
2.6.4 by equations or expressions;
2.6.5 by graphs on the Cartesian plane in order to select the most useful representation for a given situation;
2.8 uses the laws of exponents to simplify expressions and solve equations;
2.9 uses factorisation to simplify algebraic expressions and solve equations.

Table 3.7

3.1.8 Memorandum

Discussion

Answers:

1 480 black; 960 white; 300 red; 240 yellow; 240 blue and 180 green

2 480 black; 960 white; 675 red; 540 yellow; 540 blue and 405 green

5.

Side length of triangle in centimetres	2	3	4	5	6	7	8
Number of beads per triangle	3	6	10	15	21	28	36
Perimeter of triangle	6	9	12	15	18	21	24

Table 3.8

6.

Size of neck-lace	1	2	3	4	5	x
Number of triangular motifs	1	3	6	10	15	$x+(x-1)+(x-2)+\dots+1$
Number of triangular spaces	0	1	3	6	10	$(x-1)+(x-2)+\dots+1$
Number of beads on each side of triangular motif	4	8	12	16	20	4x

continued on next page

Total number of beads in necklace	10	30	60	100	150	$10\{x+(x-1)+(x-2)+\dots+1\}$
Number of black beads	1	3	6	10	15	$(x-1)+(x-2)+\dots+1$
Total perimeter of pendant with 1cm-diameter beads	9	21	33	45	57	$3(4x-1)$

Table 3.9

7.

Size of necklace	1	2	3	4	5	x
Number of triangular motifs	1	3	6	10	15	$x+(x-1)+(x-2)+\dots+1$
Number of triangular spaces	0	1	3	6	10	$(x-1)+(x-2)+\dots+1$
Number of beads on each side of triangular motif	5	10	15	20	25	$5x$
Total number of beads in necklace	15	45	90	150	225	$15\{x+(x-1)+(x-2)+\dots+1\}$
Number of black beads	3	9	18	30	45	$3\{x+(x-1)+(x-2)+\dots+1\}$
Total perimeter of pendant with 1cm-diameter beads	12	27	42	57	72	$3(5x-1)$

Table 3.10

ACTIVITY 2

1.

Number of days:	1	2	3	4	5	6	7	8	9	10	11
Away-van:	R750	1500	2250	3000	3750	4500	5250	6000	6750	7500	8250
Best Caravans:	R1560	R1920	2280	2640	3000	3360	3720	4080	4440	4800	5160
Car-a-holiday:	R1490	R2030	2570	3110	3650	4190	4730	5270	5810	6350	6890

Table 3.11

If they want to go for only three days then Away-van is the cheapest. Best Caravans is the cheapest for holidays of from 4 to 11 days. Car-a-holiday is never the cheapest option, even if the holiday is longer than 11 days.

3. Input = 9; output = $540 \times 5 + 950 = 3\ 650$
- 4.

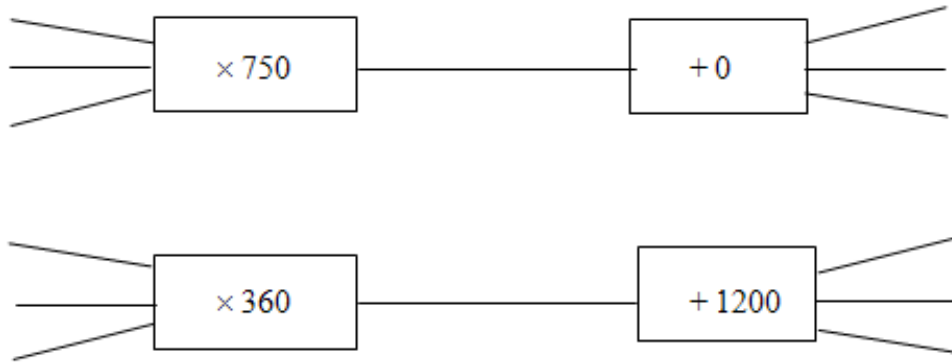

Figure 3.6

5. Bradley and his phones:

- Offer 1: “ADVANCED MOBILE! Lowest call cost! Popular handset! \$20 when you sign, plus 60 cents per call!”
- Offer 2: “GENIE RENTALS has a basic charge of only \$10, and calls cost \$1,40 each.”
- Offer 3: “HI-PRO for mobile hire! We charge only \$1,00 per call! Sign up for \$30.”

Tables:

Number of calls:	10	20	30	40	50	60
Advanced mobile:	\$26	\$32	\$38	\$44	\$50	\$56
Genie rentals:	\$24	\$38	\$52	\$66	\$80	\$94
Hi-Pro:	\$40	\$50	\$60	\$70	\$80	\$90

Table 3.12

- Flow diagrams:
- Advanced mobile:

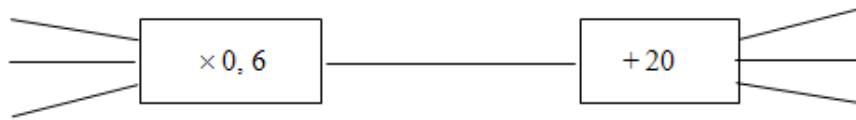

Genie rentals:



Hi-Pro:

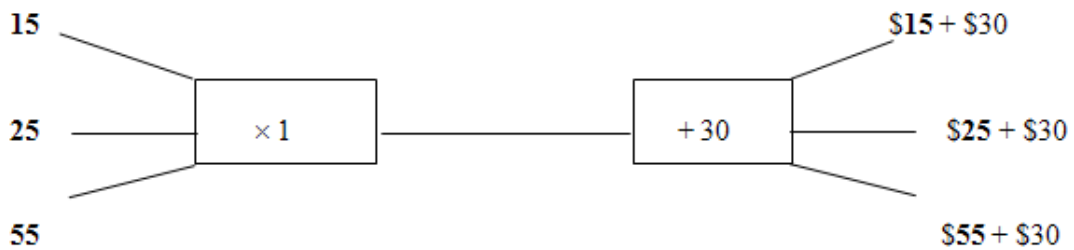

Figure 3.7

6. Genie Rentals is the cheapest as long as he won't want to make more than about 10 calls. Hi-Pro is never the cheapest. He is likely to get the best deal from Advanced Mobile if he wants to stay for a while.

7. It is easier to compare costs from the table. A graph would be easier still.

ACTIVITY 3

- From the table, the unit cost of raisins plus packaging varies between 4,77 cents and 4,87 cents.
- As the packaging is supposed to be very cheap, the raisins will be somewhat less than R73 per kilogram.

TEST

- This unit has no test.

3.2 Understanding what graphs tell us²

3.2.1 MATHEMATICS

3.2.2 Grade 9

3.2.3 NUMBER PATTERNS, GRAPHS, EQUATIONS,

3.2.4 STATISTICS AND PROBABILITY

3.2.5 Module 13

3.2.6 UNDERSTAND WHAT GRAPHS TELL US

Are graphs just pretty pictures?

ACTIVITY 1

To study a number of graphs with the aim of understanding what they can tell one

[LO 1.3, 5.5]

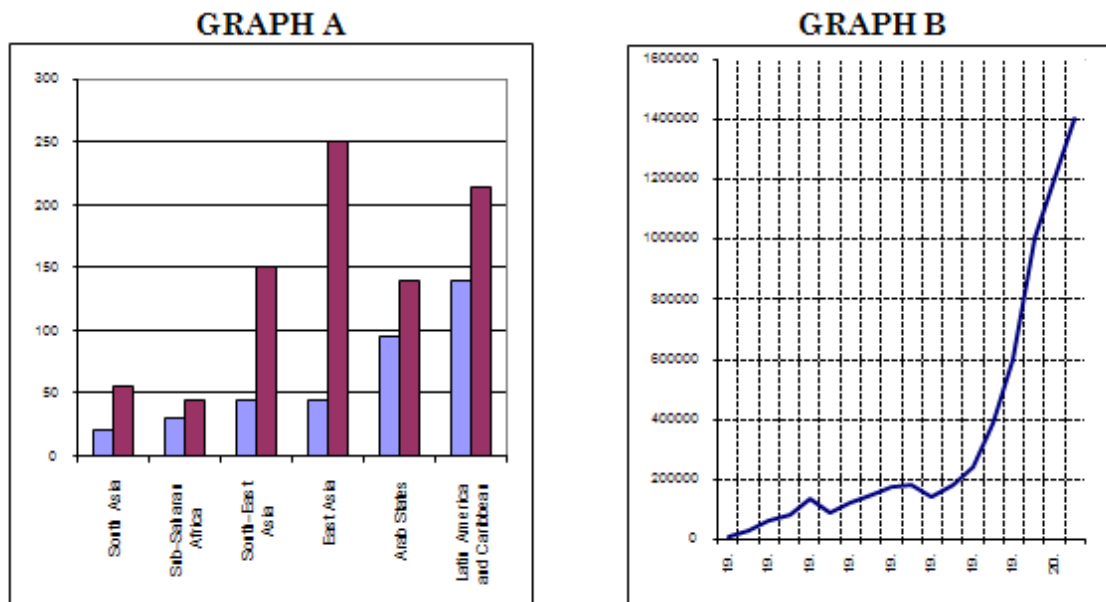

Figure 3.8

Graph A shows how the number of TV sets owned by every 1 000 people changed between 1985 and 1995 in six different regions in the world. For example, South Asia had 20 TV sets per 1 000 people in 1985, and 55 sets per 1 000 people in 1995.

Graph B shows, on the vertical axis, the number of people in prison in the United States of America in the years shown on the horizontal axis. For example, in 1940 there were 135 000 people in prison.

- Work in pairs; one person works with graph A, answering question 1 below, and the other with Graph B and question 2. Give the reason or explanation for each of your answers.

²This content is available online at <<http://cnx.org/content/m31265/1.1/>>.

1 Study **graph A**, then write down answers and explanations to these questions:

- 1.1 Which region had the smallest number of TV sets per 1 000 in 1985?
- 1.2 Which region had the highest number of TV sets per 1 000 in 1995?
- 1.3 In which region did the number of TV sets per 1 000 increase the most?
- 1.4 Is there a region where the number of TV sets per 1 000 has decreased?
- 1.5 Compare Sub-Saharan Africa with the Arab States and discuss the change in the number of TV sets per 1 000 in these two regions.

1.6 Draw a similar graph showing two other regions: South Africa and the United States of America. Make up the figures.

2 Now study **graph B** and answer these questions:

2.1 From the graph, try to estimate how many people were in prison in these years:

a) 1930 b) 1950 c) 1995

2.2 In 1980, were there more than or fewer than 200 000 people in jail?

2.3 There is a dip in the graph just after 1940. What do you think the graph is telling us?

2.4 Say roughly how many years it took for the prison population to double from what it was in 1950

2.5 How long did it take the prison population to double from what it was in 1985?

2.6 Would you say that the number of people in jail in the USA keeps increasing? Give reasons.

2.7 From the information in the graph make a prediction about the number of people in USA jails in the future.

3 In Geography, an interesting kind of graph is a *section* drawing. This shows how the height of the land varies over a straight line between two places. Here is one for the line between Bottelaryberg and Papegaaiberg, two hills near Stellenbosch. All the measurements are in metres. From this we can see (on the left) that Bottelaryberg is about 470 m above sea level, and Papegaaiberg about 255 m above sea level. Walking in a straight line from Bottelaryberg you come to sharp dip, after about 2,5 km, and then, for the next half a kilometre, you go over a little rounded rise.

- This is a very useful graph for road planners, as it shows the steepness of the terrain.

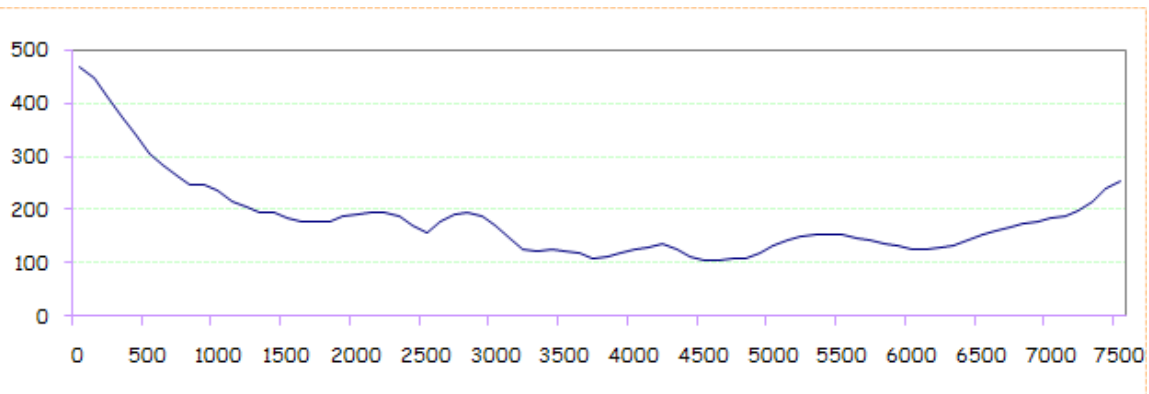

Figure 3.9

- We can clearly see that the descent from the top of Bottelaryberg is very steep, as the line drops sharply over about 750 m. But, if you were on top of Papegaaiberg, and going down in the direction of Bottelaryberg, it would take 1,5 km to drop the same distance, making the route much less steep.

- Steepness (also called *slope*) is measured as the vertical distance divided by the horizontal distance, namely: $\frac{\text{verticalchange}}{\text{horizontalchange}}$ or $\frac{\text{rise}}{\text{run}}$ in engineer-speak. As you will see, this is exactly how one measures the *gradient* of a graph.

3.1 What is the height above sea level of the spot exactly halfway between the two hills?

3.2 What is the difference in height of the two hills?

3.3 What is the lowest spot, according to the graph?

4 Look for graphs to study. You can look in newspapers, magazines (car, sports and financial magazines) and textbooks in other subjects. If you have an atlas, you will usually see graphs there. If possible, bring these graphs to school to discuss in class. If the graph is about something that you find interesting, then you can ask yourself some questions like the ones in the exercises above.

- When you learn about statistics in a later module, you will study more (and different) graphs.
- **ACTIVITY 2**

To be able to understand, construct and use the Cartesian system of coordinates

[LO 1.4, 1.7, 2.3, 3.7]

1. Arranging seats in the school hall:

The diagram shows a small school hall. The blocks are chairs for the audience. There are three doors (marked X) – one at the back and two in the middle of the sides. From the stage you can see the Left half of the chairs and the Right half of the chairs on either side of the passage. The other passage separates the front chairs (with Soft seats) from the back chairs (with Hard seats).

The rows are numbered from the centre of the hall 1 to 6 to the front, 1 to 6 to the back, 1 to 6 to the right and 1 to 6 to the left, as viewed from the stage.

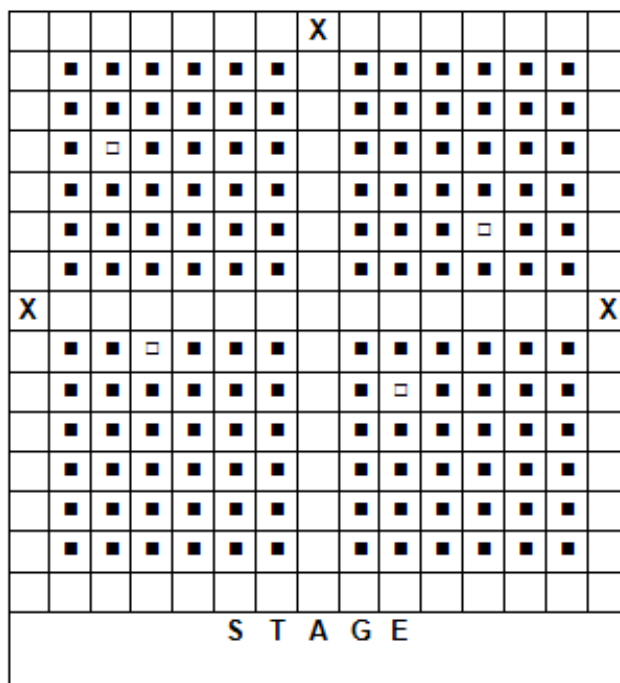

Figure 3.10

- The four tickets belonging to the four white blocks in the diagram are labelled L4S1, L5H4, R2S2 and R4H2. As you can see, the first letter tells us whether the seats are to the left or to the right. The number after this letter tells how far from the centre passage the seat is. The next letter tells us whether the seat is a soft seat in the front half or a hard seat in the back, and the last number says how far it is from the passage that runs across the hall.

1.1 How many people can be seated in the hall?

1.2 If you have to show the guests to their seats, you must know which one of the white blocks goes with which ticket. Fill the correct labels in on the diagram.

1.3 In the same way, find and label these seats: R6S6; R5H1; L1S1; L6S1; L2S5; L3H3; R1H1.

1.4 If the school needed to put 25 more chairs into the hall, they could be put in the passage. Without changing the numbers already on the chairs, how would you number the 25 extra chairs? Can you use the letters now? What about the numbers?

2. Numbering the points on graph paper:

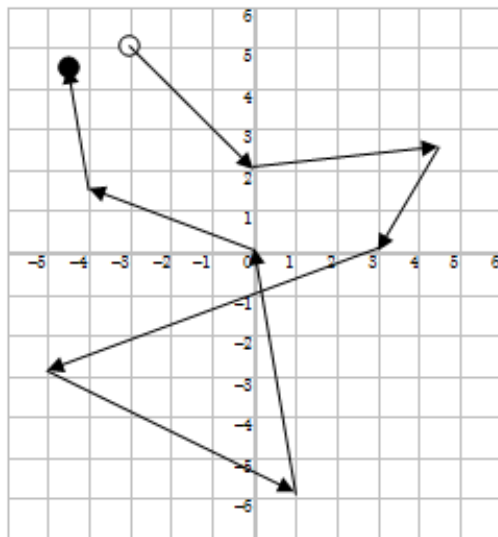

Figure 3.11

This diagram is called the Cartesian plane.

The numbers refer to the places where the lines cross, NOT the spaces in between.

The horizontal dark line is called the x-axis and the vertical dark line is the y-axis. The place where they cross is called the origin. Its coordinates are $(0 ; 0)$. Coordinates are always written as two numbers separated by a semi-colon, in brackets

The first number in the brackets always refers to the numbers on the x-axis, and the second number refers to the number on the y-axis.

- Let us play follow-the-leader. On the diagram alongside, $(-3 ; 5)$ is marked with a white circle. From there the arrow points to $(0 ; 2)$. The next arrow leads to $(4\frac{1}{2} ; 2\frac{1}{2})$ and then to $(3 ; 0)$, $(-5 ; -3)$, $(1 ; -6)$, $(0 ; 0)$, $(-4 ; 1\frac{1}{2})$ and $(-4\frac{1}{2} ; 4\frac{1}{2})$, ending at the black circle.

Make sure that you understand how coordinates work before you continue.
The axes (the dark lines) divide the Cartesian plane into four quadrants.

Second quadrant	First quadrant
Third quadrant	Fourth quadrant

Figure 3.12

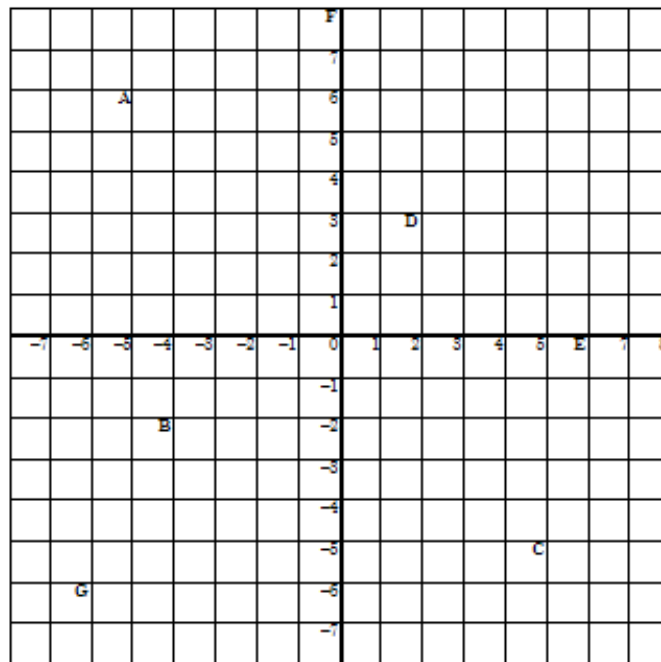

Figure 3.13

2.1 Write down the coordinates of the crosses marked A to G on the diagram. Use brackets and semicolons and put the two numbers in the correct order.

2.2 Find the following dots on the diagram and carefully join them in order. What does your picture remind you of?

$(-4 ; 0)$ $(-4 ; -6)$ $(-3 ; -6)$ $(-3 ; -2)$ $(-2 ; -2)$ $(-2 ; -6)$ $(-1 ; -6)$ $(-1 ; -2)$ $(3 ; -2)$ $(3 ; -6)$ $(5 ; -6)$ $(5 ; 0)$ $(7 ; 0)$ $(7 ; 2)$ $(5\frac{1}{2} ; 2)$ $(4\frac{1}{2} ; 4)$ $(4 ; 2)$ $(-4 ; 2)$ $(-6 ; 4)$ $(-4 ; 0)$

- René Descartes (pronounced *daycar*) was born in France in 1596, and died of pneumonia when he was 54. At the time he lived, there were many wars in Europe and he became a soldier and took part in several campaigns. He was not only a mathematician, but also studied physics (particularly optics), astronomy, meteorology and anatomy as well as the theory of music. While working on some difficult mathematical problems, he developed the system of numbering graph paper so that geometry could be combined with algebra to solve the problems. This is why the design of the diagram above is called the *Cartesian plane*.

ACTIVITY 3

To use a table of values to draw a graph on the Cartesian plane

[LO 1.3, 2.1, 2.2, 2.5]

1 In this table there is a relationship between a number in the top row of the table (input value) and the one directly below it (output value). There are some missing numbers and these gaps have been labelled *a*, *b* and *c*.

1.1 Study the first seven columns of numbers in the table until you can see the pattern, and write down the rule used to calculate the output value from the input value. Now use this rule to fill in the gaps by calculating what *a*, *b* and *c* have to be if they follow the same rule.

Input value	1	2	3	4	5	6	7	9	12	<i>c</i>
Output value	17	22	27	32	37	42	47	<i>a</i>	<i>b</i>	77

Figure 3.14

1.2 We now take the pairs of numbers in each column to make up sets of coordinates. They always look like this:

(input value ; output value),
with the input value in the first position.

- Here are the first two sets of co-ordinates: $(1 ; 17)$ and $(2 ; 22)$. Write down the rest in the same way, including the last three with your calculated values instead of *a*, *b* and *c*.

1.3 Make a dot on this Cartesian plane for every set of coordinates you have found from the table.

You should have ten dots, and they should lie in a straight line.

Use a ruler to draw the line.

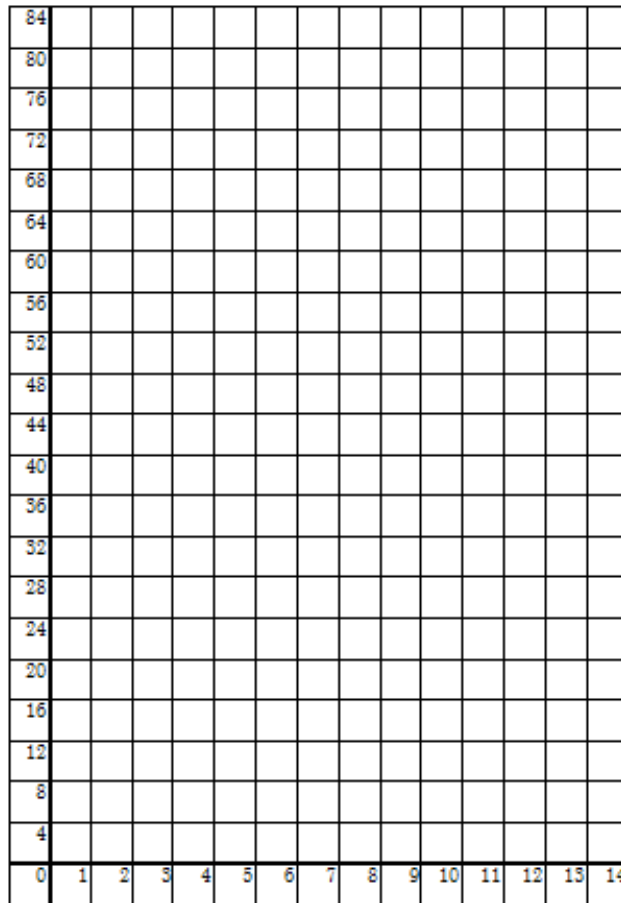

Figure 3.15

2 The next table shows the charges for a gardener who charges R35 per hour or part-hour.

Hours worked	1	1,5	2	2,5	3	4	5	8
Total amount	35	70	70	105	105	140	175	280

Table 3.13

2.1 Write down your explanation of the fact that there are two R70's in the second row, and also two R105's.

2.2 Use squared paper similar to the previous exercise. Carefully plan what the numbers on the axes must be to fit the values in this table, and plot the coordinates from the table as dots.

2.3 For this graph it is wrong to try joining the dots with a straight line. This graph has to go up in steps. The reason is that the gardener will charge the same amount for working, say, two hours 10 minutes, two hours 25 minutes, two hours 40 minutes and three hours. Complete the graph by making the appropriate shape of the steps.

2.4 From the completed graph, read off how much it will cost if the gardener works for $6\frac{1}{2}$ hours.

3.2.7 Assessment

Learning outcomes(LOs)
LO 1
Numbers, Operations and RelationshipsThe learner will be able to recognise, describe and represent numbers and their relationships, and to count, estimate, calculate and check with competence and confidence in solving problems
Assessment standards(ASs)
We know this when the learner:
1.2 recognises, uses and represents rational numbers (including very small numbers written in scientific notation), moving flexibly between equivalent forms in appropriate contexts;
1.3 solves problems in context including contexts that may be used to build awareness of other learning areas, as well as human rights, social, economic and environmental issues such as:
1.3.1 financial (including profit and loss, budgets, accounts, loans, simple and compound interest, hire purchase, exchange rates, commission, rental and banking);
1.3.2 measurements in Natural Sciences and Technology contexts;
1.4 solves problems that involve ratio, rate and proportion (direct and indirect);
1.7 recognises, describes and uses the properties of rational numbers.
LO 2
Patterns, Functions and AlgebraThe learner will be able to recognise, describe and represent patterns and relationships, as well as to solve problems using algebraic language and skills.
We know this when the learner:
2.1 investigates, in different ways, a variety of numeric and geometric patterns and relationships by representing and generalising them, and by explaining and justifying the rules that generate them (including patterns found in nature and cultural forms and patterns of the learner's own creation;
<i>continued on next page</i>

2.2 represents and uses relationships between variables in order to determine input and/or output values in a variety of ways using:
2.2.1 verbal descriptions;
2.2.2 flow diagrams;
2.2.3 tables;
2.2.4 formulae and equations;
2.3 constructs mathematical models that represent, describe and provide solutions to problem situations, showing responsibility toward the environment and health of others (including problems within human rights, social, economic, cultural and environmental contexts);
2.4 solves equations by inspection, trial-and-improvement or algebraic processes (additive and multiplicative inverses, and factorisation), checking the solution by substitution;
2.5 draws graphs on the Cartesian plane for given equations (in two variables), or determines equations or formulae from given graphs using tables where necessary;
2.6 determines, analyses and interprets the equivalence of different descriptions of the same relationship or rule presented:
2.6.1 verbally;
2.6.2 in flow diagrams;
2.6.3 in tables;
2.6.4 by equations or expressions;
2.6.5 by graphs on the Cartesian plane in order to select the most useful representation for a given situation;
2.8 uses the laws of exponents to simplify expressions and solve equations;
2.9 uses factorisation to simplify algebraic expressions and solve equations.

Table 3.14

LO 3
Space and Shape (Geometry)The learner will be able to describe and represent characteristics and relationships between two-dimensional shapes and three-dimensional objects in a variety of orientations and positions.
We know this when the learner:
3.7 uses various representational systems to describe position and movement between positions, including:
<ul style="list-style-type: none"> • ordered grids;
3.7.2 Cartesian plane (4 quadrants)3.7.3 compass directions in degrees;3.7.4 angles of elevation and depression.
<i>continued on next page</i>

LO 4
MeasurementThe learner will be able to use appropriate measuring units, instruments and formulae in a variety of contexts
We know this when the learner:
4.1 solves ratio and rate problems involving time, distance and speed;
4.4 uses the theorem of Pythagoras to solve problems involving missing lengths in known geometric figures and solids.
LO 5
Data HandlingThe learner will be able to collect, summarise, display and critically analyse data in order to draw conclusions and make predictions and to interpret and determine chance variation.
We know this when the learner:
5.1 poses questions relating to human rights, social, economic, environmental and political issues in South Africa;
5.2 selects, justifies and uses appropriate methods for collecting data (alone and/or as a member of a group or team) which include questionnaires and interviews, experiments, and sources such as books, magazines and the Internet in order to answer questions and thereby draw conclusions and make predictions about the environment;
5.3 organises numerical data in different ways in order to summarise by determining:
5.3.1 measures of central tendency;
5.3.2 measures of dispersion;
5.4 draws a variety of graphs by hand/technology to display and interpret data including:
5.4.1 bar graphs and double bar graphs;

Table 3.15

3.2.8 Memorandum

Discussion

Basic graphical literacy

The first part serves only to familiarise learners with the general appearance of a graph. Help them understand that the legends to the left and bottom of the graph contain meaningful information.

In this section the importance of correct and adequate labelling of graphs has not been emphasized in the learner's module. This is mainly to keep the graphs legible. The teacher should point out that titles and other explanatory labels are necessary, and at appropriate times discuss the value of and need for annotation of graphs. Learners should always label their own graphs properly.

It will be difficult, as it often is with graphs, to be completely accurate in readings taken from the graph. The main idea is that they learn where and how readings can be taken, and not to want perfectly accurate answers. It is important that they be encouraged to motivate their answers – this will lead them to try and make logical sense of the work, and not to only guess.

1.1 South Asia 1.2 East Asia 1.3 East Asia 1.4 No

1.5 Roughly speaking, the increase was about in the same ratio – each increased by about 50% of what it had been.

1.6 SA started from a very low base (almost no TV sets) and increased fast. The US started with many TV sets and could therefore not increase so much.

- In question 1.6 learners should get some input from the educator, as they might not be old enough to have the necessary experience.
- 2.1 (a) 50 000 – 60 000 (b) about 125 000 (c) nearly a million
 2.2 more than 2.3 (see below) 2.4 About thirty years
 2.5 Less than ten years 2.6 Yes – the graph goes up to the right.
 Question 2.3 – think Second World War!
 Question 2.7: The main idea is that it is impossible for the graph to keep on going upwards forever.
 Question 3 uses a graph from an area in the Western Cape – maybe it will be possible to find something close to the home range of the learners.
 3.1 Between 100 m and 110 m
 3.2 About 215 m
 3.3 Nearly 3 000 m from Papegaaiberg
- The teacher can help a great deal to make learners more graphically literate by looking for graphs to show and discuss, and to encourage learners to do the same. An atlas usually has graphs of various kinds. Later in the module when other graphical methods are discussed, atlases can once again be used for additional examples.

Cartesian planes

- Graph paper is very expensive. Two sheets of squared paper is included at the end of this section, instead of in the learner's module. The teacher can make photocopies of them whenever necessary
 - Most learners understand coordinate systems well after a bit of practice. The hardest thing to grasp can be that the integers refer to where the *lines* are, and not to the space in between. This is essential to knowing how to deal with fractions of a unit. It is effort well-repaid to make sure they get this point mastered. Point out that it works like a ruler.
1. $4 \times 36 = 144$
 2. R4H2 ; L5H4 ; L4S1 ; R2S2 (Please check these answers with the learner's module)
 3. Answer not included – left as an exercise for the teacher.
 4. The letters are less useful – but this is the opportunity to bring in zero (for the chairs in the passages) and negative numbers for the seats to the left and to the front.
 There is a great deal of terminology coming in at this stage – the more the educator uses the correct terms, the more familiar the learners will become with them.
 1. A (-5 ; 6) B (-4 ; -2) C (5 ; -5) D (2 ; 3)
 E (6 ; 0) F (0 ; 8) G (-6 ; -6)
 2. Something looking like a dog should emerge.
 Tables and graphs
- When working with tables, it is important to take note of the order and pattern of the top row when trying to determine a pattern for the bottom row.
- 1.1 (The formula is $5x + 12$) $a = 57$; $b = 72$; $c = 13$
 1.2 (1 ; 17) (2 ; 22) (3 ; 27) (4 ; 32) (5 ; 37) (6 ; 42) (7 ; 47) (9 ; 57) (12 ; 72) (13 ; 77)
 2. This situation illustrates a stepped graph
 2.1 1,5 hours is part of two hours and 2,5 hours is part of 3 hours.
 2.2 Plot only dots, and don't join them.
 2.4 R245
 Homework

Hours	0,5	1	1,5	2	2,5	3	3,5	4	4,5	5	5,5	6	6,5	7	7,5	8
A	125	210	295	380	465	550	635	720	805	890	975	1060	1145	1230	1315	1400
B	145	230	315	400	485	570	655	740	825	910	995	1080	1165	1250	1335	1420
C	175	175	325	325	475	475	625	625	775	775	925	925	1075	1075	1225	1225
D	200	200	400	400	600	600	800	800	1000	1000	1200	1200	1400	1400	1600	1600

Table 3.16

Here is a table of the values to be plotted. Important: This is also a stepped graph.

3.3 Understanding how equations are represented on a graph³

3.3.1 MATHEMATICS

3.3.2 Grade 9

3.3.3 NUMBER PATTERNS, GRAPHS, EQUASIONS,

3.3.4 STATISTICS AND PROBABILITY

3.3.5 Module 14

3.3.6 UNDERSTANDING HOW EQUATIONS ARE REPRESENTED ON A GRAPH

ACTIVITY 1

To understand how equations can be represented on a graph

[LO 2.2, 2.5, 2.6]

Example: The equation $y = 3x + 2$ tells one how the values of x and y are connected – it shows the *relationship* between two variables, x and y .

- For example, if x is 5, then y can be calculated from $3 \times 5 + 2$, giving 17. So, we *substitute* the value 5 for the x , and complete the calculation.

x	-2	5	8
y	-4	17	26

Figure 3.16

- The table shows some of the answers.

The point of making a table is that it gives us coordinates, which we can plot on a set of axes. From these we can draw a graph, which is a picture of the relationship between x and y .

³This content is available online at <<http://cnx.org/content/m31268/1.1/>>.

1 In a group of 4 or 5 learners, complete the tables from the equations below. Each one should do a different table, and then discuss the answers and copy the others' tables into your book. Below each table is a set of axes on which to draw the graph. All of these graphs will be straight lines, so you may connect the points you plot from each table.

1.1 $y = -4x + 3$

x	-2	-1	0	1	2
y					

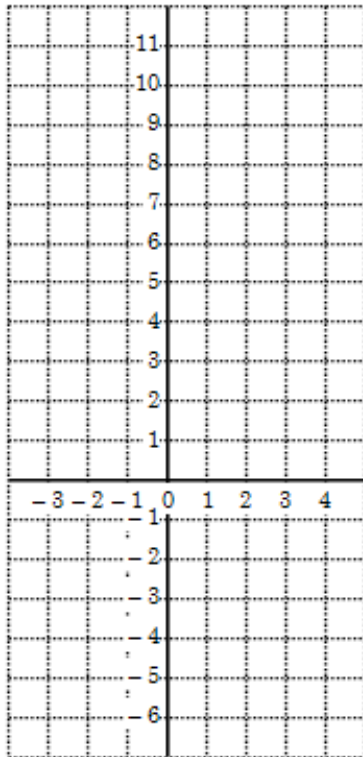

1.2 $y = 3x - 4$

x	-1	0	2	3
y				

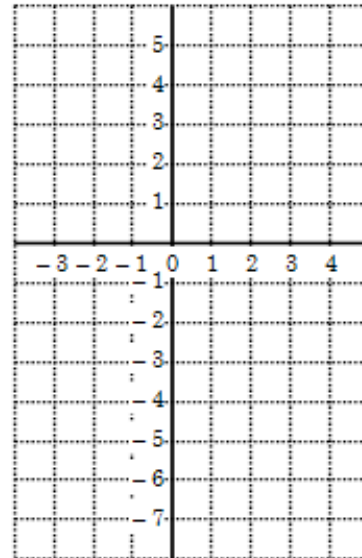
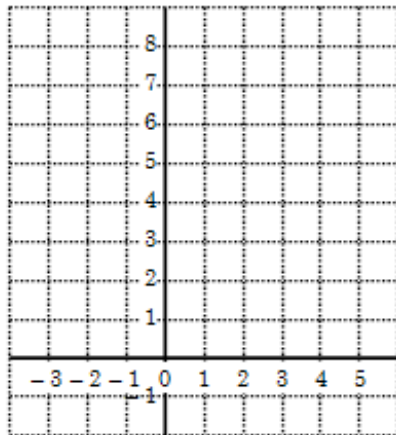

Figure 3.17

1.3 $y = x + 5$

x	-2	-1	0	1	2	3
y						



1.4 $y = 4$ (!!)

x	-2	-1	0	2	3
y					

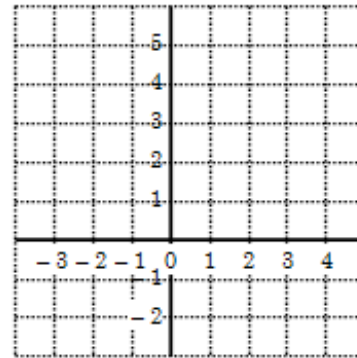
Figure 3.18

1.5 $y = \frac{1}{2}x + 1$

x	-4	-2	0	2	4	6
y						

1.6 $y = -2x$

x	-2	3
y		

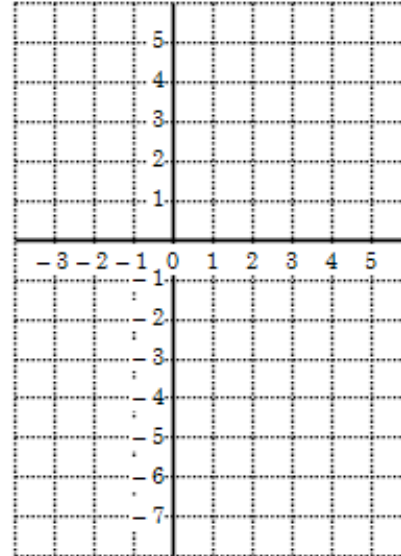
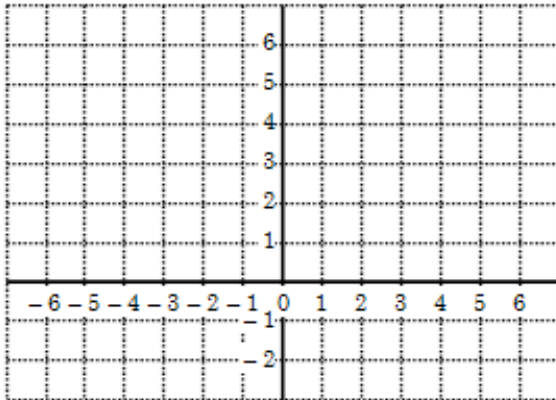

Figure 3.19

2 In your group, discuss what you see in your graphs. Compare the graph with the equation. Here are a few suggestions for you to investigate:

2.1 What does the coefficient of x in the equation do to the graph? What happens when the coefficient is negative?

2.2 In 1.6 the table has only two columns. Is it necessary to have more than two columns if you know that the graph will be a straight line?

2.3 Compare 1.1 and 1.5 to see if you can find out what the constant does to the graph.

- The table summarises how equations, tables and graphs agree with one another. You have to **memorise this information** – you can't work correctly with graphs if you don't know the words

Equation:	x	y
Equation:	Independent variable	Dependent variable
Flow diagram::	Input value	Output value
Table:	First row	Second row
Coordinates:	1st coordinate	2nd coordinate
Graph:	x- axis	y- axis
Graph:	Horizontal axis	Vertical axis

Table 3.17

ACTIVITY 2

To understand and apply all the characteristics of the straight-line graph

[LO 2.5]

1 In the previous activity you used equations to make tables from which graphs were drawn. One can also draw a graph from an equation without making a table. As we saw in graph 1.6 above, if we know that we have to draw a straight line, then two points on the graph paper are sufficient to enable us to draw the line. We don't need a table if we have the equation of the straight line.

- In this section we will refer repeatedly to the six graphs in the previous exercise.

- First we have to examine the structure of the equation:

$y = mx + c$ is the *standard form* of the equation:

- y is on the left of the equal sign, and y has no coefficient (which is the same as saying that its coefficient is **1**, which we don't write)
- After the equal sign there may be one or two terms (compare equations 1.5 and 1.6 above). If there are two terms, then the term in x is written first – the x may have any number as a coefficient: positive, negative or fractional.
- In the standard form we write an m to stand for the coefficient. If the coefficient is **1**, then again we don't write it.
- The c stands for a *constant* – any number that is not a variable: it can also be negative, positive or fractional.
- If we write $y = mx + c$ then this is the *general equation* for *all* straight lines. But $y = -3x + 2$ is the *defining equation* for a *specific* straight line.

- Writing equations in the standard form: First an example:

$6x + 2y - 1 = 0$ Keep the term in y on the left; move the other two to the right.

$2y = -6x + 1$ Now make the coefficient of $y = 1$ by dividing all the terms by 2.

$y = -3x + \frac{1}{2}$ This the standard form.

Here $m = -3$ and $c = \frac{1}{2}$.

- Now you practise some – also write down what m and c are, as above.

1.1 $2x + y = 3$

1.2 $3y - 9 = 6x$

1.3 $3x = 6y$

1.4 $2y - 8 = 0$

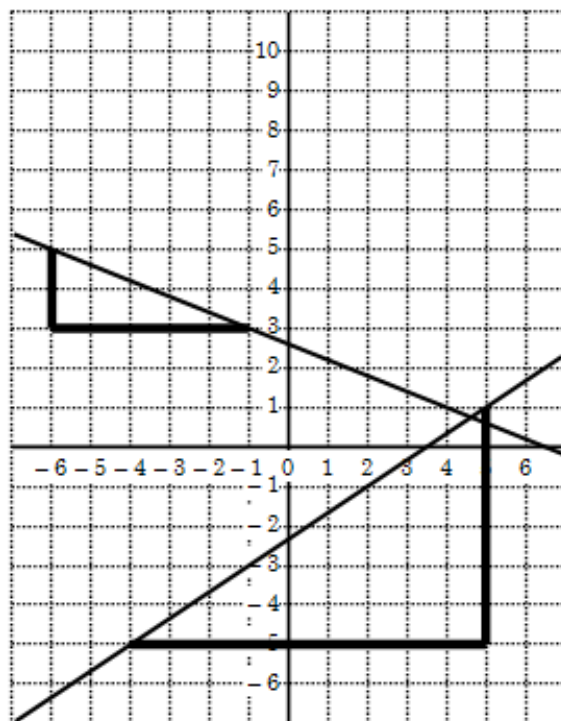

Figure 3.20

2 Understanding the gradient.

Previously we mentioned that the steepness of a graph can be calculated – this is very easy if the graph is a straight line, because it is equally steep everywhere – we say that the gradient of a straight-line graph remains constant.

Study the values of m in the six graphs in the previous exercise

If your work is correct, you will have noticed that the graphs slope up to the right where m is positive, and the graphs slope down to the right where m is negative.

In other words, m tells us about the gradient. (What do you think happens in $y = 4$, the odd one out?)

- With m positive, the number of units the line goes up for every unit it goes right gives us m (the gradient). When m is negative, we count how many units the line goes down for every unit it goes right.
- Here are two examples. By completing right-angled triangles in a convenient position on the lines in the graph, we can easily calculate the two gradients, as follows:
- For the top line: $m = -\frac{2}{5}$, because the line goes down to the right, we know the gradient is negative; 2 is the height of the triangle and 5 is its length.

- For the bottom line: $m = +\frac{6}{9} = \frac{2}{3}$, with 6 the height of the triangle, and 9 its length. We don't write the +, and we simplify the fraction.

2.1 Now go back to the previous six graphs and do the same so that you can confirm that the m in the equation agrees with the gradient you calculate from the graph itself. Also notice how the size of m tells you how steep the graph is.

3 Finding out where the graph cuts the y -axis (called the y -intercept):

- If you study the equations of the six graphs, you will notice that the constant term (c) in the standard form tells us exactly where the graph cuts the y -axis!
 - For example, in $y = 3x - 4$, the y -intercept is at -4 on the y -axis.
 - Confirm that this is true for all six graphs.
- Now we have a method for drawing graphs from an equation in the standard form. We don't have to make a table – we simply use the y -intercept (given to us by c), and the gradient (given by m).
 - On the graph paper, mark the y -intercept. Now use the gradient in the form of a fraction; if it is a whole number, then write it with **1** as a denominator. From the y -intercept, count as many units to the right as the denominator. From there count as many units as the numerator *up*, if m is positive, or *down*, if m is *negative*. Here are two examples:

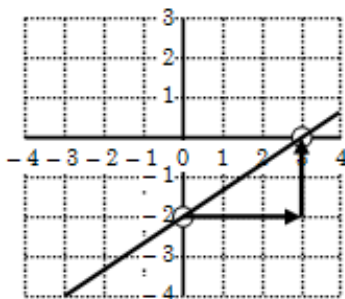

Figure 3.21

(a) $y = \frac{2}{3}x - 2$

The y -intercept is -2 , marked on the y -axis with a circle. The gradient is $\frac{2}{3}$, so we move from the circle three units to the right, and then 2 units up (not down – the gradient is positive). Another circle marks the spot we end up at. And now we draw the straight line through these two spots.

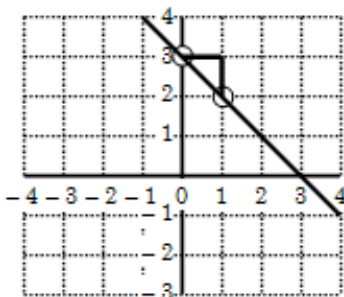

Figure 3.22

(b) $y = -x + 3$

- The y -intercept is 3, marked by a circle. The gradient is -1 , which we change to $-\frac{1}{1}$. This tells us to move one unit (denominator) to the right and then one unit (numerator) down (not up). We end up at the point $(1; 2)$, marked by a second circle. Draw the line through the two circled points.
- Draw the following graphs using the y -intercept/gradient method you have just studied.

3.1 $y = -3x + 1$

3.2 $y = \frac{1}{3}x - \frac{5}{2}$

3.3 $y = \frac{-3}{4}x$

3.4 $4x - 3y = 5$

4 In problem 3.4 above, you should have written the equation in the standard form to be able to use m and c for the y -intercept/gradient method. This is a lot of extra work.

- There is another way to find the two points needed to be able to draw a straight-line graph. If we can find out where the graph cuts the x -axis as well as the y -axis, then we can simply draw the line through the two intercepts!

	y-intercept	x-intercept
$y = 3x - 4$	$(0; -4)$	$(\frac{1}{3}; 0)$
$y = -4x + 3$	$(0; 3)$	$(\frac{3}{4}; 0)$
$y = \frac{1}{2}x + 1$	$(0; 1)$	$(-2; 0)$

Table 3.18

Going back again to the previous six graph problems, the table shows the x - and y -intercepts for three of them in the form of coordinates.

The important thing to notice is that the y -intercept always has a zero in the position of the x -coordinate, and the x -intercept always has a zero in the position of the y -coordinate.

- This means that if we take the equation as it is and make the x zero and simplify to find the value of y , it will give us the y -intercept. Making the y zero and finding x , gives us the x -intercept. Here is how to do it for the equation $9 - 6x = 3y$ (definitely *not* in the standard form):

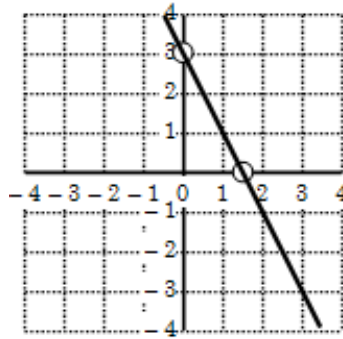

Figure 3.23

- Finding the y -intercept:

- Substitute 0 for x :

$$9 - 6(0) = 3y \quad [U+F05C] \quad 9 - 0 = 3y \quad [U+F05C] \quad 9 = 3y \quad [U+F05C] \quad 3y = 9 \quad [U+F05C] \quad y = 3$$

The y -intercept in coordinate form is $(0; 3)$

- Mark this point on the graph.

- Finding the x -intercept:

- Substitute 0 for y :

$$9 - 6x = 3(0) \quad [U+F05C] \quad 9 - 6x = 0 \quad [U+F05C] \quad 9 = 6x \quad [U+F05C] \quad 6x = 9 \quad [U+F05C] \quad x = \frac{9}{6} = \frac{3}{2}$$

The x -intercept in coordinate form is $(\frac{3}{2}; 0)$

- Mark this point on the graph. Finally draw a line through the two points. Alongside is the sketch.

- This is a very easy and convenient method. If you work carefully and with concentration, it won't easily go wrong. Practise the method on the following equations:

4.1 $4y + 3x = 4$ 4.2 $6y + 15 = 2x$ 4.3 $3x + 4y = 0$

4.4 $3y + 5 = 4x$ 4.5 $2y + 8 = 6x$ 4.6 $4y - 2x - 4 = 0$

Does this method remind you of something?

5 We still have to consider a few special cases. With the equation written in the standard form, we can deduce a great deal about the graph

- The standard form of the straight-line equation is $y = mx + c$, as we know. If c is zero, then the equation becomes $y = mx$; if m is zero, then the equation becomes $y = c$.

- $y = mx + c$, (where neither m nor c is zero), is the equation which produces lines which do not pass through the origin, nor are they horizontal or vertical. The first diagram shows some of these graphs. You can use either the y -intercept/gradient method or the two-intercept method for drawing these graphs.
 - $y = mx$ (c is zero) produces lines which are neither horizontal nor vertical. They do pass through the origin, which is understandable as c is zero, meaning the y -intercept is zero. The second diagram shows a few of these. The y -intercept/gradient method is the simplest for drawing these graphs.
 - $y = c$ is the equation of a horizontal line, as you have already seen. Draw them by drawing a horizontal line through the y -intercept (c).
 - If the equation of the line is $x = k$, where k is a constant, then this is a vertical line with k the x -intercept. Draw them by finding k on the x -axis and drawing a vertical line through that point. The third diagram shows some of the horizontal and vertical graphs.
- With all the advice above, you should be able to figure out the equations of these twelve graphs. If not, the next section will help.

3.3.7 Assessment

LO 2
Patterns, Functions and Algebra The learner will be able to recognise, describe and represent patterns and relationships, as well as to solve problems using algebraic language and skills.
We know this when the learner:
2.1 investigates, in different ways, a variety of numeric and geometric patterns and relationships by representing and generalising them, and by explaining and justifying the rules that generate them (including patterns found in nature and cultural forms and patterns of the learner's own creation;
2.2 represents and uses relationships between variables in order to determine input and/or output values in a variety of ways using:
2.2.1 verbal descriptions;
2.2.2 flow diagrams;
2.2.3 tables;
2.2.4 formulae and equations;
2.3 constructs mathematical models that represent, describe and provide solutions to problem situations, showing responsibility toward the environment and health of others (including problems within human rights, social, economic, cultural and environmental contexts);
<i>continued on next page</i>

2.4 solves equations by inspection, trial-and-improvement or algebraic processes (additive and multiplicative inverses, and factorisation), checking the solution by substitution;
2.5 draws graphs on the Cartesian plane for given equations (in two variables), or determines equations or formulae from given graphs using tables where necessary;
2.6 determines, analyses and interprets the equivalence of different descriptions of the same relationship or rule presented:
2.6.1 verbally;
2.6.2 in flow diagrams;
2.6.3 in tables;
2.6.4 by equations or expressions;
2.6.5 by graphs on the Cartesian plane in order to select the most useful representation for a given situation;
2.8 uses the laws of exponents to simplify expressions and solve equations;
2.9 uses factorisation to simplify algebraic expressions and solve equations.

Table 3.19

3.3.8 Memorandum

Equations and graphs

- From the first exercise on the six equations, the most important teaching points are: the steepness of the slopes (both positive and negative) of the graphs; the y-intercept, and the fact that these can be deduced very easily from the equation in the standard form. The learners should be led to deduce that one needs to know only two points on a straight-line graph to be able to draw the graph.
- As these six graphs are repeatedly used, the educator has to ensure that the learners' work is correct for the subsequent exercises.
- To read the gradient from a right-angled triangle, choose usable corners to draw the two sides from; also the larger the triangle, the more accurate the values.

Graphs from equations

1.1 $y = -2x + 3$; $m = -2$ and $c = 3$

1.2 $y = 2x + 3$; $m = 2$ and $c = 3$

1.3 $y = \frac{1}{2}x$; $m = \frac{1}{2}$ and $c = 0$

1.4 $y = 4$; $m = 0$ and $c = 4$

The gradient is read off from a graph in this section; the learners need to get an intuitive feel for the gradient from looking at it on a graph. Later we calculate it from two given points.

3.1 to 3.4 The memo is left to the teachers ingenuity.

4.1 $(0; 1)$ $(\frac{4}{3}; 0)$

4.2 $(0; -2\frac{1}{2})$ $(7\frac{1}{2}; 0)$

4.3 $(0; 0)$ $(0; 0)$

4.4 $(0; -\frac{5}{3})$ $(\frac{5}{4}; 0)$

4.5 $(0; -4)$ $(\frac{4}{3}; 0)$

4.6 $(0; \frac{1}{2})$ $(-\frac{1}{2}; 0)$

3.4 Finding the equation of a straight line graph from a diagram⁴

3.4.1 MATHEMATICS

3.4.2 Grade 9

3.4.3 NUMBER PATTERNS, GRAPHS, EQUATIONS,

3.4.4 STATISTICS AND PROBABILITY

3.4.5 Module 15

3.4.6 FINDING THE EQUATION OF A STRAIGHT LINE GRAPH FROM A DIAGRAM

ACTIVITY 1

To find the equation of a straight line graph from a diagram
[LO 2.5]

1. If we can find out the values of m and c , then we simply substitute them in the general equation $y = mx + c$ to give us the defining equation of the line. Let's do an example from the given diagram.

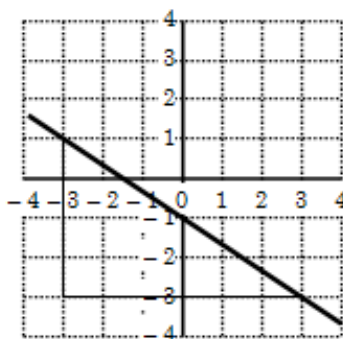

Figure 3.24

To find c is easy as it is the value (positive or negative or zero) where the line cuts the y -axis. Substitute this value (it is -1) for c .

The equation now becomes $y = mx - 1$. To find the gradient (the value of m) we construct the right-angled triangle between two suitable points where the graph goes exactly through corners on the graph paper.

⁴This content is available online at <<http://cnx.org/content/m31271/1.1/>>.

<ul style="list-style-type: none"> Remembering that m is a fraction: 	change in vertical distance
	change in horizontal distance

Table 3.20

- We read off the number of units of the height and the length of the triangle to give us the numerator and denominator respectively
 - We also have to decide whether the sign is negative or positive by looking at which way the line slopes.
 - This gives us: $m = -\frac{4}{6} = -\frac{2}{3}$ (remember to simplify the fraction).
 - This value is now substituted for m in the equation: $y = -\frac{2}{3}x - 1$. This gives us the defining equation of the line in the diagram.
- Going back to the previous section, use this method to find the defining equations of the eight graphs in the first two diagrams.

2 How do we deal with horizontal and vertical graphs? They are the easiest.

- If the line is horizontal, then the equation is $y = c$. We have to replace the c by a value. We read this value off the graph – it is the y -intercept! Substitute this into $y = c$, and you have the defining equation.
 - If the line is vertical, the equation is $x = k$. Find k by reading from the graph where the line cuts the x -axis and substitute this number for k . This gives the defining equation.
- From the previous section, find the equations for the four graphs in the last diagram.

Here are the answers: $y = 1$ and $y = -1,5$ are the two horizontal lines, and $x = -1$ and $x = -2,5$ are the two vertical lines.

3 The following diagrams have a mixture of lines for you to test your skills on.

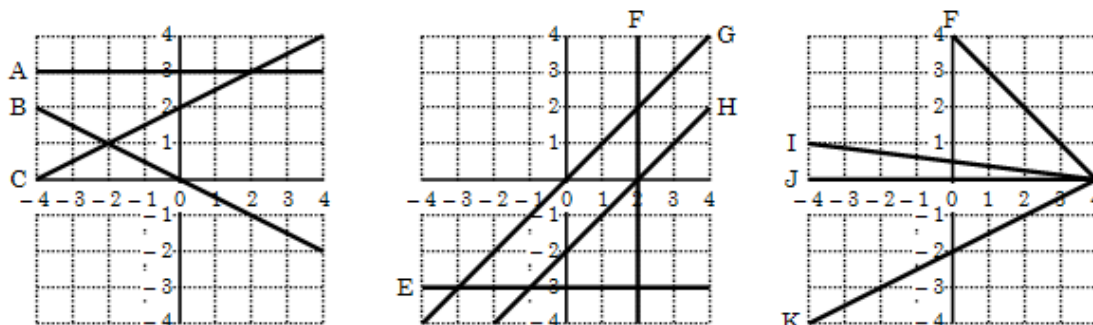

Figure 3.25

4 Did you notice that the gradients (m) of lines G and H are the same? Why is this?

ACTIVITY 2

To calculate the gradient of a straight line from two points on the line

[LO 2.5]

- If you know the coordinates of two points on a certain straight line, then you can draw that line, as you have seen. And from the sketch you can find the gradient as you have already learnt. But it is not necessary to have a graph to find the gradient.
- Here is an example: The points (3 ; -1) and (4 ; 2) are on a certain straight line.
- First we calculate the vertical distance between the two points by subtracting the second point's y -coordinate from the first point's y -coordinate. This is the numerator of the gradient.
- Then we calculate the horizontal distance between the two points by subtracting the second point's x -coordinate from the first point's x -coordinate. This is the denominator of the gradient.
- So, the gradient is: $m = \frac{\text{verticaldistance}}{\text{horizontaldistance}} = \frac{-1-2}{3-4} = \frac{-3}{-1} = 3$
- If you do the subtraction the other way round, then you must do it for both coordinates, like this:

$$m = \frac{\text{verticaldistance}}{\text{horizontaldistance}} = \frac{2-(-1)}{4-3} = \frac{+3}{+1} = 3, \text{ the same answer!}$$

1 On squared paper, mark the two points (3 ; -1) and (4 ; 2) and draw the line. Then use the graphical method you used before to calculate the gradient, to confirm that it agrees with the answer from the calculation above.

2 Below you are given five pairs of coordinates. Calculate the five gradients between the points.

2.1 (2 ; 6) and (4 ; 4)

2.2 (1 ; 2) and (-2 ; -1)

2.3 (0 ; 0) and (1 ; 5)

2.4 (-1 ; 4) and (5 ; 4)

2.5 (7 ; 0) and (7 ; -3)

ACTIVITY 3

To graphically solve two linear equations simultaneously

[LO 2.5]

1 Solve the following five sets of equations simultaneously (you can refer to the chapter where you learnt to do this).

1.1 $y = \frac{1}{2}x + 2$ and $y = 3$

1.2 $y = x$ and $y = -3$

1.3 $y = x - 2$ and $y = -3$

1.4 $y = -x + 4$ and $y = 0$

1.5 $y = \frac{1}{2}x - 2$ and $y = 0$

2 Look at the diagrams in the previous exercise and write down the coordinates of the points where the following lines cross:

2.1 A and C

2.2 E and G

2.3 E and H

2.4 J and L

2.5 K and J

3 Study these answers together with the equations for lines A to L that you found in problem three of the previous section.

- An example:
- Line **J** above has the equation $y = 0$, and for line **I** you should have found the equation $y = -\frac{1}{8}x + \frac{1}{2}$. (This equation can also be written as $x + 8y = 4$. Confirm that this is so by writing $x + 8y = 4$ in the standard form.)
- When we solve these two equations simultaneously, we substitute from $y = 0$ into $x + 8y = 4$.

So, $x + 8(0) = 4$
 [U+F05C] $x + 0 = 4$
 [U+F05C] $x = 4$

The solution is $(4; 0)$. Checking this with the graph, we see that the lines I and J do indeed intersect at the point $(4; 0)$.

- Confirm that your answers are correct by comparing the answers you found when solving the equations *algebraically*, and those found by solving them *graphically*.

Source:

New Scientist, 27 April 2002 for Graphs A and B.

3.4.7 Assessment

LO 2
Patterns, Functions and AlgebraThe learner will be able to recognise, describe and represent patterns and relationships, as well as to solve problems using algebraic language and skills.
We know this when the learner:
2.1 investigates, in different ways, a variety of numeric and geometric patterns and relationships by representing and generalising them, and by explaining and justifying the rules that generate them (including patterns found in nature and cultural forms and patterns of the learner's own creation;
2.2 represents and uses relationships between variables in order to determine input and/or output values in a variety of ways using:
2.2.1 verbal descriptions;
2.2.2 flow diagrams;
2.2.3 tables;
2.2.4 formulae and equations;
2.3 constructs mathematical models that represent, describe and provide solutions to problem situations, showing responsibility toward the environment and health of others (including problems within human rights, social, economic, cultural and environmental contexts);
2.4 solves equations by inspection, trial-and-improvement or algebraic processes (additive and multiplicative inverses, and factorisation), checking the solution by substitution;
2.5 draws graphs on the Cartesian plane for given equations (in two variables), or determines equations or formulae from given graphs using tables where necessary;
2.6 determines, analyses and interprets the equivalence of different descriptions of the same relationship or rule presented:
<i>continued on next page</i>

2.6.1 verbally;
2.6.2 in flow diagrams;
2.6.3 in tables;
2.6.4 by equations or expressions;
2.6.5 by graphs on the Cartesian plane in order to select the most useful representation for a given situation;
2.8 uses the laws of exponents to simplify expressions and solve equations;
2.9 uses factorisation to simplify algebraic expressions and solve equations.

Table 3.21

3.4.8

3.4.9 Memorandum

2.1 $m = -1; c = 1$

$$y = -x + 1$$

2.2 $m = -1,5; c = -1,5$

$$y = -1\frac{1}{2}x - 1\frac{1}{2}$$

2.3 $m = \frac{5}{6}; c = -0,4$

$$y = \frac{5}{6}x - 0,4$$

2.4 $m = 2; c = -1$

$$y = 2x - 1$$

2.5 $m = -1; c = 0$

$$y = -x$$

2.6 $m = -\frac{2}{3}; c = 0$

$$y = -\frac{2}{3}x$$

2.7 $m = \frac{1}{3}; c = 0$

$$y = \frac{1}{3}x$$

2.8 $m = \frac{2}{3}; c = 0$

$$y = \frac{2}{3}x$$

3. A: $y = 3$

B: $y = -\frac{1}{2}x$

C: $y = \frac{1}{2}x + 2$

D: $x = -1$

E: $y = -3$

F: $x = 2$

G: $y = x$

H: $y = x - 2$

I: $y = -\frac{1}{4}x + \frac{1}{2}$

J: $y = 0$

K: $y = \frac{1}{2}x - 2$

L: $y = -\frac{1}{2}x + 4$

4. The lines are parallel. At this point, depending on the class, the educator may want to introduce the facts that for parallel lines, $m_1 = m_2$, and for perpendicular lines, $m_1 \times m_2 = -1$.

Gradients between two points

2.1 $m = \frac{6-4}{2-4} = \frac{2}{-2} = -1$

2.2 $m = \frac{2-(-1)}{1-(-2)} = \frac{2+1}{1+2} = \frac{3}{3} = 1$

$$2.3 \ m = \frac{5-0}{1-0} = \frac{5}{1} = 5$$

$$2.4 \ m = \frac{4-4}{-1-5} = \frac{0}{-6} = 0$$

$$2.5 \ m = \frac{0-(-3)}{7-7} = \frac{3}{0} \text{ which is undefined.}$$

- Learners often confuse the meanings of the zero numerator and the zero denominator. It is wise to emphasize that a 0 denominator must be dealt with first.

If time allows, ask the learners to sketch the lines above by connecting the two given points and to confirm that their answers are reasonable.

1.1 (2 ; 3)

1.2 (-3 ; -3)

1.3 (-1 ; -3)

1.4 (4 ; 0)

1.5 (4 ; 0)

2.1 (2 ; 3)

2.2 (-3 ; -3)

2.3 (-1 ; -3)

2.4 (4 ; 0)

2.5 (4 ; 0)

3.5 Solving simple problems by forming and solving equations⁵

3.5.1 MATHEMATICS

3.5.2 Grade 9

3.5.3 NUMBER PATTERNS, GRAPHS, EQUATIONS,

3.5.4 STATISTICS AND PROBABILITY

3.5.5 Module 16

3.5.6 SOLVING SIMPLE PROBLEMS BY FORMING AND SOLVING EQUATIONS

ACTIVITY 1

To solve simple problems by forming and solving equations

[LO 2.2, 2.4]

How do we solve this problem?

Jamie's dad is four times as old as Jamie. His father is 40. How old is Jamie?

a) We could think really hard, and try a few guesses. For instance: If Jamie is 1 year old, then his father must be 4. Not correct. What about 2 years old? And so on.

b) Make a table: Complete the empty spaces. Does this help?

Age	1	2	3	4		
Age x 4	4	8	12		28	40

Table 3.22

⁵This content is available online at <<http://cnx.org/content/m31273/1.1/>>.

c) Draw a flow diagram: Is this useful?

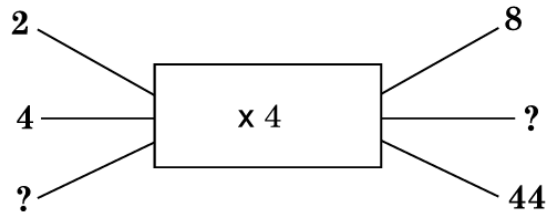

Figure 3.26

- As you can see, there is not much difference between the three methods – you can use any one that suits you. But they are not really very useful, because you have to do a lot of guessing. If the problems become very difficult, these methods become impossible to use.
- So we will use a better way.
- The way to do this problem is to make an equation from the information, and then to solve the equation and use the solution to write down an answer.
- Making equations is not very easy to start with, but it gets a lot easier with practice.
- An equation needs an equal sign as well as a variable (we usually use x , but it can be any letter).

Jamie's dad is four times as old as Jamie. If his father is 40, how old is Jamie?

- This is the general form of the equation:
- Four times Jamie's age = father's age, which is 40.
- The question asks Jamie's age; so we **let Jamie's age be x** .
- Now the equation becomes: $4x = 40$
- and this asks us to find a number which gives 40 when multiplied by 4. If we divide 40 by 4, we get 10. So x must be 10, and therefore Jamie is ten years old. It is easy to see that this answer is correct.

A problem for you to do: *Leon has 48 marbles. Amy has only a third as many as Leon; how many does she have?* Use the last method.

The way you should set out your answer is:

State what the variable represents.

- Write an equation using the variable.
- Solve the equation.
- Write down the solution, namely what the value of the variable is.
- Write down the answer to the problem in words.

Please note that the first and last steps are in ordinary words, and the middle step(s) in algebra.

Exercise:

Find the answers to the following problems:

1. Mr Jacobs has R295,45 in his pocket. Mrs Jacobs has R55,30 less than her husband in her purse. How much money does she have in her purse?

2. I think of a number. I multiply it by 7 and divide the answer by three. I get 49. What was the number I first thought of? Remember to check your answer.

3. In America Joanie buys an item that is marked \$5,75. She works out that it would be R41,69 when she converts the dollars to rand. What is the rand/dollar exchange rate she used?

ACTIVITY 2

To develop effective methods for solving more complicated equations

[LO 2.3, 2.4]

- We will be doing more word problems, but we have to concentrate more on the algebra in our solutions. Make sure that you know exactly what each of the steps means and why it is done.
- Some of the following problems are followed by the solutions. But try to find the answer without looking ahead. Then compare your answer and the way you set it out with the answer.

1. If I treble the price of the CD I bought, and then add R90 to the answer, I get the price of the R495 portable CD player I bought at the same time. How much did the CD cost? How much did I spend at the time?

- Solution: Cost of CD \times 3 plus R90 = price of CD player

Let x be the price of the CD.

$$x \times 3 + 90 = 495 \text{ Translate the words into algebra}$$

$$3x + 90 = 495 \text{ simplify}$$

$$3x = 495 - 90 \text{ Do the same } (-90) \text{ on both sides of the equal sign}$$

$$3x = 405 \text{ simplify}$$

$$x = 405 \text{ [U+FOB8] } 3 \text{ Do the same ([U+FOB8] } 3) \text{ on both sides of the equal sign}$$

$$x = 135 \text{ simplify}$$

The CD cost R135.

I spent $R135 + R495 = R630$ altogether.

2. Mrs Williams is a supervisor in a factory. Devon Jones has just been appointed as a trainee supervisor at a weekly wage of R900. She has heard that if R535 is subtracted from her weekly wage, then the remaining amount is exactly half of the new man's weekly wage. Mrs Williams is concerned that she is not earning as much as the less experienced young man. Is she right to worry? Hint: Let y be Mrs Williams's wage.

3. There is a number which is 6 bigger than another number. The sum of the two numbers is 28. What is the number?

- Solution:

$$(\text{A number}) + (\text{the number} - 6) = 28$$

Let the number be x ; then the other number is $x - 6$

$$x + (x - 6) = 28 \text{ Translate into algebra}$$

$$x + x - 6 = 28 \text{ Remove brackets}$$

$$2x - 6 = 28 \text{ simplify}$$

$$2x = 28 + 6 \text{ Add 6 to each side}$$

$$2x = 34 \text{ simplify}$$

$$x = 34 \text{ [U+FOB8] } 2 \text{ Divide each term by 2}$$

$$x = 17 \text{ simplify}$$

The number is 17

Check the answer!

4. Alan and his sister walk straight to school every morning. In the afternoon Alan walks straight home again, but his sister always walks home past her friend's house; this route is twice as long as the route Alan takes home. Together their morning and afternoon distances add up to $1\frac{1}{2}$ kilometre. How far is their house from the school?

It is important to be able to translate the problem into an algebraic equation, and it is also important to be able to do the algebra necessary to solve the equation, and so to solve the problem. We will give that some attention now. Here are the steps in the solution to problem 3 given above.

- First we remove brackets and simplify: $x + (x-6) = 28$ $x + x - 6 = 28$
- Then we make sure all the terms with the variable are on the left of the equal sign, and all the terms without are on the right of the equal sign, by adding or subtracting terms on both sides as necessary, and simplifying: $2x - 6 = 28$ $2x = 28 + 6$ $2x = 34$
- If the variable has a numerical coefficient, we divide both sides by it, and simplify: $x = 17$ [U+FOB8]

We are using all the skills we learned when we simplify e x expressions.

Practise these skills on the following algebraic equations:

5. (a) $5x = 35$ (b) $4x = 22$ (c) $3x - 90 = 0$ (d) $\frac{1}{2}x = 21$

6 (a) $5x + 15 = 35$ (b) $8 + 4x = 22$ (c) $3x - 90 = -60$ (d) $\frac{1}{2}x + 3 = 15$

7 (a) $5x + 15 = 2x$ (b) $8 + 4x = 22 - 2x$ (c) $3x - 90 = x$ (d) $\frac{1}{2}x + 3 = 4 - \frac{1}{2}x$

8 (a) $5(x + 1) = 20$ (b) $8 + 4(x - 1) = 0$ (c) $x(x + 3) = x^2 + 6$ (d) $\frac{1}{2}(4x + 6) = 1$

9 (a) $2(x + 1) = x + 2$ (b) $2(x + 3) = 2x + 6$ (c) $3 - 2x = -2(1 + x)$

Now we must make sense of the solutions we found in these equations.

Here are some answers:

8 (a) $x = 3$ (b) $x = -1$ (c) $x = 2$ (d) $x = -1$

- These are acceptable answers.
- They give the value of the variable (x), which makes the equation true.

9. (a) $x = 0$ This is also an acceptable answer.
 (b) $2x + 6 = 2x + 6$ [U+F05C] $2x - 2x = 6 - 6$ [U+F05C] $0 = 0$

- This answer does not give us a single value of x .
- But the statement is true: zero **is** equal to zero.
- When we get an answer stating an obvious truth, like $12 = 12$ or $-3 = -3$, etc., then we know that any value of the variable will make the equation true.
- So the answer to give: x can take any value.

(c) $3 - 2x = -2 - 2x$ [U+F05C] $-2x + 2x = -2 - 3$ [U+F05C] $0 = -5$

- This answer does not give a value for x .
- The statement is in fact untrue. Zero is **not** equal to negative five.
- When we get an answer which is untrue, like $5 = -5$ or $2 = -9$, etc., then we know that no value of the variable will make the equation true.
- So we give the answer: *There is no solution.*

From now on, look out for these special cases (you won't see them often) and give the appropriate answer.

ACTIVITY 3

To confirm that solutions are correct

[LO 2.4, 2.6]

- For many problems in mathematics it is very difficult to know whether our answers are correct, but when we solve equations it is very easy. We simply check our answer! This has to be done very carefully, in a specific form.

This is how: Let's go back to question 8 above.

(a) $5(x + 1) = 20$ gives a solution: $x = 3$

We start with the original equation.

Check the left hand side (LHS) and right hand side (RHS) *separately*.

Substitute the solution for x and simplify:

$$\text{LHS} = 5(x + 1) = 5[(\mathbf{3}) + 1] = 5(3 + 1) = 5(4) = 20$$

As usual, using brackets when substituting is very helpful.

$$\text{RHS} = 20$$

Because the RHS and LHS are equal, we know the solution is correct.

(b) $8 + 4(x - 1) = 0$ Let's pretend the solution obtained was $x = 2$. Test it:

$$\text{LHS} = 8 + 4(x - 1) = 8 + 4[(\mathbf{2}) - 1] = 8 + 4(2 - 1) = 8 + 4(1) = 8 + 4 = 12$$

$$\text{RHS} = 0$$

Because the LHS \neq RHS we know that 2 is not a solution to this equation.

The real solution is, of course, $x = -1$. Let's check it:

$$\text{LHS} = 8 + 4(x - 1) = 8 + 4[(-\mathbf{1}) - 1] = 8 + 4(-1 - 1) = 8 + 4(-2) = 8 - 8 = 0$$

Now the LHS = RHS, and we have confirmed that $x = -1$ is the correct solution.

(c) $x(x + 3) = x^2 + 6$ solution: $x = 2$

$$\text{LHS} = x(x + 3) = (\mathbf{2})(\mathbf{2} + 3) = 2(2 + 3) = 2(5) = 10$$

$$\text{RHS} = x^2 + 6 = (\mathbf{2})^2 + 6 = 4 + 6 = 10$$

LHS = RHS, therefore $x = 2$ is the correct solution.

(d) $\frac{1}{2}(4x + 6) = 1$ solution: $x = -1$

$$\text{LHS} = \frac{1}{2}(4x + 6) = \frac{1}{2}(4(-\mathbf{1}) + 6) = \frac{1}{2}(-4 + 6) = \frac{1}{2}(2) = 1$$

$$\text{RHS} = 1$$

LHS = RHS, therefore $x = -1$ is the correct solution.

Now go back to problems 5, 6 and 7 and check your answers in the same way.

If we go back to the special cases in question 9, we can check them too:

(a) $2(x + 1) = x + 2$ gives a solution: $x = 0$

$$\text{LHS} = 2(x + 1) = 2((\mathbf{0}) + 1) = 2(0 + 1) = 2(1) = 2$$

$$\text{RHS} = x + 2 = (\mathbf{0}) + 2 = 2$$

LHS = RHS, therefore $x = 0$ is the correct solution.

(b) $2(x + 3) = 2x + 6$ gave a solution of any number! Let's use 5; you can try another.

$$\text{LHS} = 2(x + 3) = 2((\mathbf{5}) + 3) = 2(5 + 3) = 2(8) = 16$$

$$\text{RHS} = 2x + 6 = 2(\mathbf{5}) + 6 = 10 + 6 = 16$$

LHS = RHS as $x = 5$. In fact, LHS will equal RHS for any value.

(c) $3 - 2x = -2(1 + x)$ No number will give a solution; let's try 12. You can try some more.

$$\text{LHS} = 3 - 2x = 3 - 2(\mathbf{12}) = 3 - 24 = -21$$

$$\text{RHS} = -2(1 + x) = -2(1 + (\mathbf{12})) = -2(1 + 12) = -2(13) = -26$$

LHS \neq RHS and they won't be equal for any number.

ACTIVITY 4

To tell expressions and equations apart

[LO 2.1, 2.6]

- **Expressions** are combinations of letters (a , b , x , y , etc), operations ($+$, $-$, \times , [U+FOB8]) and numbers (1 , -5 , π , $\frac{1}{2}$, etc.) as well as brackets and other signs. An expression does not include equal signs.
- An expression is a little like a word or a phrase – it does not have a verb.
- Here are some examples: x , x^3 , $5\frac{1}{2}$, $2\pi r$, $5(ab - bc)$, $5a^3 - 3a^2 + a - 3$, $\sqrt{2(a + b)}$, $\frac{5a-4}{2a^2}$, etc.
- An expression can only be *manipulated*, usually to simplify it. It cannot be solved; it has no solution. The only way to check your work is do the steps backwards, to see whether you come back to the first step.
- An **equation** is two *expressions* with an equal sign in between!
- It is like a sentence with a verb; it makes a statement. For example $2x - 3 = 45$ says that double a certain number, with three subtracted, is equal to 45. Our job is to find that number.
- Equations must be solved; they have solutions that can be checked.

- We do a lot of simplifying while we solve equations, but we do more – we are allowed to do more. Remember we could subtract or add terms, as long as we do it to both sides! We could multiply or divide by factors, as long as we do it to both sides. Because an expression does not have two sides we can't do these things to expressions. Be very careful not to mix them up, and practise until you know instinctively what to do.

ACTIVITY 5

To solve two equations simultaneously

[LO 2.4, 2.9]

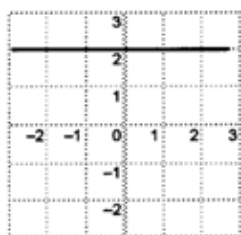

Diagram 1

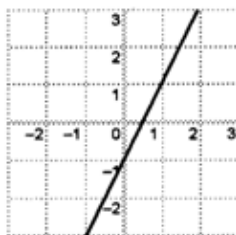

Diagram 2

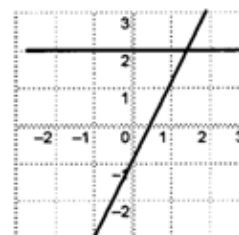

Diagram 3



Figure 3.27

1. The line in figure 1 has defining equation $y = 2$.

Question: Does the point $(1 ; 1)$ lie on the line?

Answer: We can obtain the answer *graphically* (by looking at the graph). So we can see that the point does not lie on the line, making the answer no.

We can obtain the answer *algebraically*, as follows: Substitute the point $(1 ; 1)$ for $(x;y)$ in the equation. Do the LHS and RHS separately as before.

LHS: $y = (1) = 2$ RHS: 2 LHS \neq RHS – the point $(1 ; 1)$ does not lie on $y = 2$.

Question: Does the point $(-2 ; 2)$ lie on the line?

Graphically: Yes.

Algebraically: LHS: $y = (2) = 2$ RHS: 2 LHS = RHS; yes it does.

Question: Does the point $(1\frac{1}{2} ; 2)$ lie on the line? Find the answer both graphically and algebraically.

2. The line in figure 2 is defined by the equation $y = 2x - 1$.

Questions: Does the point $(0 ; 0)$ lie on the line?

Does the point $(1 ; 1)$ lie on $y = 2x - 1$?

Does the point $(1\frac{1}{2} ; 2)$ lie on the line?

3. In figure 3 the same two lines are drawn together on the same set of axes.

Answer graphically: Which point lies on both lines? The answers to questions 1 and 2 above will be helpful.

It is easy to see from the graph that the only point that lies on both lines is $(1\frac{1}{2} ; 2)$.

- This can also be determined algebraically:

From the line $y = 2$ we can see that y has the value 2. If we substitute this value into the equation $y = 2x - 1$.

We can solve the equation to get a value for x . So:

Substitute: $(2) = 2x - 1$ and solve for x :

$2 = 2x - 1$ now move the x -terms to the left

$-2x + 2 = -1$ now move the constant terms to the right

$-2x = -2 - 1$ simplify

$-2x = -3$ divide both sides by -2

$x = -3$ [U+FOB8] -2 simplify

$x = 1\frac{1}{2}$

This shows that the point where the lines cross is $(x ; y) = (1\frac{1}{2} ; 2)$.

- In this method we have solved the two equations simultaneously, to find the values of the variables, which make both equations true. If an equation has only one variable, we need only one equation to find that value of the variable that makes the equation true. If we have two variables, we need two equations to solve for both variables.

Problems:

1 Solve algebraically for a and b : $2a - 3b = 0$ and $a = 6$.

2 Where do the lines $y = -x + 5$ and $y = -1$ cross? Find the answer algebraically.

3 Does the point $(3 ; 4)$ lie on both line $y = 4$ and line $y = -x + 1$? Do algebraically.

4 Do the lines $y = -2$ and $y = 2$ intersect? Find the answer algebraically.

ACTIVITY 6

To solve simple exponential equations

[LO 2.4, 2.8]

Problems and some answers

1 I am thinking of a number that gives 100 when squared. What is the number?

The number could be 10, because $10^2 = 100$. But is -10 not also a correct answer?

Yes, this problem has two valid answers!

Making an equation from this statement means starting by letting x be the number.

[U+F05C] $x^2 = 100$

[U+F05C] $x^2 = 10^2$ of $x^2 = (-10)^2$ The brackets are essential – can you see that?

[U+F05C] $x = 10$ of $x = -10$ Both answers are valid.

2 I am thinking of a negative number that gives 25 when squared. What is it?

Let the number be y

[U+F05C] $y^2 = 25$

[U+F05C] $y^2 = (5)^2$ of $y^2 = (-5)^2$

[U+F05C] $y = 5$ of $y = -5$ are the two solutions given by the equation.

According to the problem statement, though, only $y = -5$ is a valid answer.

3 There is a number that gives 27 when it is cubed. Find the number.

Let the number be x

[U+F05C] $x^3 = 27$ [U+F05C] $x^3 = 3^3$ [U+F05C] $x = 3$.

Why can't x be -3 ?

4 If I cube a certain number I get -8 . What is the number?

5 Solve for x , and check your answers by the LHS/RHS method:

a) $x^2 = 64$ b) $x^2 = 36$ c) $x^2 = -100$ d) $x^2 - 49 = 0$

e) $x^2 = 12,25$ f) $3x^2 = 12$ g) $2x^2 - 10,58 = 0$

6 Solve for a and check your answers:

a) $a^3 = 64$ b) $a^3 + 1 = 0$ c) $2a^2 = 16$ d) $a^4 = 81$

Score yourself on the last 12 problems:

3.5.7 Assessment

LO 2
Patterns, Functions and AlgebraThe learner will be able to recognise, describe and represent patterns and relationships, as well as to solve problems using algebraic language and skills.
We know this when the learner:
2.1 investigates, in different ways, a variety of numeric and geometric patterns and relationships by representing and generalising them, and by explaining and justifying the rules that generate them (including patterns found in nature and cultural forms and patterns of the learner's own creation;
2.2 represents and uses relationships between variables in order to determine input and/or output values in a variety of ways using:
2.2.1 verbal descriptions;
2.2.2 flow diagrams;
2.2.3 tables;
2.2.4 formulae and equations;
2.3 constructs mathematical models that represent, describe and provide solutions to problem situations, showing responsibility toward the environment and health of others (including problems within human rights, social, economic, cultural and environmental contexts);
2.4 solves equations by inspection, trial-and-improvement or algebraic processes (additive and multiplicative inverses, and factorisation), checking the solution by substitution;
2.5 draws graphs on the Cartesian plane for given equations (in two variables), or determines equations or formulae from given graphs using tables where necessary;
2.6 determines, analyses and interprets the equivalence of different descriptions of the same relationship or rule presented:
2.6.1 verbally;
2.6.2 in flow diagrams;
2.6.3 in tables;
2.6.4 by equations or expressions;
2.6.5 by graphs on the Cartesian plane in order to select the most useful representation for a given situation;
2.8 uses the laws of exponents to simplify expressions and solve equations;
2.9 uses factorisation to simplify algebraic expressions and solve equations.

Table 3.23

3.5.8

3.6 Collecting information to answer general questions⁶

3.6.1 MATHEMATICS

3.6.2 Grade 9

3.6.3 NUMBER PATTERNS, GRAPHS, EQUATIONS,

3.6.4 STATISTICS AND PROBABILITY

3.6.5 Module 17

3.6.6 COLLECT INFORMATION TO ANSWER GENERAL QUESTIONS

ACTIVITY 1

To learn that we must collect information to be able to answer general questions
[LO 5.1]

It is useful to have information about people. For instance, if the government has to decide how many new schools to build and where to build them, then they need to know how many children there are in every region of the country, especially children who are not yet attending schools. The same applies for decisions about building new clinics and hospitals, and so on.

People who want to market a new product will want to know how many people would be interested in buying their product. For this they need to ask questions and obtain statistics.

The professionals who work in this field are called statisticians. It is their job to see that the information that is gathered is the best possible (we will learn more about this later). They then study and manipulate the data so that sensible decisions can be based on them.

The basis of statistics is figures, which are obtained from asking questions. We are going to do some quick research.

The government organises a *census* from time to time to obtain information about the population. At that time many extra people are employed to gather the details of every person in the country. It usually takes a few years to organise all the information and to publish it. The information is then made public so that it can be used by people who need to plan on the basis of accurate figures.

Important note: Please keep any information that you work on in this section – we will use it again later. As you learn how to work with statistics, we will get more and more information from your data.

1. Think about your whole family – parents, grandparents, siblings (brothers and sisters), aunts, uncles – everybody. Count how many extended family members you have. How many of them have cell phones? How many of them have had cell phones stolen? How many of them have lost their cell phones? Fill the information in on the following table, and in the last row fill in the totals for the whole class

	Number of people	Owns a cell phone	Has had cell phone stolen	Has lost cell phone
Learner				
Class				

Table 3.24

2 Work in groups of three or four. Each must write down two sports that they would particularly like to take part in. These sports need not be school sports. For each of the sports, they must say whether they already play it, whether they are members of a team or whether they can't play it because they don't have

⁶This content is available online at <<http://cnx.org/content/m31279/1.1/>>.

access to facilities and equipment or don't have access to a coach. Again, fill the information for your group in on the table.

Name										
Sports 1:					2:					
	Play it	In a team	No coach	No equipment	No facilities	Play it	In a team	No coach	No equipment	No facilities
	<input type="checkbox"/>	<input type="checkbox"/>	<input type="checkbox"/>	<input type="checkbox"/>	<input type="checkbox"/>	<input type="checkbox"/>	<input type="checkbox"/>	<input type="checkbox"/>	<input type="checkbox"/>	<input type="checkbox"/>

Figure 3.28

3 Here are some more of the type of questions that statisticians might work on:

3.1 How representative are the learners in a particular school of the population of the area where the school is?

3.2 What are the attitudes of the people living in a certain region to the proclamation of a part of the area as a wildlife preservation area?

3.3 How many people in a particular province are HIV positive?

3.4 How does the prison population of one province compare with that of another province?

3.5 When one looks at the number of women in our parliament, how does that compare with the situation in other democratic countries?

3.6 What is the distribution of wealth in the world – in other words, what percentage of the world's population owns, say, half of the world's wealth?

ACTIVITY 2

To learn about using various methods for gathering data

[LO 2.2, 5.2]

In the research about the cell phones and sport, it was easy to get information. But sometimes one has to work a little harder.

1 When one has to *count* something (for example, the number of left-handers in the school), the easiest way is to use a tally table

- Below is a tally table for filling in information about the ages and sex (male or female) of you and your siblings (brothers and sisters). For each sister, you make a little line (a tally) in the "sisters" row under the appropriate age. For each brother you do the same in the "brothers" row. Don't forget yourself! Every learner in the class must do the same. Every time you have to add a fifth tally, you put it across the four others – this makes it easier to add all the tallies at the end to get the totals for each age. The first tally table shows an imaginary example – you will use the second one for your class.

Ages	<1	1	2	3	4	5	6	7	8	9	10	11	12	13	>13
Sisters	### ///	###	### ###	### ////	///	###	### ////	////	###		###	###	### ////	###	### ###
Brothers	###	///	### ////	###		////	### ////	###	###	### ///	###	###	////	###	###
Total sisters	8	6	10	9	3	7	9	4	6	2	6	5	9	7	10
Total brothers	6	3	9	7	2	4	9	5	6	8	6	7	4	7	6

Figure 3.29

Ages	<1	1	2	3	4	5	6	7	8	9	10	11	12	13	14	15	16	17	18	19	20	21	22	23	24	>24	
Sisters																											
Brothers																											
Total sisters																											
Total brothers																											

Table 3.25

- The numbers in the bottom two rows give the *frequency* of the occurrence of the different ages. A frequency table shows the *frequency distribution* of the characteristic being studied.
- You can see that the tables in the cell phone and sport examples are also frequency tables.

2 *Questionnaires* are used when the information to be gathered is more complicated than can be entered on a tally table

- Someone might stop you in a shopping centre and *interview* you about your toothpaste and flossing habits.
- The questionnaire form might have questions like:
 - Do you use toothpaste never, once, twice or more than two times a day?

- Do you buy a new toothbrush every week, every month or every year?
 - Do you floss your teeth regularly or only when you think you have food stuck in your teeth?
 - Do you prefer flavoured toothpaste?
 - Do you like coloured toothpaste?
 - Do you go the dentist regularly or only when necessary?
 - How many fillings have you had?
 - Have you had any teeth extracted?
- Form small groups and briefly discuss some of the possible reasons why someone might want this information.
- Many questionnaires are printed in newspapers and magazines. Sometimes they are just for fun, and you can analyse them and read the results right away. But some can be serious, and you might be asked to post them back. Often, to encourage people to participate, a prize or reward might be offered! Many people hate filling in questionnaires, and they have to be persuaded – but for others it is great fun and they don't mind being helpful.

3 Another way of getting information is to do an experiment.

- This is often used by medical researchers. For example, they may have developed a new medical treatment and they want to find out whether it is better than the old treatment, the same, or worse. If they know that it won't harm people (sometimes they are not sure about this!), they might get permission from the appropriate government department to allow doctors to prescribe the new medicine. The doctors will then fill in questionnaires about how their patients responded, and give the information to the researchers to study.

4 You don't always have to ask people for information. Many questions can be answered just by doing some research on your own. For example:

4.1 Are the storybooks in the English section of the library longer than the storybooks in the other languages? To answer this question, you have to look at the last page number in each book and make some calculations

4.2 If I want to write a story for a magazine, how many words must the story be? Look at several issues of the magazine you want to write for and count the words in all the short stories. If you can calculate the average length (you will still learn about averages) of their stories, then you know how long yours must be.

5 How popular are your favourite actors? Type their names into an Internet search engine and count how many *hits* (number of articles with the name) the search engine finds.

6 You can do an experiment in your class. Read the description below and plan exactly how things will be done, who will do what job and how you will record the results. When you are sure of all the details, you can proceed with the experiment.

EXPERIMENT

- You will need two kinds of fizzy cool drink or fruit juice – choose two that some people say taste exactly the same; it will be very good if they also look the same. Blindfold the person who will be tested (the taster). Everyone (except the experimenter and the assistant) should take a turn to be the taster.
- Someone (the experimenter) pours out a little of each drink where it can't be seen. Use differently coloured cups. Only the experimenter will know which drink is in which cup, and this is filled in on a list that is kept secret. When the taster decides which is which, the experimenter's assistant makes a note of the cup colour.
- The experimenter looks at the answers, and depending on the cup colour decides whether the taster was right or wrong. After everyone has had a turn to be a taster, it may be possible to decide whether the drinks can really be told apart!

- If there is time the class may think of another question that can be answered by an experiment. The experiment can be designed and carried out to see if there is an answer. ACTIVITY 3

To investigate the validity of the information-gathering process

[LO 5.2]

- There is another important part of getting information that must be discussed before we can continue. Do the following exercise in a small group of four or five learners.
- Say that you would like to know how many people in South Africa watch the news on TV.
 - Well, you can go to every single person in the country and ask them, tally the answers and add them up and you'll have a very accurate answer – if nobody tells a lie, of course.
 - This would be a very long and expensive job. During the *census*, the government tries to ask a few important questions of every single person. This costs a lot of money, and they don't manage to be perfectly accurate.
 - Perhaps we don't have to ask everybody – we can ask a few and get an answer in that way. If there are 45 million people in the country, we can ask 45 of them whether they watch the news and then, if 30 say they do, maybe this means 30 million South Africans also do.
- Statisticians call this process *sampling*. If the total *population* we are interested in is too big, we can look at a smaller number (the *sample*) and multiply from that to get the real answer.
- Imagine the learners in your class have to gather the data to answer the question. You decide to take turns to spend an hour each weekday standing at a filling station to ask motorists whether they watch the TV news. This is good because you are under a roof, and the motorists have to stop and wait a few minutes anyway, so most of them might not mind giving you an answer if you ask nicely with a smile?
- Imagine that this works wonderfully. For two weeks you have been at the filling stations in the area and you have a lot of tallies. You very cleverly counted how many people you asked, how many wouldn't answer, and how many said NO and how many said YES.
- Now transform these figures into an accurate estimate of how many of the total population of the country watch the TV news.
 - Discuss in your group exactly how you would do this survey.
 - Also discuss how accurate you can expect the answer to be – in other words, if you could get everybody in the country to answer, would that “real” answer be the same as the one you calculated from your tallies? Write a short and clear summary of the conclusions your group came to after the discussions.

3.6.7 Assessment

LO 2
<i>continued on next page</i>

Patterns, Functions and Algebra	The learner will be able to recognise, describe and represent patterns and relationships, as well as to solve problems using algebraic language and skills.
	We know this when the learner:
	2.1 investigates, in different ways, a variety of numeric and geometric patterns and relationships by representing and generalising them, and by explaining and justifying the rules that generate them (including patterns found in nature and cultural forms and patterns of the learner's own creation);
	2.2 represents and uses relationships between variables in order to determine input and/or output values in a variety of ways using:
	2.2.1 verbal descriptions;
	2.2.2 flow diagrams;
	2.2.3 tables;
	2.2.4 formulae and equations.
	LO 5
Data Handling	The learner will be able to collect, summarise, display and critically analyse data in order to draw conclusions and make predictions and to interpret and determine chance variation.
	We know this when the learner:
	5.1 poses questions relating to human rights, social, economic, environmental and political issues in South Africa;
	5.2 selects, justifies and uses appropriate methods for collecting data (alone and/or as a member of a group or team) which include questionnaires and interviews, experiments, and sources such as books, magazines and the Internet in order to answer questions and thereby draw conclusions and make predictions about the environment.

Table 3.26

3.6.8**3.6.9****3.6.10****3.6.11****3.6.12 Memorandum****3.7 Analyse data for meaningful patterns and measures⁷****3.7.1 MATHEMATICS****3.7.2 Grade 9****3.7.3 NUMBER PATTERNS, GRAPHS, EQUATIONS,****3.7.4 STATISTICS AND PROBABILITY****3.7.5 Module 18****3.7.6 ANALYSE DATA FOR MEANINGFUL PATTERNS AND MEASURES****ACTIVITY 1**

To analyse data for meaningful patterns and measures

[LO 5.3]

- Now we need to gather information about the heights of the learners in your class. Fasten a measuring tape like the one dressmakers use to the side of the door, so that it is perfectly vertical. If you can't find a tape, you can use some other way – maybe making small marks very accurately every centimetre on the wall, using rulers.
- Each learner takes off her shoes and stands with her heels and back tightly against the wall. Someone who is tall enough holds a ruler or piece of cardboard flat on her head to see exactly how tall she is. It is a good idea to take the measurement in centimetres and not in millimetres. Write the answer on her hand (or on a piece of paper).
- We do our first calculation in an interesting way: When everyone has been measured, all the pupils stand in line **in the order of their heights**.
- From this line of pupils we get the **first** measurement of the average of the class. Write down the height of the pupil who is exactly in the centre of the line (equally far from the beginning as from the end). This number is called the *median*. There are as many learners shorter than she is, as there are taller than she is. Note: if there are an even number of learners in the class, then of course there will not be a middle person. In that case we take the two middle persons, add their heights and divide the answer by two.
- Write down the median height for your class. If you are in a class with both boys and girls, work out the medians for the boys and girls separately

⁷This content is available online at <<http://cnx.org/content/m31280/1.1/>>.

- Next make a frequency table for the heights and use tallies to count how many of each height you have in the class.

Go back to the table of ages of siblings and find the median age of the boys and girls separately. Your table is likely to be very big, but here is a smaller example of what you should do:

cm	155	156	157	158	159	160	161	162	163	164	165	166	167	168
Tallies										 				
Total	1	2	0	2	4	3	5	4	2	6	4	3	0	2

Figure 3.30

- See whether you agree that the median height for this group is 162 cm.
- If you study the numbers in the last row (they give the frequencies of the different heights) you will see that 164 cm is the height that occurs most often as there are six learners who are 164 cm tall. This number is called the *mode*. We can think of it as the most popular height.
- The next calculation is the one that gives us the value that we usually call the *average*. Its proper name is the *arithmetic mean*, or just *mean*. You may already know how to calculate it: you add all the values and then divide the answer by the number of values. For the table above you divide 6156 by 38 to get a mean height for the class of 162 cm.
- We can make a table of these values: Use the table of ages of siblings again and calculate the mode and mean for boys and girls separately and then fill these values in on a table like the one alongside

Median	162 cm
Mode	164 cm
Mean	162 cm

Table 3.27

- These values (mode, median and mean) are together called *measures of central tendency*. They are all different kinds of **averages**. That is why, when we use the word **average** to refer to the arithmetic mean, we are not being perfectly accurate. From now on, you can use the word *mean* where you would have said *average* before.
- Use the heights for your class and complete the calculations.

- Now carefully study the frequency table for the heights of another class of 38 learners:

cm	158	159	160	161	162	163	164	165	166
Total	1	4	6	6	5	4	7	4	1

Table 3.28

- Calculate the three measures of central tendency for this class as well.
- Compare the heights of the learners in the two classes and write a short essay about the similarities and differences you found.

ACTIVITY 2

To extract more information from data
[LO 5.3]

Median	162 cm
Mode	164 cm
Mean	162 cm

Table 3.29

As you see from the heights of the learners in the previous example, the two classes have different heights but the three averages are exactly the same.

We can tell a little more about the data by using measures of dispersion. These tell us more about how the values are distributed.

- The first is the *range*, calculated by taking the highest value and subtracting the lowest value from it. Do this for both classes. As you can clearly see, the first class has a range of 13 cm and the second class has a range of 8 cm.
- The second measure of dispersion is the *mean deviation*. This is calculated firstly determining how far each value deviates (or differs) from the *mean* (which we have already calculated). Then we calculate the mean of these deviations to give the mean deviation.
- We make another table from the data for the second class, which has all the heights and the deviation of each value from the mean:

158	159	159	159	159	160	160	160	160	160	160	161	161	161	161	161	161	162	162
4	3	3	3	3	2	2	2	2	2	2	1	1	1	1	1	1	0	0

Table 3.30

162	162	162	163	163	163	163	164	164	164	164	164	164	164	165	165	165	165	166
0	0	0	1	1	1	1	2	2	2	2	2	2	2	3	3	3	3	4

Table 3.31

- The total of all these deviations is 68. Dividing by 38 we get 1,79 when rounded to two places.
- Do the same calculation for the other class.
- Now you can calculate the two measures of dispersion for your own class.

Measures of dispersion are very useful when you want to compare two sets of data, like the heights of learners in two different classes. There are other measures of dispersion, but they are not taught in this course.

- At this stage you are very good at tabulating data, calculating values to describe the data as well as making some inferences about the data
-

ACTIVITY 3

To use new skills to investigate and compare some test marks
[LO 5.3]

- Compare the test marks for the same test obtained by two groups of learners, shown in the table below. You have to use all the skills you have learnt so far in this learning unit, to see whether you can say whether one group did better than the other. This is not a simple question, and you are not easily going to see an answer without some careful work and concentrated thinking.

Group A	82	78	57	91	29	80	85	49	82	67	99	68	83	12	87	86	38	81	58	79
Group B	72	82	74	84	81	84	76	12	2	71	70	93	13	90	80	73	91	70	99	88

Table 3.32

ACTIVITY 4

To represent data in ways that make it easier to understand their meaning
[LO 2.2, 2.6, 5.4]

In the work on graphs you saw that a graph gives a much better picture of the meaning of data.

- Now you will be learning more about different kinds of *graphical representation* of data. This means mainly that you make the meaning of data visible without always having to do intricate calculations.

1 Line graphs

- You have already been shown that when you have plotted a number of points (for instance from a table) on graph paper, the points may lie in a straight line, which you can draw.
- But it is not always correct to join them with a line. Think back to the stepped graphs.
- Sometimes the points will not lie in a straight line, but if they are joined they form, zig-zag line. This is often called a broken-line graph. But – is it always sensible to join the points?
- Below is a part of the frequency distribution of ages of siblings we had before.

Ages	<1	1	2	3	4	5	6	7	8	9	10	11	12	13
Total sisters	8	6	10	9	3	7	9	4	6	2	6	5	9	7
Total brothers	6	3	9	7	2	4	9	5	6	8	6	7	4	7
Total	14	9	19	16	5	11	18	9	12	10	12	12	13	14

Table 3.33

2 Bar graphs

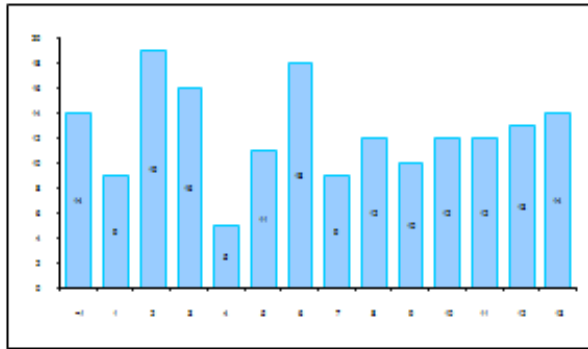

Figure 3.31

The next bar graph shows the girls and boys separately, but because the bars are stacked the top of the bar shows the total of boys and girls as well.

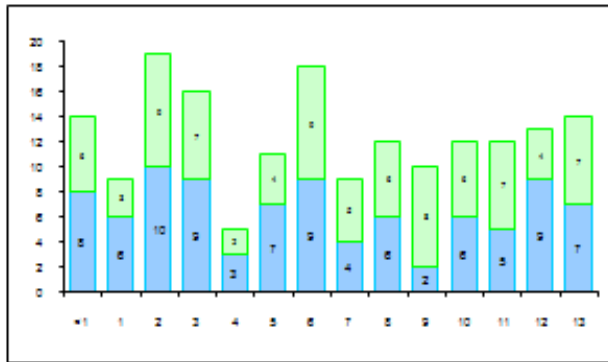

Figure 3.32

The same information can be drawn as bar graphs in a number of different ways; here is another one, with the bars next to each other, for you to study. Write a few sentences on the different bar graphs and how (in your own opinion) they represent the information most usefully.

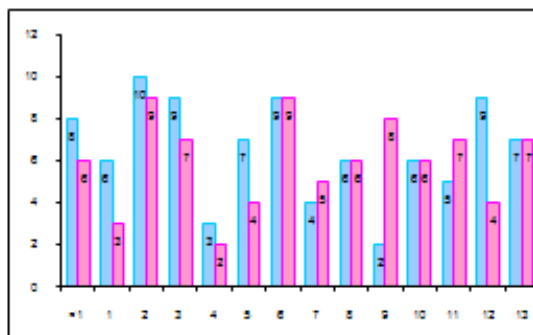

Figure 3.33

3 Histograms

- The publishers of a certain youth magazine wanted to find out how old their readers were. They asked the ages of everybody who bought the magazine at a stationery kiosk in a shopping mall. The categories shoppers could choose from, were:
 - Under 5
 - From 5 to 8, but not yet 8
 - 8 years old
 - 9 years old
 - More than 9 but less than 10 years and 6 months
 - More than $10\frac{1}{2}$ years, but not yet 11
 - More than 11 years, but not yet $11\frac{1}{2}$
 - More than $11\frac{1}{2}$ years, but not yet 12
 - More than 12 years, but not yet $12\frac{1}{2}$
 - More than $12\frac{1}{2}$ years, but not yet 13
 - More than 13 years, but not yet $13\frac{1}{2}$
 - More than $13\frac{1}{2}$ years, but not yet 14
 - More than 14 years, but not yet 15
 - Between 15 and 16
 - Between 16 and 18
 - Between 18 and 20
 - Under 25
 - 25 to 60
- This is the first part of the table completed from their data:

Age	0	5	8	9	10	10,5	11	11,5	12	12,5	13	13,5	14	15	16	18	20
	<5	<8	<9	<10	<10,5	<11	<11,5	<12	<12,5	<13	<13,5	<14	<15	<16	<18	<20	<25
Frequency	2	2	3	1	2	2	4	2	3	5	2	1	2	2	0	1	

Table 3.34

- Below is the *histogram* drawn from the data in the table. A histogram is very similar to a bar graph, but the bars are not separated, and the width of the bars depends on the size of the *intervals*.
- In the table we can see that the age intervals are not all the same; the first interval is five years, the next three years, etc. Fill in the missing horizontal axis labels yourself.

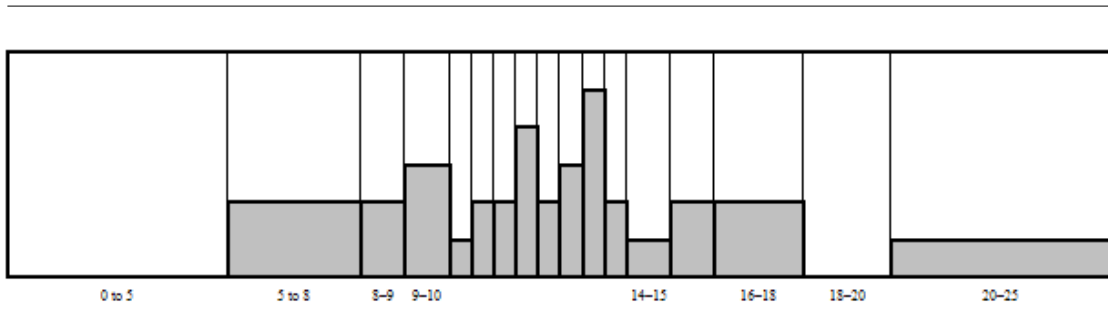

Figure 3.34

- In the learner height data, all the intervals were 1 cm, which makes a bar graph a good and easy choice.
- It is easy to make a mistake and draw a bar graph when you should be making a histogram because the intervals vary – be sure to check the interval lengths every time.

4 Pie charts

- Pie charts have this name because they look like sliced pies!
- Study the following examples.
- The table shows the eating habits of learners attending a certain high school. They were asked to complete a small questionnaire, from which the data in the table was compiled.

Had no breakfast at home	Breakfasted at home	Brought breakfast to eat at school	Had lunch after going home	Brought lunch to school	Bought lunch from tuck shop	Brought extra snacks to school
82	357	141	54	406	120	227

Table 3.35

- There are 580 learners at the school. Can you confirm this from the figures in the table?
- A pie chart was made from the breakfast information, and another from the lunch figures. Decide which is which, then fill in the descriptions on the correct slice of each pie chart.

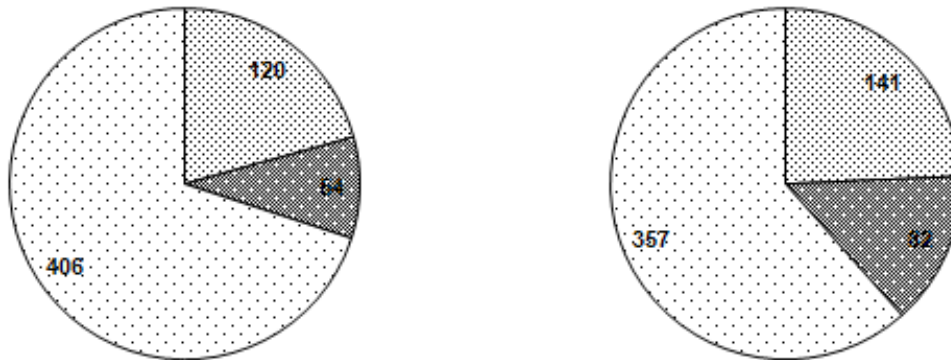

Figure 3.35

- As you can see, the slices are not all the same size. The sizes are proportional to the number of learners represented in each slice. The way to get them in the right proportions is to calculate the size of the angle at the tip of each slice. For example, $82 \div 580 \times 360 = 51^\circ$, rounded. This is the angle at the tip of the slice representing the proportion of learners who don't eat breakfast before coming to school. The formula is: $\text{angle size} = \frac{\text{value}}{\text{total number}} \times 360$. Do the calculations for all five the other slices, and confirm by measurement that the slices are the right size!
- Of course, in the end the slices have to add up to 360° .

5 Scatter plots

- This graph consists only of the plotted points. It links two sets of information on one graph, making comparisons easy. Let's look at an example.
- The table shows the marks obtained in Science and Maths for a group of 22 learners.

Pupil	A	B	C	D	E	F	G	H	I	J	K	L	M	N	O	P	Q	R	S	T	U	V
Science	75	45	28	66	58	81	23	69	60	48	72	37	47	90	57	88	45	56	62	40	53	48
Maths	65	31	40	67	52	75	34	95	70	66	58	40	45	84	75	70	55	61	53	55	72	49

Table 3.36

- Here is the scatter plot

For each learner, the coordinates of the point are (Science mark ; Maths mark). Learner A is (75;65). Can you find the dot? Learner B is (45;31), etc. The squares on the paper are not shown, so that the dots can be seen more clearly.

If the dots lie in a pattern (as these do) roughly from bottom left-hand corner to top right-hand corner, then it means there is a connection between the marks a learner gets for the two subjects.

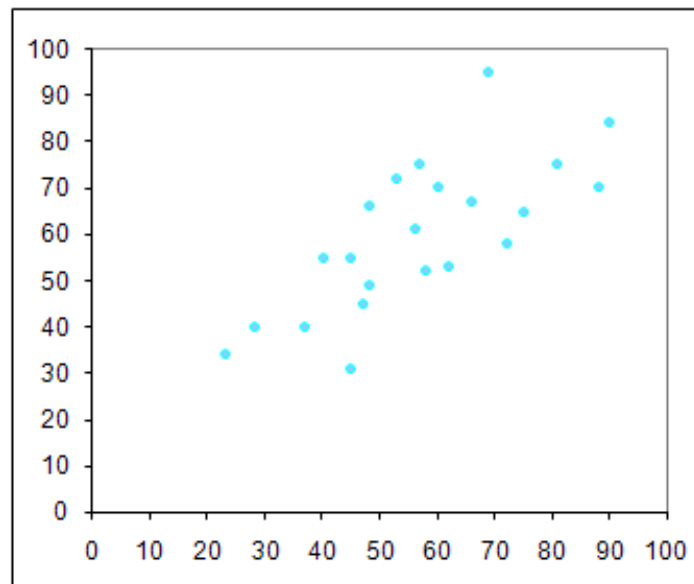

Figure 3.36

- Those learners, whose marks don't correlate, are clear from the graph. Find the two circled points. For example, the point (69;95) of learner H, is a little bit higher than the rest of the points. This tells us that the learner has a better Maths than Science mark, but learner B (45;31) does much better in Science than in Maths. If everybody got exactly the same mark for both Science and Maths, then their points would make a very clear pattern. What do you think that pattern would look like?

3.7.7 Assessment

LO 5
Data HandlingThe learner will be able to collect, summarise, display and critically analyse data in order to draw conclusions and make predictions and to interpret and determine chance variation.
We know this when the learner:
5.1 poses questions relating to human rights, social, economic, environmental and political issues in South Africa;
5.2 selects, justifies and uses appropriate methods for collecting data (alone and/or as a member of a group or team) which include questionnaires and interviews, experiments, and sources such as books, magazines and the Internet in order to answer questions and thereby draw conclusions and make predictions about the environment;
5.3 organises numerical data in different ways in order to summarise by determining:
5.3.1 measures of central tendency;
5.3.2 measures of dispersion;
5.4 draws a variety of graphs by hand/technology to display and interpret data including:
5.4.1 bar graphs and double bar graphs;

Table 3.37

3.8 Extract meaningful information from data⁸

MATHEMATICS

Grade 9

NUMBER PATTERNS, GRAPHS, EQUATIONS,
STATISTICS AND PROBABILITY

Module 19

EXTRACT MEANINGFUL INFORMATION FROM DATA

ACTIVITY 1

To be able to extract meaningful information from data

[LO 5.5]

As you know, graphs are to be seen everywhere: in advertisements, in textbooks, in magazine articles and in mathematics classes. In this section we will look at a wide selection of graphs and what we can say about the statistics they represent.

When we have only one set of values (for example the previous study of the breakfast and lunch habits of some learners), we can use a simple graph like a pie chart.

On the other hand, many graphs make a connection between two sets of values. We call this a relation.

Some examples from your previous work are: number of prison inmates in particular years; height above sea level at certain distances from a point; amount charged by a gardener for certain number of hours worked; y-values obtained from x-values substituted into a given formula; etc.

Usually this means that the graph will have a horizontal axis and a vertical axis. Just to remind you, here is the table of important words again:

⁸This content is available online at <<http://cnx.org/content/m31282/1.1/>>.

Equation:	x	y
Equation:	Independent variable	Dependent variable
Flow diagram:	Input value	Output value
Table:	First row	Second row
Coordinates:	1st coordinate	2nd coordinate
Graph:	x- axis	y- axis
Graph:	Horizontal axis	Vertical axis

Table 3.38

1 James and Gabriel are the same age – they are friends, both entering their first job at the start of January 2000. Each of them can easily take a bus to work. Each also has enough money from their holiday jobs to use as a deposit on a new car.

James wants a new car immediately, and now that he has a job, he arranges hire purchase financing for a car. He has enough for the deposit, and he can just about afford the monthly repayments. At the end of four years he replaces the car with another new one, a slightly nicer model. He again buys it on hire purchase, paying the deposit from the sale of his old car, and pays the higher instalments regularly. At the start of 2008, he does the same. Every four years he replaces his car.

Gabriel is willing to do something different. Instead of getting a new car immediately, he puts the money he would have used for the deposit into a savings account and saves up enough every month so that after four years he can buy a new car for cash. So in 2004 he chooses the same one his friend James does. Immediately he starts another savings account, making monthly payments big enough for a new car in four years' time like the one his friend buys then. In 2008, he sells his old car when he gets the new one, and puts the money in the bank to start his savings for the next car. So he also replaces his car every four years

In other words, from 2004 they drive exactly the same cars!

The information about their expenditure is given below as a bar graph as well as a table.

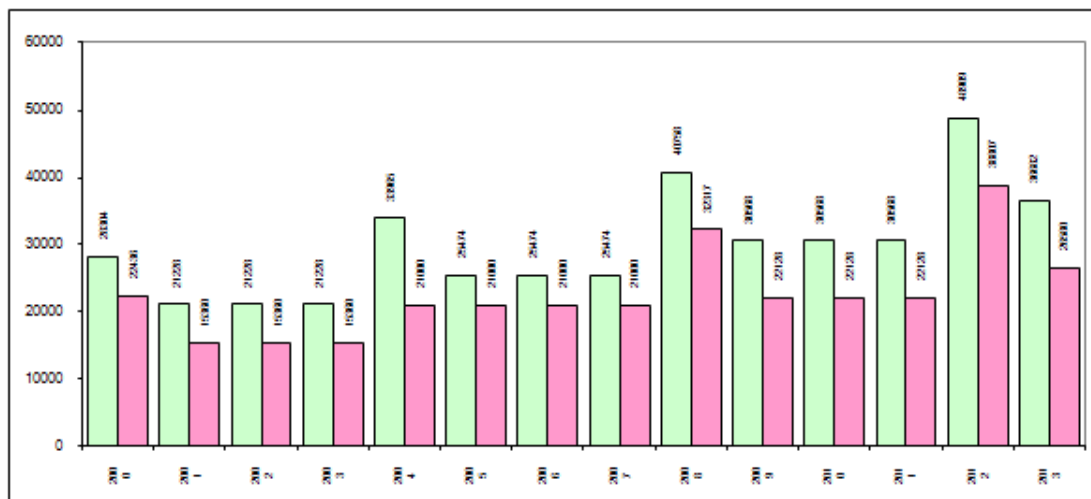

Figure 3.37

Year	2000	2001	2002	2003	2004	2005	2006	2007	2008	2009	2010	2011	2012	2013
James	28 304	21 228	21 228	21 228	33 965	25 474	25 474	25 474	40 758	30 568	30 568	30 568	48 909	36 682
Gabriel	22 436	15 360	15 360	15 360	21 000	21 000	21 000	21 000	32 317	22 128	22 128	22 128	38 807	26 580

Table 3.39

1.1 As you can see in the graph, the horizontal axis is marked in years. The bars show the amount of money paid in instalments by James, or saved up for a car by Gabriel. You will notice that the light bar is always higher than the dark bar for a specific year. Does the light bar show Gabriel's or James's situation?

1.2 Can one say whether Gabriel or James acted most wisely?

1.3 If both friends earn the same amount every month and get regular salary increases every year, who has the most left over every month to spend on other necessities, and fun?

1.4 Use the values in the table and calculate how much money each young man used in total in purchasing his cars over the whole period from 2000 to 2013.

1.5 When your father offers you his old car (which is still in sound working order) as a gift when you start work, will you accept and start saving for a new car of your own in a few years (like Gabriel) or will you decline his offer and buy a new car on hire purchase like James? Explain your answer.

1.6 Speak to a car salesman who sells new cars and ask him / her to explain exactly which conditions you have to comply with before you can enter into a hire purchase agreement. Ask about insurance, about who owns the car and about what happens if you can't continue with your repayments.

2 Straight-line graphs with positive gradients show a direct relationship between two variables. Some graphs show an inverse relationship between two variables. We will look at two situations with this kind of relationship.

2.1 Here is a situation that we will return to in the section on probability:

You have to guess a number between 1 and 6. A friend rolls one dice. You have one chance out of 6 of being right.

If your friend rolls two dice (plural of die) and you guess one number, you have six chances out of 21 of being right. If you guess two numbers, then there is only one chance out of 21 of getting both numbers right.

With three dice, guessing one number gives you a chance of 21 out of 56; two numbers gives 6 out of 56 and guessing all three numbers gives a chance of one out of 56.

Here is the scatter plot for the three-dice game, and one for a four-dice game.

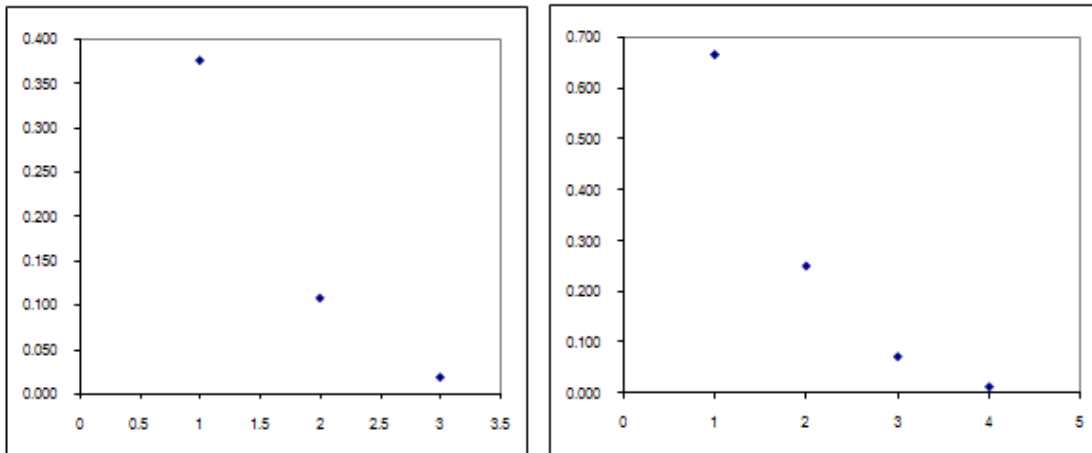

Figure 3.38

If you can imagine a curved line in each graph going through the points (it isn't sensible to join the points – why?), you will notice the lines have the same general shape. This shape of graph illustrates an inverse relationship between two variables.

2.2 Here is another practical example of this shape of graph:

Sindiswa and Alan are in charge of arranging a dance to raise money in support of the AIDS organisation in their neighbourhood. They can get a DJ who will do it for free, but they have to pay to hire a hall. There are four halls to choose from: A, costing R1 000 and accommodating 200; B, costing R1 400, accommodating 350; C, costing R1 800, accommodating 600 and D, costing R2 100 and accommodating 500.

They have drawn this graph showing how the four halls differ as far as costs go. Depending on how many people attend the dance (shown on the horizontal axis), the cost per person to cover the cost of the hall, is shown on the vertical axis. They would like to donate at least R4 000 to the charity, but it would be nice if they could make it R5 000.

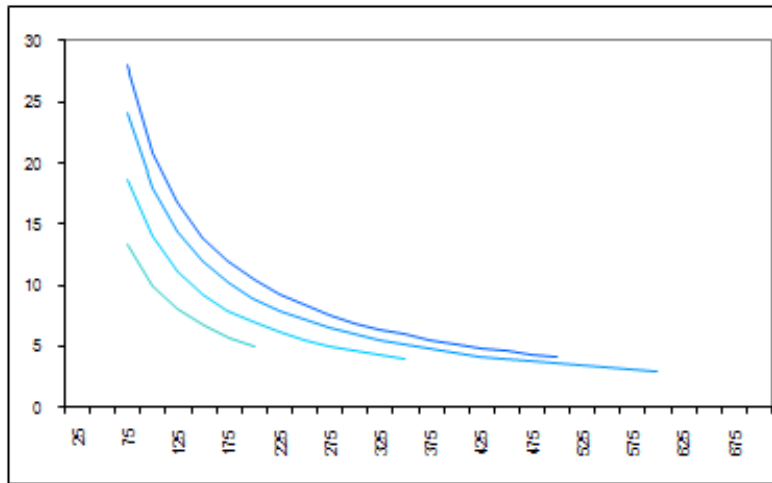

Figure 3.39

a) Can you say which line applies to which hall? If you use the number of people the hall can accommodate as a clue, it will be easy!

b) Now, use the information supplied to you as well as the graphs and discuss which hall will be the best one for Alan and Sindiswa to choose. Not everybody will get to the same answer, but you must give reasons for your choice.

3 Maybe you recognise this table of test marks of two classes from a previous exercise:

Group A	82	78	57	91	29	80	85	49	82	67	99	68	83	12	87	86	38	81	58	79
Group B	82	82	74	84	81	84	76	12	2	71	70	93	13	90	80	73	91	70	99	88

Table 3.40

This can be put on a stem-and-leaf graph, with Group A on the left, and Group B on the right. We separate the tens digits from the units digits, and put the tens digits in the middle, in order. The units then go next to the appropriate tens digit (on the left or the right depending on the group).

Study the graph together with the table to make sure you know how it works.

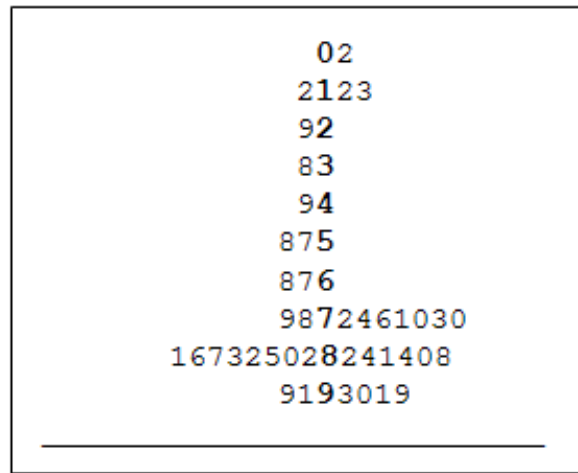

Figure 3.40

You were given this exercise earlier on to practise your skills in working out averages and finding out more about the differences between the two classes. The stem-and-leaf graph shows a few things we can't see easily from the table and we can't find out from the calculations. For example, class A has learners in every symbol class, but Class B has three learners with very poor marks and the rest with very good marks.

On the right is the same information drawn as two sideways bar graphs, one to the right and one to the left.

This is a very common and handy way to show data about two groups you are comparing. Ask your geography teacher about demographic graphs (also called demographic pyramids) in this form. We often find the ages of the population of a country shown with women on one side and men on the other. See if you can find one of these graphs.

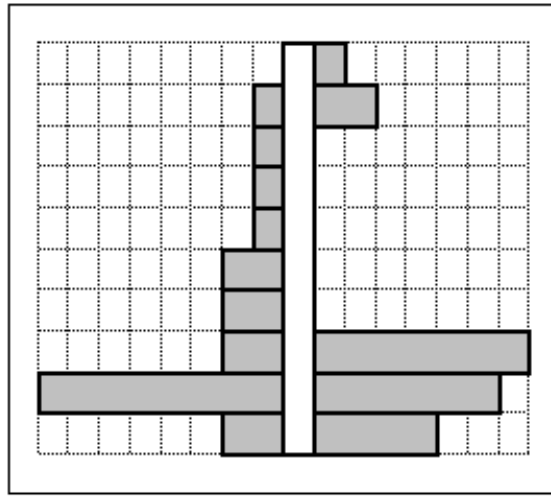

Figure 3.41

ACTIVITY 2

To avoid being fooled by poorly gathered or badly presented statistics

[LO 5.5]

It is easy to draw wrong conclusions from statistics, or to be presented with a graph that has been designed to make you believe something which is not so. Statisticians do a valuable job – we need information, and we need reliable information. Statisticians encounter many problems in assembling and presenting information.

1 One of the first things that can go wrong is in the way we gather that information. Go back to the exercise about TV news viewing. If you ask your questions at filling stations, you are talking to people who own a car (or at least drive one). This means that people who don't drive have been ignored in your survey. Maybe their answers would have changed the conclusions you came to. You have no way of knowing until you design a better experiment so that no one is excluded.

2. The important principle here is that your sample (the people you ask the question of) must reflect very accurately the general population you want to know about. There are many ways that one can ensure that the sample one chooses is representative. For example, if your school has 1 200 learners and you would like to know how many of them like listening to kwaito, then you could ask 30 and multiply the answer by 40 to get an idea. But it would be no good if all 30 were the same age, or the same race group, or the same sex. A better plan would be to ask the school secretary to help by showing you a list of the learners in alphabetic order. You then pick every fortieth name and write it down. This will give you 30 names. You ask them and then multiply by 40.

3 What are you asking? If you go from house to house asking people whether they have brushed their teeth that morning, you'll no doubt find that most people do! By now most people know that it is socially desirable to use toothbrush and toothpaste, so they wouldn't want you to think they are ignorant – and they'll say yes, they did.

Statisticians often encounter people who lie, or who are economical with the truth. Of course, people don't actually have to lie to make the information worthless. If you send a letter to all the people you can reach who graduated from your school 10 years ago, asking them to let you know what their current salary is, you might get back only a quarter as many answers as you asked for. But, if you work out the average of

the ones who replied, wouldn't that be good enough? Let's have a look. The school did not have everybody's current address, so you could not trace everybody. Is the school more likely to have the addresses of the ones who became well-known with a steady job and a constant home, or the others who floated around doing odd jobs? And the people who threw away your letter – maybe they had nothing to brag about; the people who replied were probably proud to have others know what they earn. Maybe some even lied! It turns out that the average obtained under these circumstances could be totally unreliable.

4 Statisticians often experience trouble with central values.

As you know, the three central values are median, mode and mean. Say you are looking for a job, and you investigate the salaries of two possible employers. Below is a table showing the actual salaries for ten employees each in the two companies. You are told that the average salary is R14 000. Does that mean that it doesn't matter which

you work for? No, because you don't know what they mean by "average" – is it the mean, mode or median? As it turns out, R14 000 is the mean, but the medians are R14 000 and R5 500 respectively. Do you now know what to do? Remember that the median says that half of the people fall below that figure and half above.

A	10 000	10 000	12 000	12 000	14 000	14 000	16 000	16 000	18 000	18 000
B	1 000	2 000	3 000	4 000	5 000	6 000	7 000	8 000	9 000	95 000

Table 3.41

The lesson is to make sure that you don't make a judgement on one average only, especially if you don't know which average is meant.

5 Graphs can easily fool.

Here are three graphs – let's look at the first one.

This graph shows how a certain company's exports increased from about R16 million to nearly R19 million in a year's time – the months are shown on the x-axis and the amount in millions on the y-axis

The graph tells no lies – the y-axis starts at 0, and the line shows that there has been a small steady increase in the value of exports.

It is easy to read and understand.

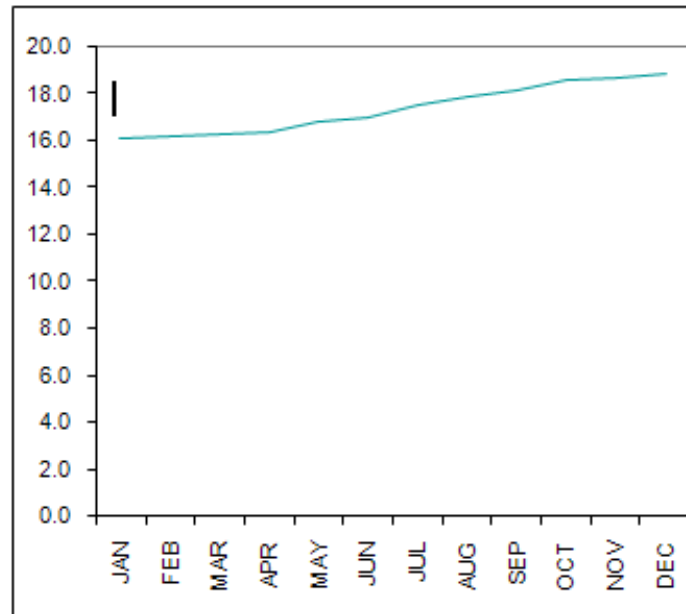

Figure 3.42

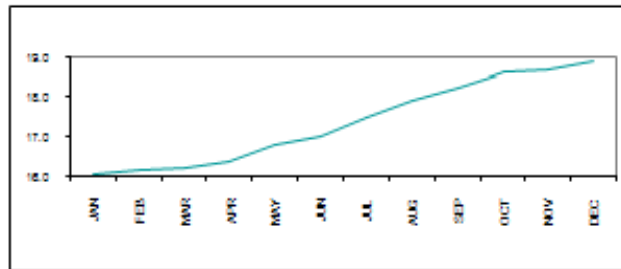

Figure 3.43

But the Board of Directors of the company are not satisfied. They would like people to invest money in the company. To encourage them, the directors decide to get rid of all that unsightly white below and above the line by changing what the y-axis shows.

This graph still does not lie – but it fools the eye into seeing a dramatic increase in exports – starting from what looks like almost nothing.

But, by doing a bit of stretching, this same graph can be given a make-over that will appeal more to possible investors.

And here is the last version – much more impressive than number one!

See how steep the growth is – it looks as if the company is growing fiercely!

It is important to check that all the values you need to understand a graph are present. Sometimes the axes are unlabelled, which makes a graph worthless for putting across accurate information. Don't place any faith in graphs which don't tell the whole story – someone may be trying to pull the wool over your eyes.

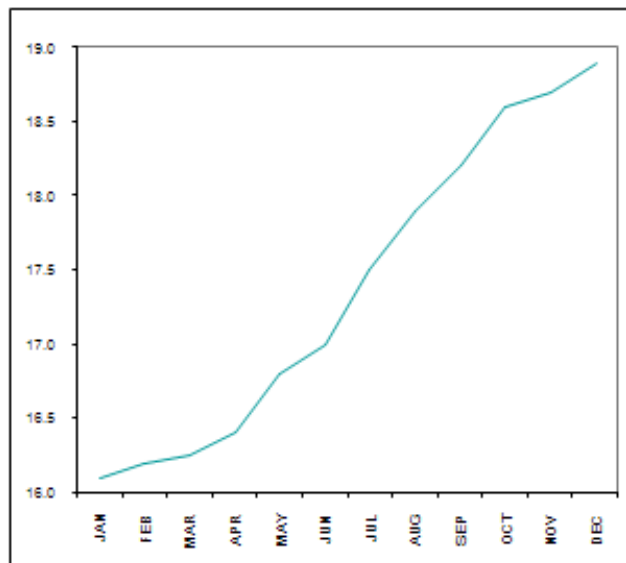

Figure 3.44

Exercise.

6 Study all the graphs of all kinds you can find, and see whether all of them tell a true and reliable story. If you find any that are doubtfully accurate, bring them to class and discuss them with your teacher and the rest of the learners. A collection of poor graphs on the maths notice board will be useful to remind us not to be gullible.

7 Evaluate the following statements to see whether the speaker could be trying to mislead you. You can assume that the figures appearing in them are correct. Write down whether you need more information to be able to say what is the truth. Also try to find out what logical errors are made in the statements.

7.1 New Spediclene kills 85% of bacteria.

7.2 As nearly half of all car accidents happen over weekends, this means that people who drive during the weekend are poorer drivers than the rest.

7.3 Last year more people died in aircraft accidents than ten years ago. Therefore flying is becoming more dangerous.

7.4 A certain travel brochure states that a certain place is suitable for people who don't like it too warm, as "the average temperature is 22 °C".



Figure 3.45

8 Finally, here is a famous graph. It does not resemble our graphs; in fact it is much more of a map or a picture. But graphs are really only special types of pictures.

Dr John Snow was a doctor in Central London, England in the 1850's. There was an outbreak of cholera (a very serious disease, often carried in contaminated water). He used a map of the area and on it he marked the public water pumps with crosses, and the home of every case of cholera with a dot. He noticed that the cholera cases lay closest to the Broad Street water pump. He had the handle of the pump removed and ended the epidemic during which more than 500 people had died. On the map you will see the cross for that water pump next to the word Broad.

If this section has opened your eyes to the value of graphs, you will appreciate a beautiful book written by Edward R. Tufte, called *The Visual Display of Quantitative Information*. You will probably have to ask a very sympathetic librarian or a university library to find out about it.

Sources:

Mathematics Teacher, December 1987

How to Lie with Statistics, Darrell Huff, Penguin Books, 1976

Getal en Ruimte, 5/6 V-A1, J H Dijkhuis et al. Educaboek (Holland), 1985

Assessment

LO 5
Data HandlingThe learner will be able to collect, summarise, display and critically analyse data in order to draw conclusions and make predictions and to interpret and determine chance variation.
We know this when the learner:
5.1 poses questions relating to human rights, social, economic, environmental and political issues in South Africa;
5.2 selects, justifies and uses appropriate methods for collecting data (alone and/or as a member of a group or team) which include questionnaires and interviews, experiments, and sources such as books, magazines and the Internet in order to answer questions and thereby draw conclusions and make predictions about the environment;
5.3 organises numerical data in different ways in order to summarise by determining:
5.3.1 measures of central tendency;
5.3.2 measures of dispersion;
<i>continued on next page</i>

5.4 draws a variety of graphs by hand/technology to display and interpret data including:
5.4.1 bar graphs and double bar graphs;

Table 3.42

3.9 Understanding the context and vocabulary of probability⁹

3.9.1 MATHEMATICS

3.9.2 Grade 9

3.9.3 NUMBER PATTERNS

3.9.4 GRAPHICAL REPRESENTATIONS

3.9.5 EQUATIONS STATISTICS

3.9.6 PROBABILITY THEORY

3.9.7 Module 20

3.9.8 UNDERSTANDING THE CONTEXT AND VOCABULARY OF PROBABILITY

What is gambling all about?

ACTIVITY 1

To understand the context and vocabulary of probability

[LO 11.2, 5.1, 5.6]

1 The following very ordinary statements all deal with probability – but they are not all perfectly accurate. With your partner, study them and decide what is left unsaid, or what information you need to be able to evaluate them. Write down the results of your discussion.

For example: “The sun will come up tomorrow morning” really means: “If I go by the fact that the sun has come up every morning of my life, I am very certain that it will happen again tomorrow morning.”

- 1.1 If I toss a coin, there is a 50:50 chance that it will land tails up.
- 1.2 Kevin is certain to phone me tonight.
- 1.3 It is virtually impossible to win the lottery.
- 1.4 If you have a positive HIV test, then you will die of AIDS.
- 1.5 You are more likely to die of a spider-bite than of a lightning strike.
- 1.6 If you are told that every raffle ticket has two numbers, you have a double chance to win.
- 1.7 If you don't play the Lotto, you are certain not to win.
- 1.8 In a room of 24 people, you are likely to find two people with the same birthday.
- 1.9 There is a 25% chance of rain tomorrow.
- 1.10 You are as likely to get a three as a four when you throw a die.

- Check the quality of your answers:

2 Refer to the following scale

⁹This content is available online at <<http://cnx.org/content/m31288/1.1/>>.

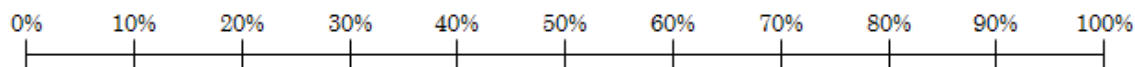

Figure 3.46

- The likelihood of something happening must lie somewhere along this line of probabilities. Nothing can be less likely than 0%, and nothing can be more likely than 100%. If you throw an ordinary six-sided die, then it is *certain* (meaning 100% on the above scale) that the number it shows will be either 1, 2, 3, 4, 5 or 6. It is *impossible* (0%) that it will show a 7. We can't always be sure exactly where a certain probability lies, but in some cases the probability can be worked out exactly.
- Write down at which percentage of the scale above each of the following statements falls; afterwards discuss your answers with your partner.

2.1 I will throw a six with an ordinary die.

2.2 If you pick a Smartie with your eyes closed, it will be a red one.

2.3 I will visit a friend next weekend.

2.4 The numbers 1, 2, 3, 4, 5 and 6 are equally likely from throwing a die.

2.5 I will meet the president of South Africa someday.

2.6 I will stay the same height for the next year.

2.7 I will get a cold next winter.

2.8 I will be the president of South Africa someday.

- How was the quality of my work now?
- Here is the same scale with other values:

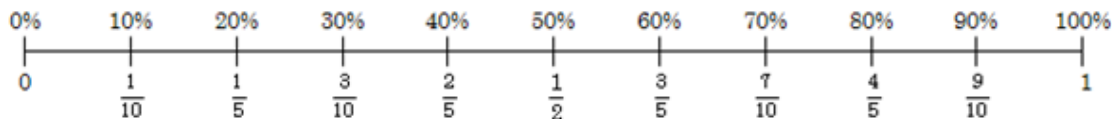

Figure 3.47

- These same probabilities are often written as a simplified fraction. Note that the line goes from 0 (impossible) to 1 (certain). We can't have probabilities that are greater than 1 – nothing can be more likely than absolutely certain! In other words, these probabilities can't be fractions with a larger numerator than denominator.

- Let's look at the die again to make it clear how it works. The dice can show one of six numbers, but the chance that it will be a six is only one out of six chances. Look at it this way: if six friends throw one dice, and each chooses a different number from 1 to 6, then it is certain that one will be right! So, each of them has only 1 of the 6 chances to be right. The fraction (the probability) is $\frac{1}{6}$, which lies between 10% and 20% on the scale.
- We call the throwing of a dice (or a similar activity) an *experiment*. The result when you throw the dice is called an *outcome*. If you are looking for, say, a three and you get a three, then this is called a *successful outcome*. With an ordinary dice, there are six *possible outcomes*. Now we can define the probability of something happening as:

$$P = \frac{\text{number of successful outcomes}}{\text{number of possible outcomes}}$$

ACTIVITY 2

To calculate probabilities in certain defined contexts

[LO 1.2, 1.4, 1.7, 5.4, 5.6]

Simple experiments

1 There are 12 balls in a bag: 3 blue balls, 5 green balls, 3 white balls and a red ball.

- If you take one out without looking, then the chance that it will be green is $\frac{5}{12}$ [U+FOB8] 12.
- It is correct to write this probability as: $P = \frac{5}{12}$; but it can also be written as a decimal fraction: $P = 0,417$. (Decimal fractions are often used as they make it easier to compare probabilities.)
- The probability of taking out a white ball is 0,25. What is the probability of taking out a ball that is either blue or white? $P = \frac{3+3}{12} = \frac{6}{12} = \frac{1}{2} = 0,5$.

1.1 Calculate the probability of taking out a ball that is either green or blue.

1.2 What is the probability of taking out a yellow ball?

2 You throw an ordinary die. Calculate the probability of your throwing:

2.1 a two

2.2 an odd number

2.3 a number bigger than two.

Compound experiments.

3 Consider a coin that is tossed: it can land with either heads or tails up.

- The possibility of getting heads is exactly the same as getting tails, namely 0,5.
- But, if you toss a coin once and then once more, how likely is it that you will get two tails in a row?

First we have to find out what the total number of outcomes can possibly be. We could get (a) heads followed by heads, or (b) heads followed by tails; or we could get (c) tails followed by tails, or (d) tails followed by heads.

The total number of outcomes is four. Getting two tails in a row happens only once of the four outcomes. Therefore its probability is $\frac{1}{4}$ or 0,25.

A question for you:

3.1 How likely is it that you will toss two *different* sides of the coin in a row?

4 Take the bag of balls as another example:

- This time it has four balls – 1 each of red (R), green (G), blue (B) and yellow (Y).
- You draw a ball out, make a note of its colour and then put it back and draw again.
- An example: You draw red followed by yellow. This can be written as RY.
- If you do this, what is the likelihood that you will draw a blue ball both times?

- First determine the total number of outcomes:
- RR ; RG ; RB ; RY if the first ball was red.
- GR ; GG ; GB ; GY if the first ball was green.
- BR ; BG ; BB ; BY if the first ball was blue.
- YR ; YG ; YB ; YY if the first ball was yellow.

4.1 Draw the tree diagram for this problem.

- This shows that the total number of outcomes is $16!$ Of these outcomes, only one is BB, so our probability is $\frac{1}{16} = 0,063$. Calculate the probability that you will get

4.2 two balls of the same colour.

4.3 two balls of different colours.

4.4 at least one yellow ball.

4.5 a blue ball on the second draw.

4.6 a white ball.

4.7 no red balls.

ACTIVITY 3

To realise that knowledge about probabilities is vital for life decisions

[LO 5.1, 5.5]

RISKS

In life we often take certain risks – in fact, life is full of risks. We can't avoid taking risks, but if we know how big the risks are, then we can avoid the bad ones. The study of risks is very difficult, but we can make some simple, wise choices if we understand the basics.

Let's look at some risks everyone is exposed to. This is only a small number of many, many daily risks.

1. Radiation can cause cancer. If all the little bits of radiation you are exposed to from day to day add up to enough, you have a greater *risk* of getting cancer. Where does radiation come from?

- There is natural radiation – it is all around us – from space and from the earth. Where you live makes a big difference. Radon is a radioactive gas that seeps out of rocks and gets trapped in houses. If you want to know how big your exposure is, then the radon in your house can be tested. Making sure that stale air in a house gets removed, is a good way to get rid of radon, even if you don't know how much there was
- Weapons are another source of radiation – think of the atom bombs dropped on Japan at the end of the Second World War. Many people died then from the explosion itself, and many died from the radiation a little later – but even now people who were exposed to the radiation are getting cancer
- Accidents at nuclear power stations usually cause some radiation to be emitted. People who come into contact with radiation in such an accident, are at risk of dying or getting cancer later.
- Ordinary medical x-rays do not add a great deal to the radiation you are exposed to. But it is sensible not to have x-rays for little reason, or too often. Just after x-rays were discovered, they were a great novelty and x-rays were taken just for the fun of it, or for trivial reasons. Now we are horrified at the thought that people could have been so careless – but they did not know any better.

2 Travel is a great source of risk. Accidents can, and do, happen frequently. But the risk varies greatly with the type of transport you choose. Passenger aircraft are very safe, while personal motorcars are much more risky. The way these risks are usually calculated is to divide the number of people dying in a certain period by the total number of kilometres each person travelled, times the total number of people travelling. This ratio is called deaths per person-kilometre. This number is higher for passenger cars than for passenger aircraft, that is why we say that travelling by air is safer than travelling by car.

- Many people believe that air travel is very dangerous. One of the reasons for this is that an aircraft accident can cause many deaths, but normally a car accident claims few lives. But one has to remember that there are few air accidents, but people die in car crashes daily. This is why the deaths per person-kilometre is a good way to compare them. By the way, bikers on motorbikes even more unsafe than motorists.
- If you want to have your car insured, then the insurance company takes these figures very seriously. They also know that people in certain age groups are more at risk, and that is why they have higher premiums for young males than for old ladies.

3 We also run a daily risk of getting sick. That is why it is sensible to protect our bodies and be aware of the ways to avoid being exposed to disease germs. For instance, people who touch their faces or food without making sure that their hands are clean after touching things like door handles, etc. that sick people may have been in contact with, are at greater risk of getting ailments like colds and flu.

4 People who often breathe in the second-hand cigarette smoke of others, run a significant risk of getting lung cancer or other lung diseases, especially if they are also often exposed to other polluted air.

- You will certainly be able to add to this list of risks. In small groups, list as many other significant risks that your environment exposes you to.

UNCERTAINTY

When a patient is tested for a disease, the *tests* may be unreliable. This means that if, for example, the test is negative then there might still be a chance that you *have* the disease, and if the test is positive, there might be a chance that they *don't* have the disease.

This is the reason why, for many serious diseases, a test is repeated after a while to see whether the result stays the same.

GAMBLING ODDS

We have seen that if you throw a die you have 1 chance in 6 of choosing the correct number. If you throw two dice (a black one and a red one) and guess a number between 2 and 12, how likely are you to be correct?

If you guessed 12, then there is only 1 chance in 36 ($P = 0,028$) to be right. But if you said 3, then you have 2 chances out of 36 ($P = 0,56$) of getting it right, namely a 1 on the black die and a 2 on the red die OR the other way round. If you wisely guess 7, then you have 6 chances out of 36 ($P = 0,167$).

In the Lotto, it has been calculated that you have 1 chance in nearly 14 million of getting all six numbers correct if you guess once. This is a very low chance! On the other hand, it can be fun thinking what you would do with your winnings, if you won.

Source:

Pythagoras, Number 52, August 2000

3.9.9 Assessment

Learning outcomes(LOs)
<i>continued on next page</i>

LO 1
Numbers, Operations and RelationshipsThe learner will be able to recognise, describe and represent numbers and their relationships, and to count, estimate, calculate and check with competence and confidence in solving problems
Assessment standards(ASs)
We know this when the learner:
1.2 recognises, uses and represents rational numbers (including very small numbers written in scientific notation), moving flexibly between equivalent forms in appropriate contexts;
1.3 solves problems in context including contexts that may be used to build awareness of other learning areas, as well as human rights, social, economic and environmental issues such as:
1.3.1 financial (including profit and loss, budgets, accounts, loans, simple and compound interest, hire purchase, exchange rates, commission, rental and banking);
1.3.2 measurements in Natural Sciences and Technology contexts;
1.4 solves problems that involve ratio, rate and proportion (direct and indirect);
1.7 recognises, describes and uses the properties of rational numbers.

Table 3.43

LO 5
Data HandlingThe learner will be able to collect, summarise, display and critically analyse data in order to draw conclusions and make predictions and to interpret and determine chance variation.
We know this when the learner:
5.1 poses questions relating to human rights, social, economic, environmental and political issues in South Africa;
5.2 selects, justifies and uses appropriate methods for collecting data (alone and/or as a member of a group or team) which include questionnaires and interviews, experiments, and sources such as books, magazines and the Internet in order to answer questions and thereby draw conclusions and make predictions about the environment;
5.3 organises numerical data in different ways in order to summarise by determining:
5.3.1 measures of central tendency;
5.3.2 measures of dispersion;
5.4 draws a variety of graphs by hand/technology to display and interpret data including:
<i>continued on next page</i>

5.4.1 bar graphs and double bar graphs;
5.4.2 histograms with given and own intervals;
5.4.3 pie charts;
5.4.4 line and broken-line graphs;
5.4.5 scatter plots;
5.5 critically reads and interprets data with awareness of sources of error and manipulation to draw conclusions and make predictions about:
5.5.1 social, environmental and political issues (e.g. crime, national expenditure, conservation, HIV/AIDS);
5.5.2 characteristics of target groups (e.g. age, gender, race, socio-economic groups);
5.5.3 attitudes or opinions of people on issues (e.g. smoking, tourism, sport);
5.5.4 any other human rights and inclusivity issues;
5.6 considers situations with equally probable outcomes, and:
5.6.1 determines probabilities for compound events using two-way tables and tree diagrams;
5.6.2 determines the probabilities for outcomes of events and predicts their relative frequency in simple experiments;
5.6.3 discusses the differences between the probability of outcomes and their relative frequency.

Table 3.44

3.9.10 Memorandum

Discussion

- The learner's module is very complete, with many examples.
- The teacher can spend time doing actual experiments (tossing a coin or throwing dice or drawing cards from a deck) and allowing the learners to practise their tallying skills for a frequency table.
- One gets dice with four faces, eight faces, and even more. These make very interesting experimental material.
- It is easy to make a cloth bag to put marbles in for some of the experiments.

Probabilities

Some comments only – the learners will (with guidance) have fun with the statements.

1.4 Relevant again later on.

1.5 A statement that is very hard to judge.

1.6 Encourage learners to figure out that this can't possibly be true.

1.8 True – as most class sizes are larger than 24, this means that more than half of the classes must have at least one pair of learners with the same birthday – let learners do some research.

2.1 Only 1 in 6

2.2 They will have to find some smarties and experiment!

2.4 True (unless the die is biased – and this does happen)

There are more aspects of risk that can be discussed – feel free to explore the subject with the learners if there is time.

Test

There is no test for this unit.

- This guide has to include two A4 sheets: one squared paper and one set of axes.
- Two paper copies of each are supplied – not electronically.

3.9.11

Chapter 4

Term 4

4.1 Explore and identify the characteristics of some quadrilaterals¹

MATHEMATICS

Grade 9

QUADRILATERALS, PERSPECTIVE DRAWING, TRANSFORMATIONS

Module 21

EXPLORE AND IDENTIFY THE CHARACTERISTICS OF SOME QUADRILATERALS

ACTIVITY 1

To explore and identify the characteristics of some quadrilaterals

[LO 3.4]

In this work, you will learn more about some very important quadrilaterals. We need to know their characteristics as they occur often in the natural world, but especially in the manmade environment.

You will have to measure the lengths of lines and the sizes of angles, so you will need to have your ruler and protractor ready. For cutting out quadrilaterals you will need a pair of scissors.

First we start with the word quadrilateral. A quadrilateral is a flat shape with four straight sides, and, therefore four corners. We will study the sides (often in opposite pairs), the internal angles (also sometimes in opposite pairs), the diagonal lines and the lines of symmetry.

Look out for new words, and make sure that you understand their exact meaning before you continue.

1. Lines of symmetry

You have already encountered the quadrilateral we call a square.

The square

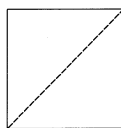

Figure 4.1

From your sheet of shapes, cut out the quadrilateral labelled “SQUARE”. Fold it carefully so that you can determine whether it has any lines of symmetry.

¹This content is available online at <<http://cnx.org/content/m31290/1.1/>>.

Lines of symmetry are lines along which any shape can be folded so that the two parts fall exactly over each other.

Make sure that you have found all the different lines of symmetry. Then mark the lines of symmetry as dotted lines on the sketch of the square alongside, using a ruler. One of them has been done as an example.

The dotted line in the sketch is also a diagonal, as it runs from one vertex (corner) to the opposite vertex.

- Look around you in the room. Can you find a square shape quickly?

If we push the square sideways, without changing its size, it turns into a rhombus.

1.2 The rhombus

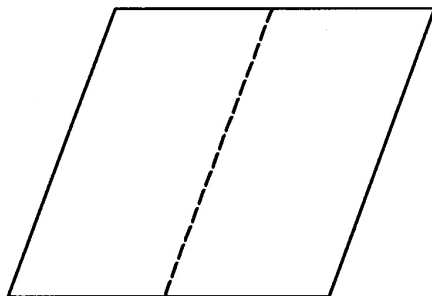

Figure 4.2

Identify the RHOMBUS from the sheet of shapes. It is clear that it looks just like a square that is leaning over. Cut it out so that you can fold it to find its lines of symmetry.

Again, draw dotted lines of symmetry on this diagram

- Is the dotted line in this sketch a line of symmetry?

If we take a rhombus and stretch it sideways, then a parallelogram is produced.

1.3 The parallelogram

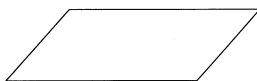

Figure 4.3

Find the PARALLELOGRAM on the sheet of shapes.

Cut it out so that you can fold it to find any lines of symmetry; draw them as dotted lines.

- You might have to search a bit to find something in the shape of a parallelogram. Your homework is to see whether you can find one in 24 hours.

This parallelogram turns into a rectangle when we push it upright.

1.4 The rectangle



Figure 4.4

Cut out the RECTANGLE and find its lines of symmetry to fill in on the rectangle alongside.

- Write down the differences you see between the rectangle and the square.

Now take the two end sides of the rectangle and turn them out in different directions to form a trapezium.

1.5 The trapezium

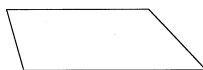

Figure 4.5

There is more than one TRAPEZIUM on the shape sheet. This is another example of a trapezium. Again, cut them out and find lines of symmetry.

- Using all the different kinds of trapezium as a guide, write down in words how you will recognise the shape.

1.6 On the shape sheet you will find two kinds of KITE. Cut out both kinds and find any lines of symmetry.

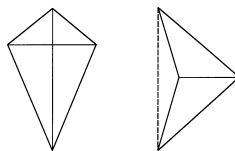

Figure 4.6

A kite is a kind of bird; it is also the name of the toy that can be made to fly in the wind, tethered by a string that is used to manipulate it. Modern kites have different ingenious shapes, but the quadrilateral gets its name from the simple paper kites, which are easy to make using two thin sticks of different lengths, some paper, glue and string – and a tail for a stabilizer.

Is there a special name for the dotted line in one of the kites above?

2. Side lengths

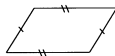

Figure 4.7

Study the examples of the six types of quadrilateral. First measure the sides of each as accurately as you can, to see whether any of the sides are the same length, and mark them. In this sketch of a parallelogram, the opposite sides have been marked with little lines to show which sides have equal lengths.

- Is a rhombus just a parallelogram with all four sides equal?

3. Parallel sides

Parallel lines (as you know) are lines that always stay equally far from each other. This means that they will never meet, no matter how far you extend them. They need not be the same length. You already know how to mark parallel lines with little arrows to show which are parallel.

Now study your quadrilaterals again to see whether you can identify the parallel lines with a bit of measuring. This is not easy, but you will do well if you concentrate and work methodically.

- If you could change just one side of any trapezium, could you turn it into a parallelogram? What would you have to change?

4. Internal angle sizes

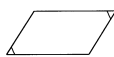

Figure 4.8

It is easy to measure the internal angles with your protractor. Write the sizes in on the sketch, and then see whether you find right angles or equal angles. You can mark equal angles with lines to show which are which, as in this sketch of the parallelogram.

- Add up all the internal angles of every quadrilateral you measured and write the answer next to the quadrilateral. Does the answer surprise you?

5. Diagonals

Diagonals run from one internal vertex to the opposite vertex. Draw the diagonals in all the quadrilaterals (sometimes they will be on top of the lines of symmetry).

Measure the lengths of the diagonals to identify those quadrilaterals where the two diagonals are the same length. Mark them if they are the same, just as you marked the equal sides.

Use your protractor to carefully measure the two angles that the diagonals make where they cross (intersect). Take note of those quadrilaterals where the diagonals cross at right angles.

The diagonals also divide the internal angles of the quadrilateral. Measure these angles and make a note of those cases where the internal angle is bisected (halved) by the diagonal.

6. Tabulate your results

Complete the following table to summarise your results for all the characteristics of all the quadrilaterals.

Think very carefully about whether what you have observed is true for all versions of the same shape. For example, you may find that the two diagonals of a certain trapezium are equal; but would they be equal for all trapeziums? And if a kite has two equal diagonals, is it correct to call it a kite?

This table contains very useful information. Make sure your table is correct, and keep it for the following exercises.

	Square	Rhombus	Parallelo-gram	Rectangle	Trapezium	Kite	
Number of lines of symmetry							
All sides equal							
2 pairs of opposite sides equal							
2 pairs of adjacent sides equal							
2 pairs of parallel sides							
Only 1 pair of parallel sides							
No parallel sides							
All internal angles equal							
2 pairs of opposite internal angles equal							

continued on next page

Only 1 pair of opposite angles equal							
Diagonals always equal							
Diagonals are perpendicular							
Both diagonals bisect internal angles							
Only one diagonal bisects internal angles							
Both diagonals bisect area							
Only one diagonal bisects area							
Diagonals bisect each other							

Table 4.1

Assessment

LO 3
Space and Shape (Geometry)The learner will be able to describe and represent characteristics and relationships between two-dimensional shapes and three-dimensional objects in a variety of orientations and positions.
<i>continued on next page</i>

We know this when the learner:
3.2 in contexts that include those that may be used to build awareness of social, cultural and environmental issues, describes the interrelationships of the properties of geometric figures and solids with justification, including:
3.2.2 transformations.
3.3 uses geometry of straight lines and triangles to solve problems and to justify relationships in geometric figures;
3.4 draws and/or constructs geometric figures and makes models of solids in order to investigate and compare their properties and model situations in the environment.

Table 4.2

4.2 Compare quadrilaterals for similarities and differences²

4.2.1 MATHEMATICS

4.2.2 Grade 9

4.2.3 QUADRILATERALS, PERSPECTIVE DRAWING, TRANSFORMATIONS

4.2.4 Module 22

4.2.5 COMPARE QUADRILATERALS FOR SIMILARITIES AND DIFFERENCES

ACTIVITY 1

To compare quadrilaterals for similarities and differences

[LO 3.4]

1. Comparisons

For the next exercise you can form small groups. You are given pairs of quadrilaterals, which you have to compare. Write down in which ways they are alike and in which ways they are different. If you can say exactly by what process you can change the one into the other, then that will show that you have really understood them. For example, look at the question on parallel sides at the end of section 3 above.

Each group should work with at least one pair of shapes. When you work with a kite, you should consider both versions of the kite.

- Rhombus and square
- Trapezium and parallelogram
- Square and rectangle
- Kite and rhombus
- Parallelogram and kite
- Rectangle and trapezium

If, in addition, you would like to compare a different pair of quadrilaterals, please do so!

1. Definitions

A very short, but accurate, description of a quadrilateral using the following characteristics, is a *definition*. This definition is unambiguous, meaning that it applies to one shape and one shape only, and we can use it to distinguish between the different types of quadrilateral.

²This content is available online at <<http://cnx.org/content/m31291/1.1/>>.

The definitions are given in a certain order because the later definitions refer to the previous definitions, to make them shorter and easier to understand. There is more than one set of definitions, and this is one of them.

- A **quadrilateral** is a plane (flat) figure bounded by four straight lines called sides.
- A **kite** is a *quadrilateral* with two pairs of equal adjacent sides.
- A **trapezium** is a *quadrilateral* with one pair of parallel opposite sides.
- A **parallelogram** is a *quadrilateral* with two pairs of parallel opposite sides.
- A **rhombus** is a *parallelogram* with equal adjacent sides.
- A **square** is a *rhombus* with four equal internal angles.
- A **rectangle** is a *parallelogram* with four equal internal angles.

ACTIVITY 2

To develop formulas for the area of quadrilaterals intuitively

[LO 3.4]

Calculating areas of plane shapes.

- Firstly, we will work with the areas of triangles. Most of you know the words “half base times height”. This is the formula for the area of a triangle, where we use **A** for the *area*, **h** for the *height* and **b** for the *base*.
- $\text{Area} = \frac{1}{2} \times \text{base} \times \text{height}$; $A = \frac{1}{2} bh$; $A =$ are various forms of the formula.
- But what is the *base*? And what is the *height*? The important point is that the height and the base make up a pair: the base is not any old side, and the height is not any old line.

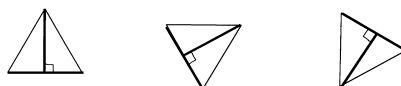

Figure 4.9

- The height is a line that is perpendicular to the side that you choose as the base. Refer to the sketches above. The base and its corresponding height are drawn as darker lines. Below are three more examples showing the base/height pairs.

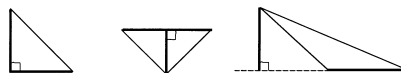

Figure 4.10

- Take two other colours, and in each of the above six triangles draw in the two other matching pairs of base/height, each pair in its own colour. Then do the following exercise:

Pick one of the triangles above, and calculate its area three times. Measure the lengths with your ruler, each time using another base/height pair. Do you find that answers agree closely? If they don't, measure more carefully and try again.

The height is often a line drawn *inside* the triangle. This is the case in four of the six triangles above. But if the triangle is right-angled, the height can be one of the *sides*. This can be seen in the fourth triangle. In the sixth triangle you can see that the height line needs to be drawn *outside* the triangle.

Summary:

In summary, if you want to use the area formula you need to have a base and a height that make a pair, and you must have (or be able to calculate) their lengths. In some of the following problems, you will have to calculate the area of a triangle on the way to an answer.

Here is a reminder of the Theorem of Pythagoras; it applies only to right-angled triangles, but you will encounter many of those from now on.

I

In a right-angled triangle, the square on the hypotenuse is equal to the sum of the squares on the other two sides.

If you are a bit vague about applying the theorem, go back to the work you did on it before and refresh your memory.

- Using the formula, calculate the area of $\triangle ABC$ where $A = 90^\circ$, $BC = 10$ cm and $AC = 8$ cm. A reasonably accurate sketch will be helpful. This is a two-step problem: first use Pythagoras and then the area formula.
- When calculating the area of quadrilaterals, the same principle applies as with triangles: when we refer to *height* it is always with reference to a specific *base*.
- We can use the formula for a triangle's area to develop some formulae for our six quadrilaterals.

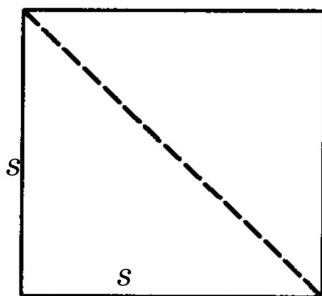

Figure 4.11

- A square consists of two identical triangles, as in the sketch. Let us call the length of the square's side s . Then the area (A) of the square is:

$$A = 2 \times \text{area of 1 triangle} = 2 \left(\frac{1}{2} \times \text{base} \times \text{height} \right) = 2 \times \frac{1}{2} \times s \times s = s^2 = \text{side squared.}$$

You probably knew this already!

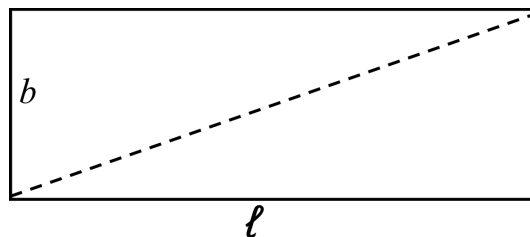

Figure 4.12

-
- It works the same for the rectangle: The rectangle is b broad and l long, and its area (A) is:

$$\begin{aligned}
 A &= \text{first triangle} + \text{second triangle} \\
 &= \left(\frac{1}{2} \times \text{base} \times \text{height}\right) + \left(\frac{1}{2} \times \text{base} \times \text{height}\right) \\
 &= \left(\frac{1}{2} \times b \times l\right) + \left(\frac{1}{2} \times l \times b\right) = \frac{1}{2} bl + \frac{1}{2} bl = bl \\
 &= \text{breadth times length.}
 \end{aligned}$$

You probably knew this already!

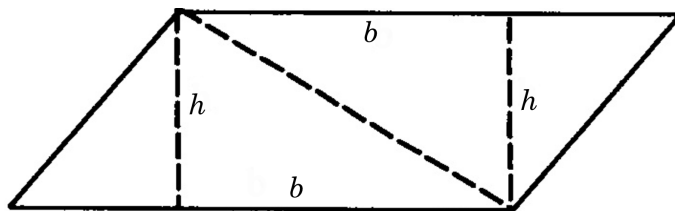

Figure 4.13

-
- The parallelogram is a little harder, but the sketch should help you understand it. If we divide it into two triangles, then we could give them the same size base (the long side of the parallelogram in each case). If we call this line the *base* of the parallelogram, we can use the letter b . You will see that the *heights* (h) of the two triangles are also drawn (remember a height must be *perpendicular* to a base).
 - Can you convince yourself (maybe by measuring) that the two heights are identical? And what about the two bases? The area is: $A = \text{triangle} + \text{triangle} = \frac{1}{2} bh + \frac{1}{2} bh = bh = \text{base times height}$.
 - A challenge for you: Do the same for the rhombus. (Answer: $A = bh$, like the parallelogram).

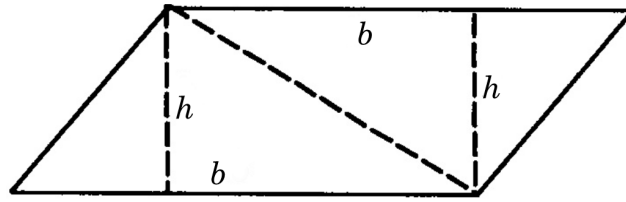

Figure 4.14

Let's see what we can do to find a formula for the trapezium. It is different from the parallelogram, as its two parallel sides are NOT the same length.

- Let us call them Ps_1 and Ps_2 . Again, the two heights are identical.
- Then from the two triangles in the sketch we can write down the area:

$$\begin{aligned}
 A &= \text{triangle}_1 + \text{triangle}_2 = \frac{1}{2} \times Ps_1 \times h + \frac{1}{2} \times Ps_2 \times h \\
 &= \frac{1}{2} h (Ps_1 + Ps_2) = \text{half height times sum of parallel sides.} \\
 &\text{(Did you notice the factorising?)}
 \end{aligned}$$

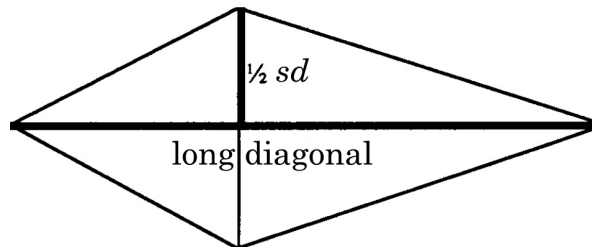

Figure 4.15

-
- Finally, we come to the kite, which has one long diagonal (which is the symmetry line) and one short diagonal, which we can call sl (symmetry line) and sd (short diagonal).
 - The kite can be divided into two identical triangles along the symmetry line. Because a kite has perpendicular diagonals, we know that we can apply the formula for the area of a triangle easily.
 - This means that the *height* of the triangles is exactly half of the short diagonal. $h = \frac{1}{2} \times sd$. Look out in the algebra below where we change h to $\frac{1}{2} sd$! Both sorts of kite work the same way, and give the same formula.
 - Refer to the sketches.

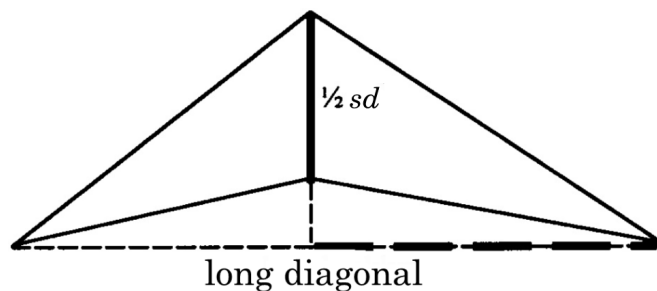

Figure 4.16

Area = 2 identical triangles

$$= 2\left(\frac{1}{2} \times sl \times h\right) = 2 \times \frac{1}{2} \times sl \times \frac{1}{2} \times sd$$

$$= sl \times \frac{1}{2} \times sd = \frac{1}{2} \times sl \times sd$$

= half long diagonal times short diagonal.

In the following exercise the questions start easy but become harder – you have to remember Pythagoras' theorem when you work with right angles.

Calculate the areas of the following quadrilaterals:

- 1 A square with side length 13 cm
- 2 A square with a diagonal of 13 cm (first use Pythagoras)
- 3 A rectangle with length 5 cm and width 6,5 cm
- 4 A rectangle with length 12 cm and diagonal 13 cm (Pythagoras)
- 5 A parallelogram with height 4 cm and base length 9 cm
- 6 A parallelogram with height 2,3 cm and base length 7,2 cm
- 7 A rhombus with sides 5 cm and height 3,5 cm
- 8 A rhombus with diagonals 11 cm and 12 cm
(What fact do you know about the diagonals of a rhombus?)
- 9 A trapezium with the two parallel sides 18 cm and 23 cm that are 7,5 cm apart
- 10 A kite with diagonals 25 cm and 17 cm

4.2.6 Assessment

LO 3
Space and Shape (Geometry) The learner will be able to describe and represent characteristics and relationships between two-dimensional shapes and three-dimensional objects in a variety of orientations and positions.
We know this when the learner:
3.2 in contexts that include those that may be used to build awareness of social, cultural and environmental issues, describes the interrelationships of the properties of geometric figures and solids with justification, including:
<i>continued on next page</i>

3.2.2 transformations.
3.3 uses geometry of straight lines and triangles to solve problems and to justify relationships in geometric figures;
3.4 draws and/or constructs geometric figures and makes models of solids in order to investigate and compare their properties and model situations in the environment.

Table 4.3

4.3 Understanding quadrilaterals and their properties in problems³

4.3.1 MATHEMATICS

4.3.2 Grade 9

4.3.3 QUADRILATERALS, PERSPECTIVE DRAWING, TRANSFORMATIONS

4.3.4 Module 23

4.3.5 UNDERSTANDING QUADRILATERALS AND THEIR PROPERTIES IN PROBLEMS

ACTIVITY 1

To apply understanding of quadrilaterals and their properties in problems
[LO 3.7, 4.4]

- All the figures for this section are on a separate problem sheet. Use it together with the questions that follow here.
- Work in pairs as follows: first study each problem independently until you have solved it or gone as far as you can. Then explain your solution carefully, and step by step, to your partner, until he understands it well enough to write it down. In the following problem it will be your partner's turn to explain his solution to you for writing down. You should remember to give a reason or explanation for everything you do.

1. Calculate the values of a , b , c , etc. from the information given here and in the sketch, and answer the question.

1.1 The diagram shows a square with one side 3 cm. a = an adjacent side.

b = the diagonal. c = the area of the square.

Why does the diagonal make a 45° angle with the side?

1.2 A rhombus is given, with long diagonal = 8 cm and short diagonal = 6 cm. a = side length.

b = area of rhombus..

Why are you allowed to use the Theorem of Pythagoras here?

1.3 The diagram shows a rectangle with a short side = 5 cm and a diagonal = 13cm.

a = the long side. b = area of rectangle.

Why is the other diagonal also 13 cm?

1.4 The figure is a parallelogram with one internal angle = 65° , height = 3 cm and long side = 9 cm.

a = smaller of internal angles. b = larger of internal angles. c = area of parallelogram

Explain why this parallelogram has the same area as a 3 cm by 9 cm rectangle.

2. Calculate the value of x from the information in the sketches.

³This content is available online at <<http://cnx.org/content/m31293/1.1/>>.

2.1 An equilateral triangle is given, with side 15 cm and area = 45 cm^2 . x = height of triangle.

Why does this triangle have a 60° internal angle?

2.2 The diagram shows a trapezium with longest side 23 cm and the side parallel to it 15 cm and height = 8 cm.

x = area of trapezium.

Why are the two marked internal angles supplementary?

2.3 The figure is a kite with area 162 cm^2 and a short diagonal of 12 cm. x = long diagonal.

Why do the internal angles of the kite add up to 360° ?

2.4 The sketch shows the kite from question 2.3 divided into 3 triangles with equal areas (ignore the dotted line). x = top part of long diagonal.

3. These problems require you to make equations from the information in the sketch, using your knowledge of the characteristics of the figure. Solving the equations gives you the value of x .

3.1 The figure is a rhombus with two angles marked $3x$ and x respectively.

Why can't we call this figure a square?

3.2 In the parallelogram, two opposite angles are marked $x + 30^\circ$ and $2x - 10^\circ$ respectively.

Explain why the marked angle is 110° .

3.3 The trapezium shows the two marked angles with sizes $x - 20^\circ$ and $x + 40^\circ$ respectively.

Why is this not a parallelogram?

3.4 Given is a rhombus with the short diagonal drawn; one angle made by the diagonal is 50° and one internal angle of the rhombus is marked x .

Shape sheet

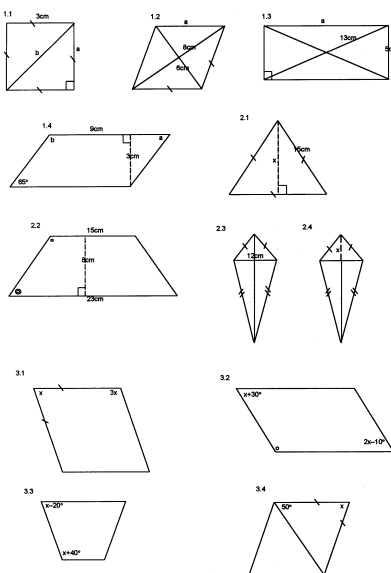

Figure 4.17

Problem sheet

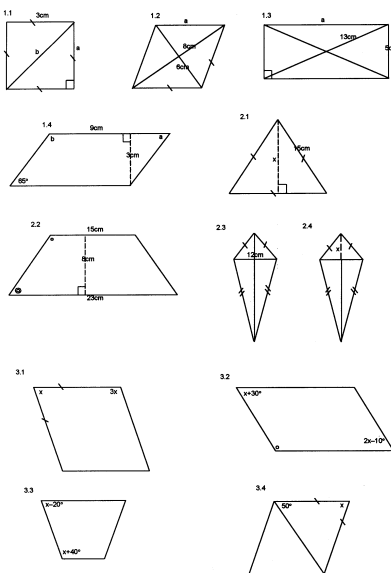

Figure 4.18

4.3.6 Assessment

LO 3
Space and Shape (Geometry)The learner will be able to describe and represent characteristics and relationships between two-dimensional shapes and three-dimensional objects in a variety of orientations and positions.
We know this when the learner:
3.2 in contexts that include those that may be used to build awareness of social, cultural and environmental issues, describes the interrelationships of the properties of geometric figures and solids with justification, including;
3.2.2 transformations.
3.3 uses geometry of straight lines and triangles to solve problems and to justify relationships in geometric figures;
3.4 draws and/or constructs geometric figures and makes models of solids in order to investigate and compare their properties and model situations in the environment;
<i>continued on next page</i>

3.6 recognises and describes geometric solids in terms of perspective, including simple perspective drawing;
3.7 uses various representational systems to describe position and movement between positions, including ordered grids
LO 4
Measurement The learner will be able to use appropriate measuring units, instruments and formulae in a variety of contexts.
We know this when the learner:
4.4 uses the theorem of Pythagoras to solve problems involving missing lengths in known geometric figures and solids.

Table 4.4

4.4 Drawing plan and side views of three-dimensional objects to scale⁴

MATHEMATICS

Grade 9

QUADRILATERALS, PERSPECTIVE DRAWING, TRANSFORMATIONS

Module 24

DRAWING PLAN AND SIDE VIEWS OF THREE-DIMENSIONAL OBJECTS TO SCALE

Putting three dimensions into two

ACTIVITY 1

To draw plan and side views of three-dimensional objects to scale

[LO 1.3, 3.4]

Orthographic projection

On the squared paper below you can see three drawings, each showing one side of a square wooden block with shaped holes in it.

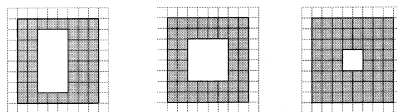

Figure 4.19

These are three orthographic views of the object. The drawings are done from the viewpoint of someone who is looking at the exact centre of each side of the block, with the line of sight perpendicular to the side. Ortho refers to 90° .

If each square on the paper represents 1 cm, calculate the outside dimensions of the block. Then calculate the total volume of wood removed in the making of the three different holes in the block.

These drawings give the dimensions of the object accurately to scale. This makes it possible for someone who has to manufacture or construct the object, to do it accurately. Architects use orthographic projections to make drawings of the plan of a building, as well as the views from the front and the sides. A builder needs

⁴This content is available online at <http://cnx.org/content/m31295/1.1/>.

to submit these drawings, as well as other technical specifications, to the people responsible for giving him permission to continue with the building.

Draw, as accurately as you can, the plan of your family's house. If you can, also draw the front view of the house. Remember that you have to decide how many metres in the actual house will be represented by each centimetre in your drawing; this is the scale of your drawing.

ACTIVITY 2

To understand what the meaning and application of perspective drawings are
[LO 3.4]

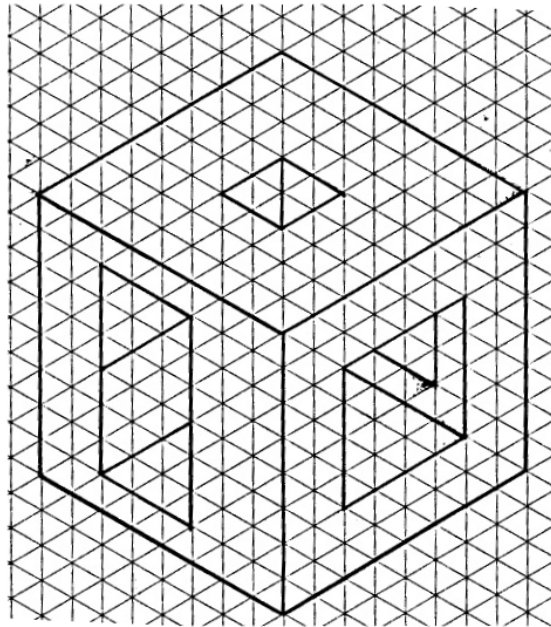

Figure 4.20

Isometric projection

Alongside is a three-dimensional drawing of the same block. You can read the dimensions of the object from the drawing, just as in the orthographic drawings above, because iso refers to the same and metric refers to measurement.

An isometric drawing is very useful, but it is not a good picture of what we would really see if we had the block in front of our eyes. To give a more realistic view of the object, we have to make a perspective drawing. This is discussed in the next section.

Here is some isometric paper for you to use.

Take one of your fat textbooks and draw an isometric projection of it. First determine a good scale for your drawing.

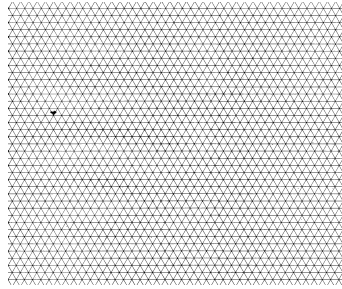

Figure 4.21

ACTIVITY 3

To understand what the meaning and application of perspective drawings are

[LO 3.6]

One-point perspective projection

This is how you can make a perspective drawing on a window (use a marker pen that will wash off the glass when you have done, or stick transparent tracing paper to the glass). On the other side of the glass you have the object you want to draw – say you put a box on a table so that you can see it clearly fitting into the whole pane of glass. Don't put the box perpendicular to the window, but put it with one corner facing forward. It is essential that you keep your head absolutely still while you work. Copy on the glass exactly what you see through the window, especially the edges of the box. You can compare your work with the explanation below, to see whether you have managed it well.

Of course, this is not what an architect does when he has to draw a picture of a building that still has to be built! He gives the orthographic projections that he has drawn to a draughtsperson who uses mathematical principles to make a perspective drawing of it.

There are one-point, two-point and three-point perspective drawings. This refers to the number of vanishing points in the drawing.

Here is a simple sketch in one-point perspective of a landscape with a railway line and a fence. There is one point on the horizon where all the lines in the sketch seem to meet and vanish.

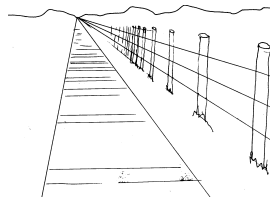

Figure 4.22

In the sketch the railway sleepers, as well as the fence posts, seem to get closer to each other as they vanish into the distance; but we know that they are evenly spaced everywhere. The railway lines seem to get closer to each other as we move our eyes to the horizon. The distances between the sleepers, and between the fence posts, diminish in proportion to how far they are away from you. These effects create the illusion of three dimensions, even though the sketch is in two dimensions on a flat sheet of paper.

The next drawing is a perspective drawing of the square block that this section started with. As you can see, this shows a more realistic view of what the block really looks like in real life. The dotted lines show the horizon and the vanishing point.

The artist and architect Filippo Brunelleschi discovered how to use one-point perspective in the beginning of the fifteenth century.

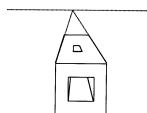

Figure 4.23

Attempt to draw a one-point perspective drawing of the block from the face of the block you can't see in this drawing.

Assessment

Learning outcomes(LOs)
LO 1
Numbers, Operations and RelationshipsThe learner will be able to recognise, describe and represent numbers and their relationships, and to count, estimate, calculate and check with competence and confidence in solving problems.
Assessment standards(ASs)
We know this when the learner:
1.3 solves problems in context including contexts that may be used to build awareness of other learning areas, as well as human rights, social, economic and environmental issues such as:
1.3.2 measurements in Natural Sciences and Technology contexts.
LO 3
Space and Shape (Geometry)The learner will be able to describe and represent characteristics and relationships between two-dimensional shapes and three-dimensional objects in a variety of orientations and positions.
<i>continued on next page</i>

We know this when the learner:
3.2 in contexts that include those that may be used to build awareness of social, cultural and environmental issues, describes the interrelationships of the properties of geometric figures and solids with justification, including:
3.2.2 transformations.
3.3 uses geometry of straight lines and triangles to solve problems and to justify relationships in geometric figures;
3.4 draws and/or constructs geometric figures and makes models of solids in order to investigate and compare their properties and model situations in the environment;
3.6 recognises and describes geometric solids in terms of perspective, including simple perspective drawing;
3.7 uses various representational systems to describe position and movement between positions, including: ordered grids

Table 4.5

4.5 Understand and use the principle of translation, learning suitable notations⁵

4.5.1 MATHEMATICS

4.5.2 Grade 9

4.5.3 QUADRILATERALS, PERSPECTIVE DRAWING, TRANSFORMATIONS

4.5.4 Module 25

4.5.5 UNDERSTAND AND USE THE PRINCIPLE OF TRANSLATION, LEARNING SUITABLE NOTATIONS

Having fun with plane shapes

ACTIVITY 1

To understand and use the principle of translation, learning suitable notations

[LO 3.2, 3.7]

Transformation through translation

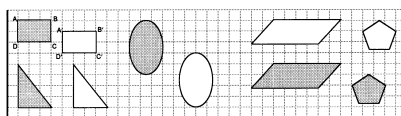

Figure 4.24

⁵This content is available online at <<http://cnx.org/content/m31296/1.1/>>.

Above we have the *first quadrant* of a *Cartesian plane*. There are ten *plane figures* to be seen.

If you imagine that you cut out the shaded shapes above, and then move them to new positions (unshaded) by *sliding* them across the page, then you have *translated* them. Notice that they stay upright (they don't change their *orientation*). These shapes have been *transformed* through translation.

- Write down the names of the five shapes.

If you label the vertices of the shape, then the new position has similar (but not the same) labels. You can see this on the rectangle above. From now on, you will use the same system of labels in your work. In the rectangle, position A moves to position A [U+FOA2], B to B [U+FOA2], etc.

We have different ways of describing translations. This is like giving someone instructions so that they can produce the result you want.

1. For instance, if I say, "Move the oval shape $4\frac{1}{2}$ units right and 3 units down," this gives the new position of the oval.

- Describe the new position of the pentagon in the same way in words.

2. Translating the square:

Square ABCD \rightarrow square A [U+FOA2] B [U+FOA2] C [U+FOA2] D [U+FOA2] means *map* square ABCD *onto* square A [U+FOA2] B [U+FOA2] C [U+FOA2] D [U+FOA2]. This is better said by specifying the positions: A (1 ; 9) \rightarrow A [U+FOA2] (5 ; 8) and B(4 ; 9) \rightarrow B [U+FOA2] (8 ; 8), etc.

- Use the coordinate mapping system to describe the translation of the triangle. Label the vertices A, B and C.

3. We can also say how far the shape must move in a certain direction, which we can specify as a *compass bearing*. This says how many degrees (navigators normally use three figures) clockwise we turn from due north. Refer to the figure. You can see that east is at 090° and west is at 270° . The line is at approximately 200° . The triangle above is 5 units away on a bearing of 090° . In other words, if you are at the top vertex of the triangle, you can see the new position of the top vertex 5 units away if you look east.

- Use distance and bearing to translate the parallelogram above.

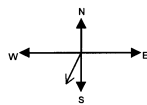

Figure 4.25

- Give the shapes below (A to E) their proper names, label their vertices, and then draw them on this grid, translated to their new positions according to the descriptions below. Finally label the "new" vertices properly. Hint: work in pencil until you are sure!

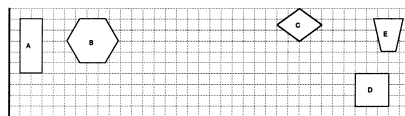

Figure 4.26

A 21 units right and 3 units down

B 11 units on a bearing of 090°

C 20 units left and 6 units down

D $(31 ; 4) \rightarrow (11 ; 6)$, $(34 ; 4) \rightarrow (14 ; 6)$, $(31 ; 1) \rightarrow (11 ; 3)$ and $(34 ; 1) \rightarrow (14 ; 3)$

E 7 units on a bearing of 270° followed by 4 units on a bearing of 180°

ACTIVITY 2

To understand and apply reflection

[LO 3.2, 3.7]

Transformation through reflection

Look again at the last problem (E) in the previous section. Can you see that it actually gives us two translations, one after the other? The descriptions for A and C do the same! This will happen again, as it is often the simplest way to describe a complicated transformation of a shape.

First plot the following points on the given Cartesian plane, connect them in order with straight lines to draw the shape, and then map the coordinates as given to transform the figures.

A(2 ; 2) , B(2 ; 4) , C(4 ; 4) , D(4 ; 6) , E(6 ; 6) , D(6 ; 2) , A(2 ; 2)

A(2 ; 2) \rightarrow A [U+F0A2] (12 ; 2) ,

B(2 ; 4) \rightarrow B [U+F0A2] (12 ; 4) ,

C(4 ; 4) \rightarrow C [U+F0A2] (10 ; 4) ,

D(4 ; 6) \rightarrow D [U+F0A2] (10 ; 6) ,

E(6 ; 6) \rightarrow E [U+F0A2] (8 ; 6) ,

D(6 ; 2) \rightarrow D [U+F0A2] (8 ; 2).

Can you see that the shape is *reflected* in the line on the grid? This means that if you were to fold the grid on the line, then the shape will fall on (coincide with) its reflection. In other words, the line of reflection is a line of symmetry for the shape and its reflection. We can also say we are *flipping* the shape, but this doesn't tell us where it ends up.

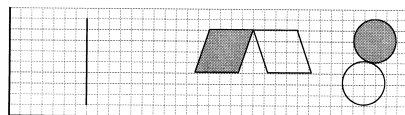

Figure 4.27

We *could* say: “Flip the shape to the right and then move it two units to the right.”

- The parallelogram has also been transformed by reflection. Draw the line of reflection.
- Draw the line of reflection for the circle.
- The circle can also be seen as having been *slid*. Describe in words how the circle was *translated*. What is it about the circle that makes it possible to see its transformation as either reflection or translation?

Choose one of the shapes above and connect each point of the shape with its corresponding reflected point. Now take the centres of these lines and draw a line through the centres. This is the line of reflection.

- Find the line of reflection in this way for all three shapes above.

On the grid below, draw the position of each shape once it has been *reflected* in the given line. Note that the line of reflection can go through the figure; it can touch the figure, or be outside it.

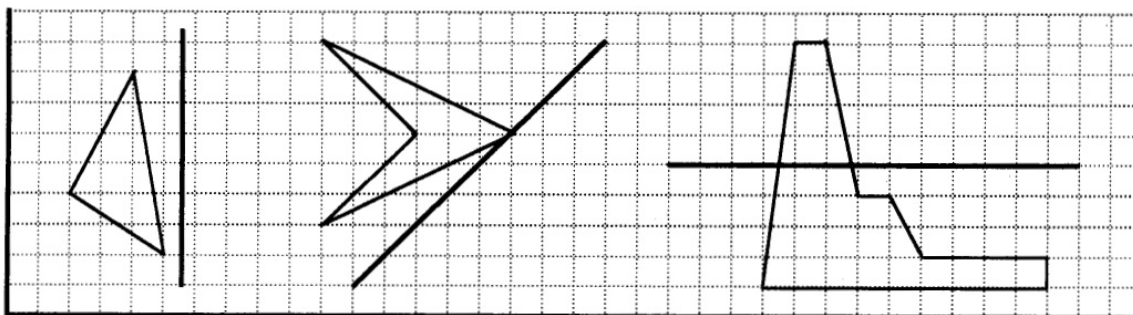

Figure 4.28

We often reflect figures in the x -axis or the y -axis.

- On the following Cartesian plane reflect each shape in the x -axis, then in the y -axis and again in the x -axis, so that you have four of them, each in a different quadrant.

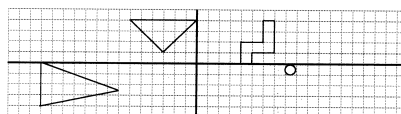

Figure 4.29

You may colour the design in.

ACTIVITY 3

To learn how to transform by rotation, and put translations together

[LO 3.2, 3.7]

Rotation

In the diagram below, there is a point marked X on each shape. Imagine that the shaded shape was cut out and loose. A pin was stuck into the point X, and the shape was turned around the pin so that it fell over the unshaded shape. To specify how far we have to turn it, we have to use *angles*. For example, the triangle was turned (*rotated*) clockwise through 90° .

- For each of the other shapes, say how many degrees, in which direction, it was *rotated*.

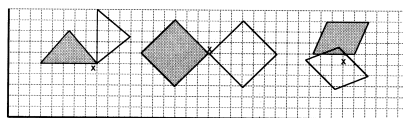

Figure 4.30

- Label the vertices of each of the three figures and describe each of the transformations in terms of coordinate mapping.
- Describe the transformation of the square as a translation (a) in terms of bearing and direction and (b) in words.
- Describe the transformation of the square as a reflection.

Below you have been given figure A. Draw figure B by reflecting figure A in the given line. Draw figure C by translating figure B 8 units right and 2 units down. Then rotate figure C 180 ° around the point marked X in figure A to give figure D. We can say that figure D is a *complex* transformation of figure A, as we needed several steps to draw it.

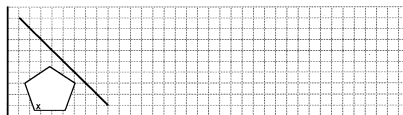

Figure 4.31

ACTIVITY 4

To enjoy transformations in the form of tilings and tessellations

[LO 3.2, 3.7]

The most remarkable and widely spread use of tessellations can be found in the decoration applied to buildings in the Islamic world. Islam forbids the making of images, so the builders concentrated on shapes. The Persians were competent mathematicians, and this helped to establish the rules of tessellation they used to such brilliant effect in the mosques and other important cultural centres. Even more interesting is the fact that the surfaces were often curved, not flat, which makes the principles of tessellation even trickier.

- When you can make tiles of a certain shape with the property that you can place them next to each other on a surface so that they don't overlap, and don't leave any gaps, then we call this a tessellation.
- You can experiment with this by cutting shapes carefully out of cardboard, and fitting them together.
- You can also do this as a drawing on paper, by combining the principles of transformation (translation, reflection and rotation) to a starting shape until you have tessellated the surface completely.
- The shapes can be simple, without any transformation except translation, or complicated with complex transformations. When you use more than one shape in a tessellation, you can produce some very beautiful designs.
- Below you can see a few tessellations. Discuss (in your group) what you see and then try to write down exactly what was done to each shape (translation, reflection and rotation), to produce the final result. Complete any incomplete ones.

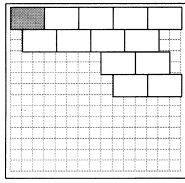

Figure 4.32

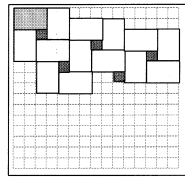

Figure 4.33

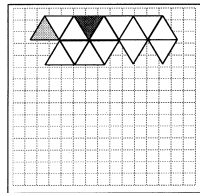

Figure 4.34

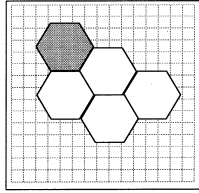

Figure 4.35

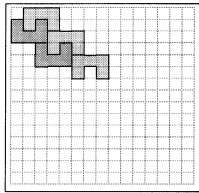

Figure 4.36

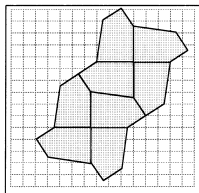

Figure 4.37

4.5.6 Assessment

LO 3

continued on next page

Space and Shape (Geometry)The learner will be able to describe and represent characteristics and relationships between two-dimensional shapes and three-dimensional objects in a variety of orientations and positions.
We know this when the learner:
3.2 in contexts that include those that may be used to build awareness of social, cultural and environmental issues, describes the interrelationships of the properties of geometric figures and solids with justification, including:
3.2.2 transformations.
3.3 uses geometry of straight lines and triangles to solve problems and to justify relationships in geometric figures;
3.4 draws and/or constructs geometric figures and makes models of solids in order to investigate and compare their properties and model situations in the environment;
3.6 recognises and describes geometric solids in terms of perspective, including simple perspective drawing;
3.7 uses various representational systems to describe position and movement between positions, including:ordered grids

Table 4.6

Attributions

Collection: *Mathematics Grade 9*

Edited by: Siyavula Uploaders

URL: <http://cnx.org/content/col11056/1.1/>

License: <http://creativecommons.org/licenses/by/3.0/>

Module: "Numbers - where do they come from?"

By: Siyavula Uploaders

URL: <http://cnx.org/content/m31203/1.1/>

Pages: 1-12

Copyright: Siyavula Uploaders

License: <http://creativecommons.org/licenses/by/3.0/>

Module: "Easier algebra with exponents"

By: Siyavula Uploaders

URL: <http://cnx.org/content/m31943/1.1/>

Pages: 12-19

Copyright: Siyavula Uploaders

License: <http://creativecommons.org/licenses/by/3.0/>

Module: "Why all the fuss about Pythagoras?"

By: Siyavula Uploaders

URL: <http://cnx.org/content/m31205/1.1/>

Pages: 19-28

Copyright: Siyavula Uploaders

License: <http://creativecommons.org/licenses/by/3.0/>

Module: "How long is a piece of string?"

By: Siyavula Uploaders

URL: <http://cnx.org/content/m31206/1.1/>

Pages: 28-33

Copyright: Siyavula Uploaders

License: <http://creativecommons.org/licenses/by/3.0/>

Module: "Money Matters"

By: Siyavula Uploaders

URL: <http://cnx.org/content/m31207/1.1/>

Pages: 34-40

Copyright: Siyavula Uploaders

License: <http://creativecommons.org/licenses/by/3.0/>

Module: "The algebra of the four basic operations"

By: Siyavula Uploaders

URL: <http://cnx.org/content/m31212/1.1/>

Pages: 41-53

Copyright: Siyavula Uploaders

License: <http://creativecommons.org/licenses/by/3.0/>

Module: "Geometry of lines and triangles"
 By: Siyavula Uploaders
 URL: <http://cnx.org/content/m31227/1.1/>
 Pages: 53-63
 Copyright: Siyavula Uploaders
 License: <http://creativecommons.org/licenses/by/3.0/>

Module: "Space and shape"
 By: Siyavula Uploaders
 URL: <http://cnx.org/content/m31220/1.1/>
 Pages: 64-72
 Copyright: Siyavula Uploaders
 License: <http://creativecommons.org/licenses/by/3.0/>

Module: "Congruency"
 By: Siyavula Uploaders
 URL: <http://cnx.org/content/m31234/1.1/>
 Pages: 72-83
 Copyright: Siyavula Uploaders
 License: <http://creativecommons.org/licenses/by/3.0/>

Module: "Similarity"
 By: Siyavula Uploaders
 URL: <http://cnx.org/content/m31235/1.1/>
 Pages: 83-91
 Copyright: Siyavula Uploaders
 License: <http://creativecommons.org/licenses/by/3.0/>

Module: "Worksheets"
 By: Siyavula Uploaders
 URL: <http://cnx.org/content/m31848/1.1/>
 Pages: 92-100
 Copyright: Siyavula Uploaders
 License: <http://creativecommons.org/licenses/by/3.0/>

Module: "Number patterns"
 By: Siyavula Uploaders
 URL: <http://cnx.org/content/m31253/1.1/>
 Pages: 101-111
 Copyright: Siyavula Uploaders
 License: <http://creativecommons.org/licenses/by/3.0/>

Module: "Understanding what graphs tell us"
 By: Siyavula Uploaders
 URL: <http://cnx.org/content/m31265/1.1/>
 Pages: 112-123
 Copyright: Siyavula Uploaders
 License: <http://creativecommons.org/licenses/by/3.0/>

Module: "Understanding how equations are represented on a graph"
 By: Siyavula Uploaders
 URL: <http://cnx.org/content/m31268/1.1/>
 Pages: 123-133
 Copyright: Siyavula Uploaders
 License: <http://creativecommons.org/licenses/by/3.0/>

Module: "Finding the equation of a straight line graph from a diagram"

By: Siyavula Uploaders

URL: <http://cnx.org/content/m31271/1.1/>

Pages: 134-139

Copyright: Siyavula Uploaders

License: <http://creativecommons.org/licenses/by/3.0/>

Module: "Solving simple problems by forming and solving equations"

By: Siyavula Uploaders

URL: <http://cnx.org/content/m31273/1.1/>

Pages: 139-147

Copyright: Siyavula Uploaders

License: <http://creativecommons.org/licenses/by/3.0/>

Module: "Collecting information to answer general questions"

By: Siyavula Uploaders

URL: <http://cnx.org/content/m31279/1.1/>

Pages: 147-153

Copyright: Siyavula Uploaders

License: <http://creativecommons.org/licenses/by/3.0/>

Module: "Analyse data for meaningful patterns and measures"

By: Siyavula Uploaders

URL: <http://cnx.org/content/m31280/1.1/>

Pages: 153-162

Copyright: Siyavula Uploaders

License: <http://creativecommons.org/licenses/by/3.0/>

Module: "Extract meaningful information from data"

By: Siyavula Uploaders

URL: <http://cnx.org/content/m31282/1.1/>

Pages: 162-173

Copyright: Siyavula Uploaders

License: <http://creativecommons.org/licenses/by/3.0/>

Module: "Understanding the context and vocabulary of probability"

By: Siyavula Uploaders

URL: <http://cnx.org/content/m31288/1.1/>

Pages: 173-180

Copyright: Siyavula Uploaders

License: <http://creativecommons.org/licenses/by/3.0/>

Module: "Explore and identify the characteristics of some quadrilaterals"

By: Siyavula Uploaders

URL: <http://cnx.org/content/m31290/1.1/>

Pages: 181-187

Copyright: Siyavula Uploaders

License: <http://creativecommons.org/licenses/by/3.0/>

Module: "Compare quadrilaterals for similarities and differences"

By: Siyavula Uploaders

URL: <http://cnx.org/content/m31291/1.1/>

Pages: 187-193

Copyright: Siyavula Uploaders

License: <http://creativecommons.org/licenses/by/3.0/>

Module: "Understanding quadrilaterals and their properties in problems"

By: Siyavula Uploaders

URL: <http://cnx.org/content/m31293/1.1/>

Pages: 193-196

Copyright: Siyavula Uploaders

License: <http://creativecommons.org/licenses/by/3.0/>

Module: "Drawing plan and side views of three-dimensional objects to scale"

By: Siyavula Uploaders

URL: <http://cnx.org/content/m31295/1.1/>

Pages: 196-200

Copyright: Siyavula Uploaders

License: <http://creativecommons.org/licenses/by/3.0/>

Module: "Understand and use the principle of translation, learning suitable notations"

By: Siyavula Uploaders

URL: <http://cnx.org/content/m31296/1.1/>

Pages: 200-207

Copyright: Siyavula Uploaders

License: <http://creativecommons.org/licenses/by/3.0/>

About Connexions

Since 1999, Connexions has been pioneering a global system where anyone can create course materials and make them fully accessible and easily reusable free of charge. We are a Web-based authoring, teaching and learning environment open to anyone interested in education, including students, teachers, professors and lifelong learners. We connect ideas and facilitate educational communities.

Connexions's modular, interactive courses are in use worldwide by universities, community colleges, K-12 schools, distance learners, and lifelong learners. Connexions materials are in many languages, including English, Spanish, Chinese, Japanese, Italian, Vietnamese, French, Portuguese, and Thai. Connexions is part of an exciting new information distribution system that allows for **Print on Demand Books**. Connexions has partnered with innovative on-demand publisher QOOP to accelerate the delivery of printed course materials and textbooks into classrooms worldwide at lower prices than traditional academic publishers.